



(19) **United States**

(12) **Patent Application Publication**
Follet et al.

(10) **Pub. No.: US 2017/0071290 A1**

(43) **Pub. Date: Mar. 16, 2017**

(54) **ARTICLE OF FOOTWEAR WITH KNITTED COMPONENT HAVING PLURALITY OF GRADUATED PROJECTIONS**

(52) **U.S. Cl.**
CPC *A43B 23/026* (2013.01); *A43B 13/125* (2013.01); *A43B 13/181* (2013.01); *A43C 15/16* (2013.01); *A43B 23/081* (2013.01); *A43B 3/0078* (2013.01); *A43C 1/04* (2013.01); *A43B 23/042* (2013.01); *A43B 23/0205* (2013.01)

(71) Applicant: **NIKE, Inc.**, Beaverton, OR (US)

(72) Inventors: **Lysandre Follet**, Portland, OR (US); **Gjermund Haugbro**, Beaverton, OR (US); **James Molyneux**, Portland, OR (US); **Phil Woodman**, Treviso (IT)

(57) **ABSTRACT**

(21) Appl. No.: **14/851,920**

(22) Filed: **Sep. 11, 2015**

Publication Classification

(51) **Int. Cl.**

- A43B 23/02* (2006.01)
- A43B 13/18* (2006.01)
- A43B 23/04* (2006.01)
- A43B 23/08* (2006.01)
- A43B 3/00* (2006.01)
- A43C 1/04* (2006.01)
- A43B 13/12* (2006.01)
- A43C 15/16* (2006.01)

An article of footwear includes a sole structure and an upper that is attached to the sole structure. The upper defines a cavity that is configured to receive a foot of a wearer. The upper is at least partially defined by a textile. The textile includes a first area that is substantially smooth. The first area defines a reference boundary that conforms to the cavity. The textile includes a second area. The second area includes a plurality of projection structures that project away from the reference boundary and outwardly from the cavity at varying heights. The second area includes a plurality of recess structures that recess away from the reference boundary and inwardly toward the cavity. The plurality of projection structures and the plurality of recess structures are in an alternating arrangement across the textile.

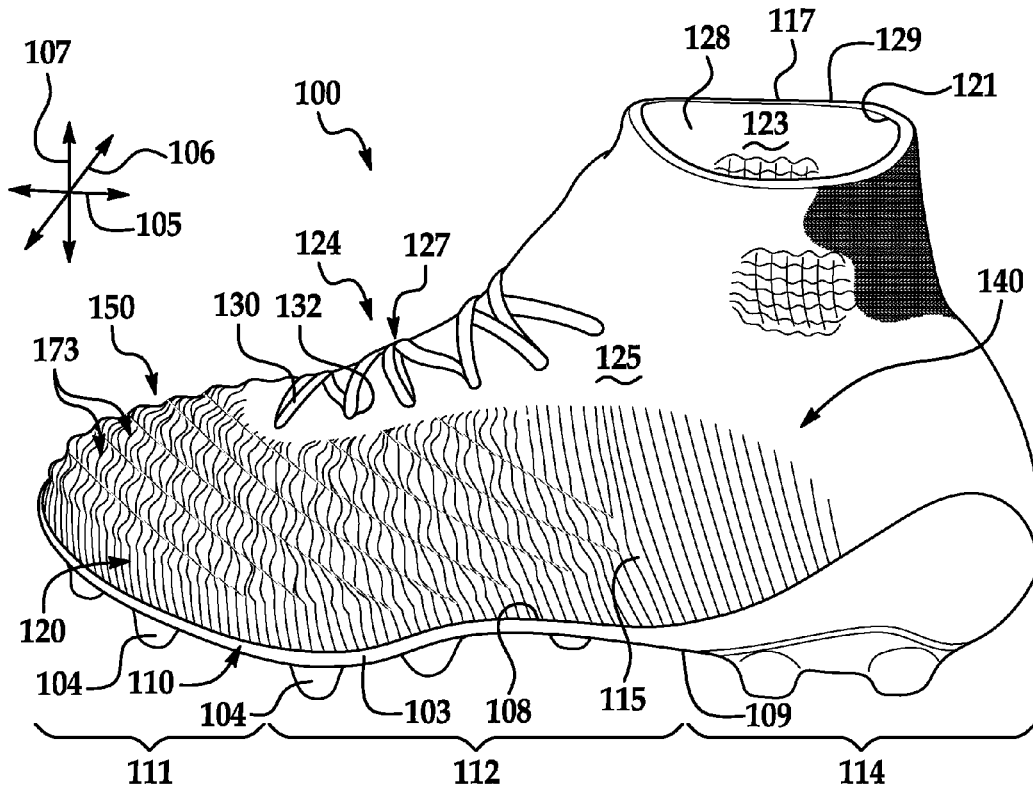

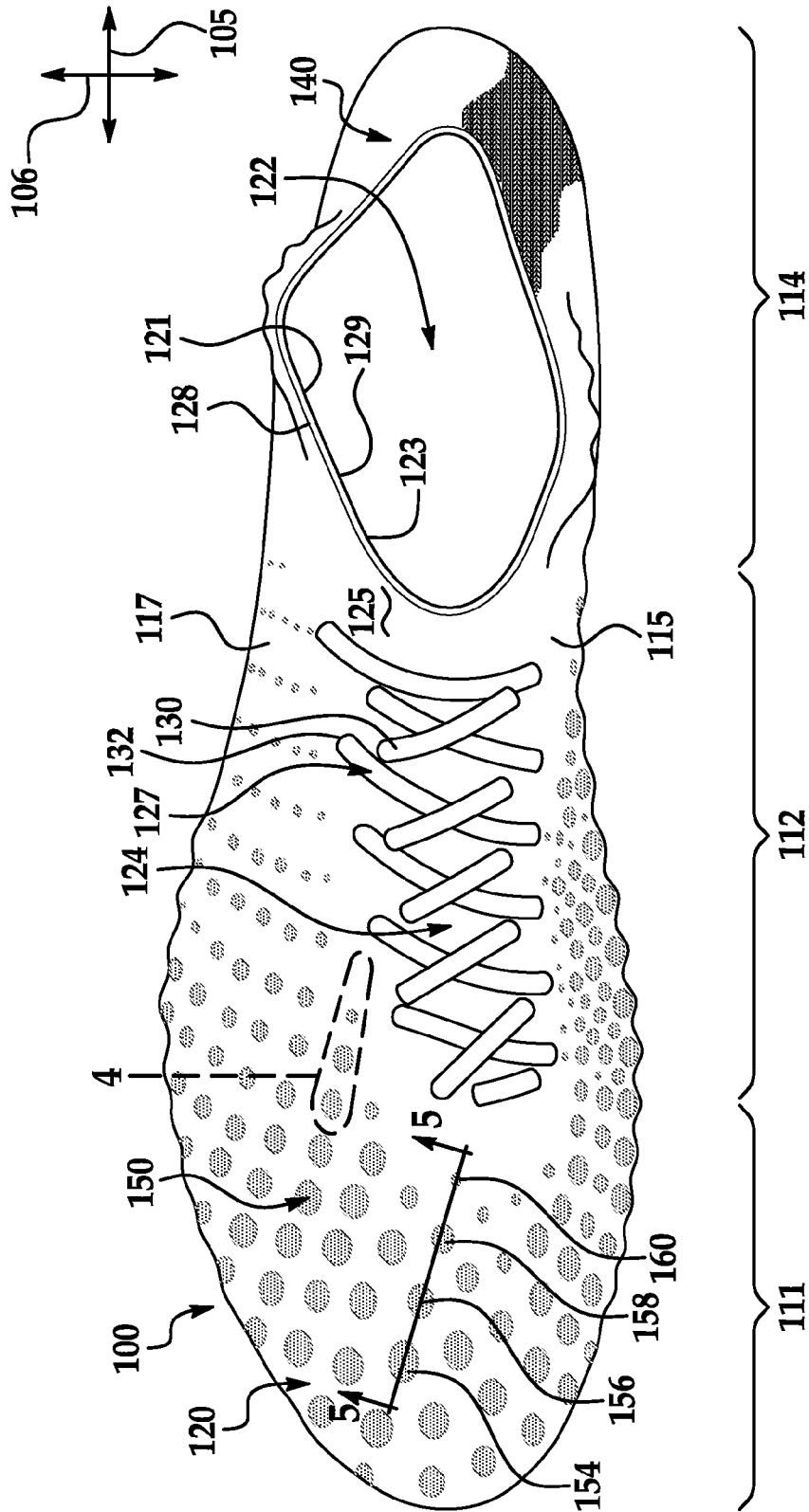

FIG. 1

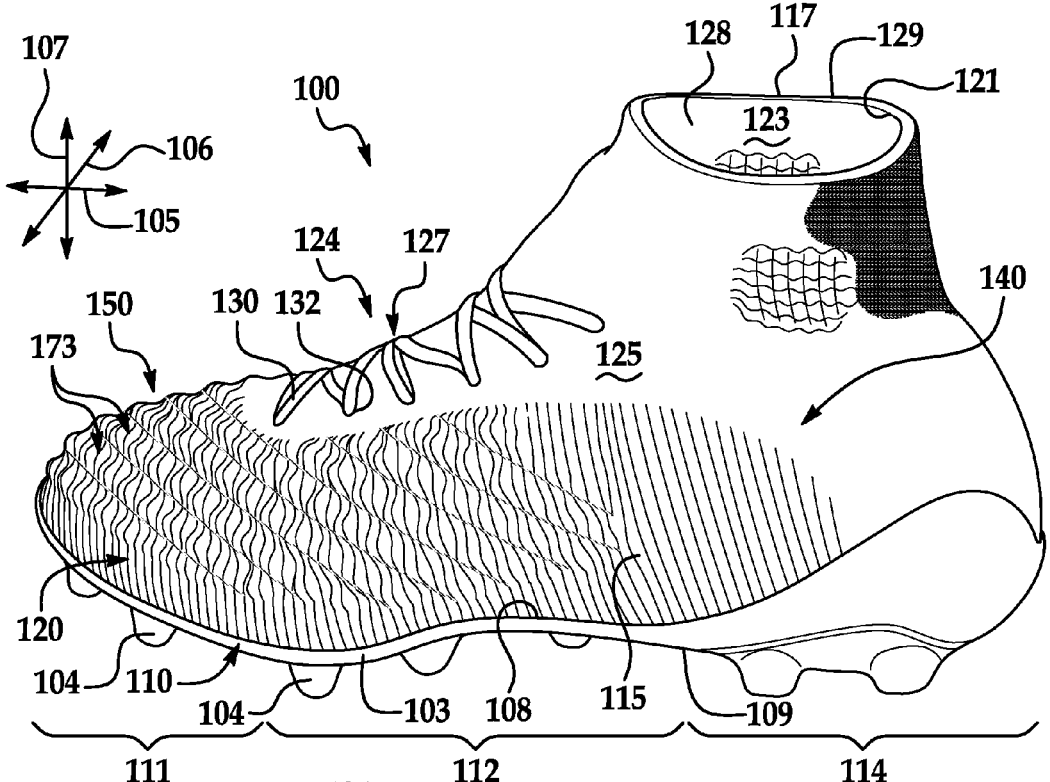

FIG. 2

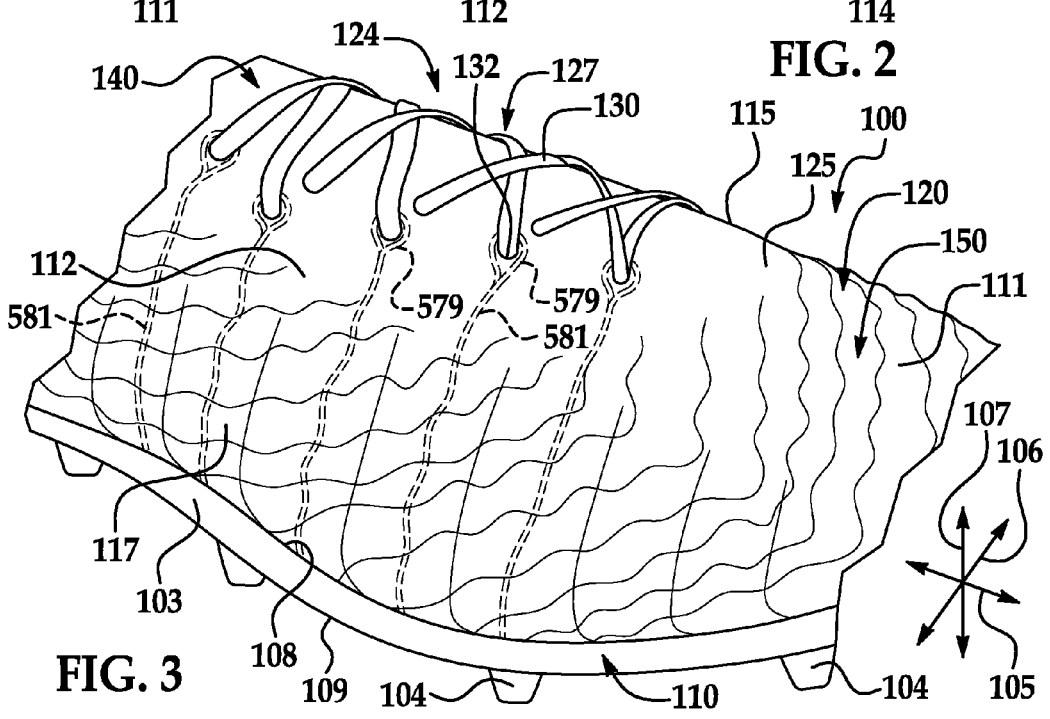

FIG. 3

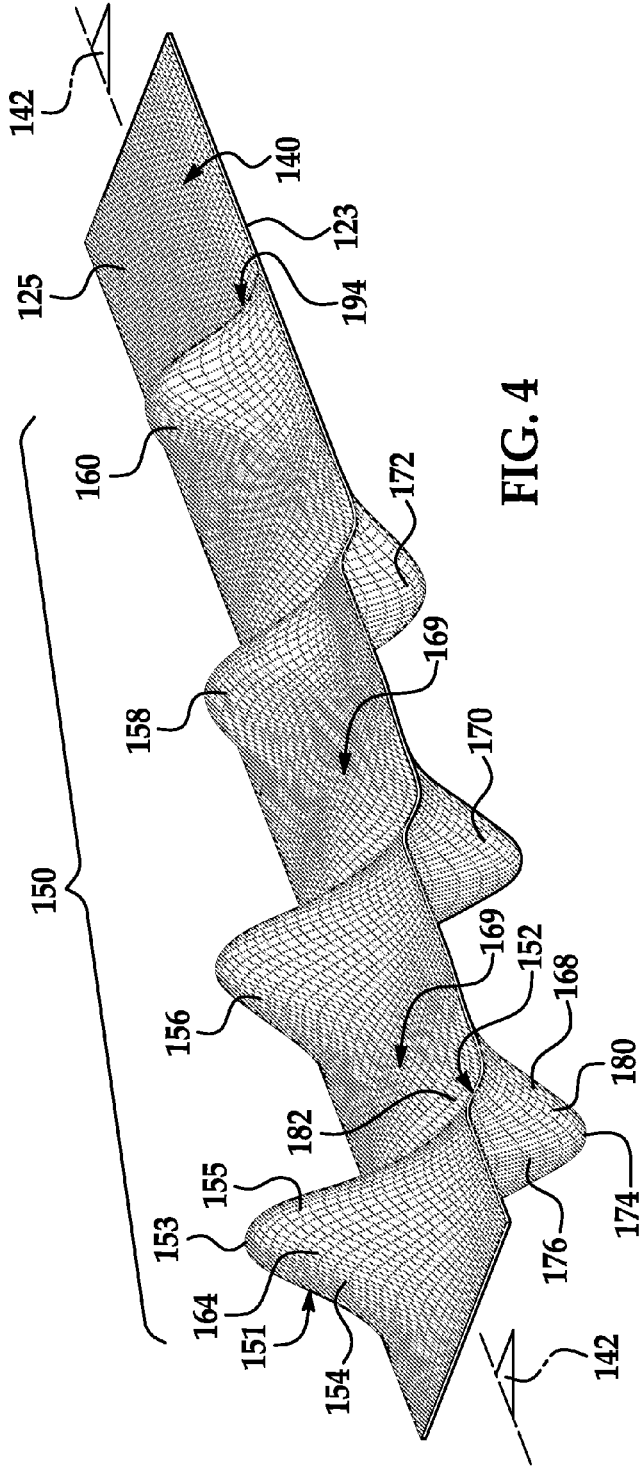

FIG. 4

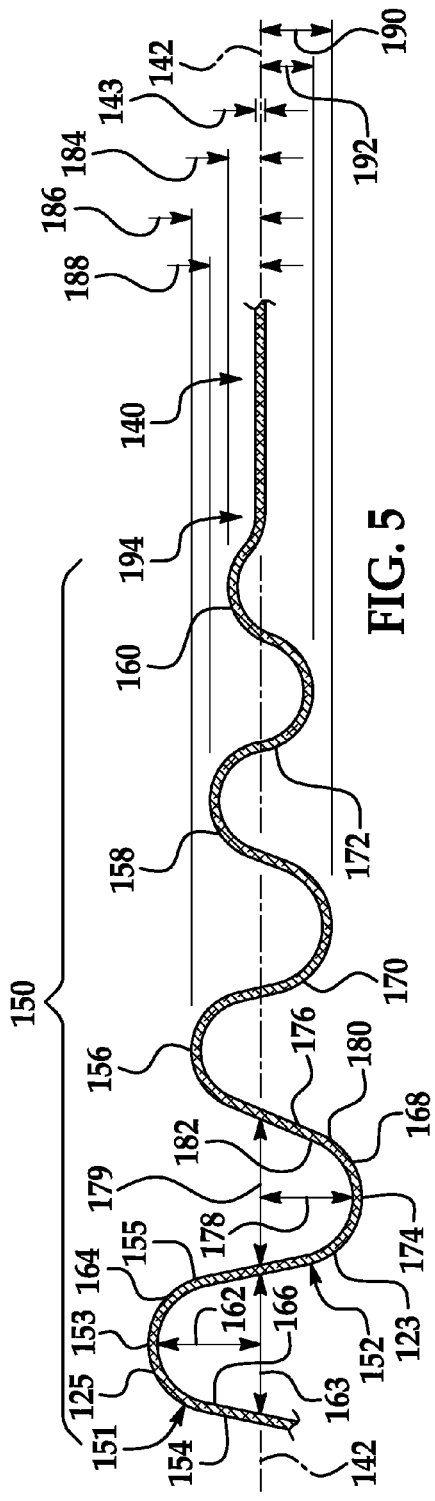

FIG. 5

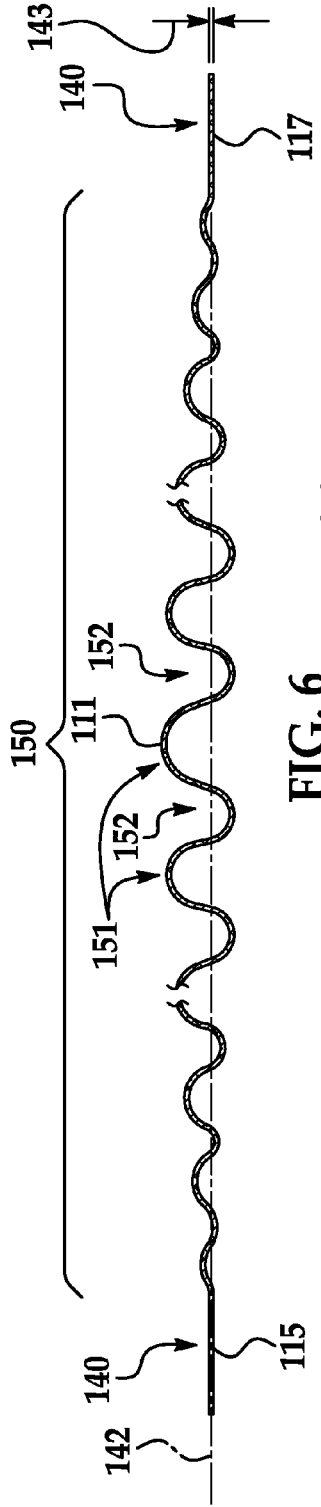

FIG. 6

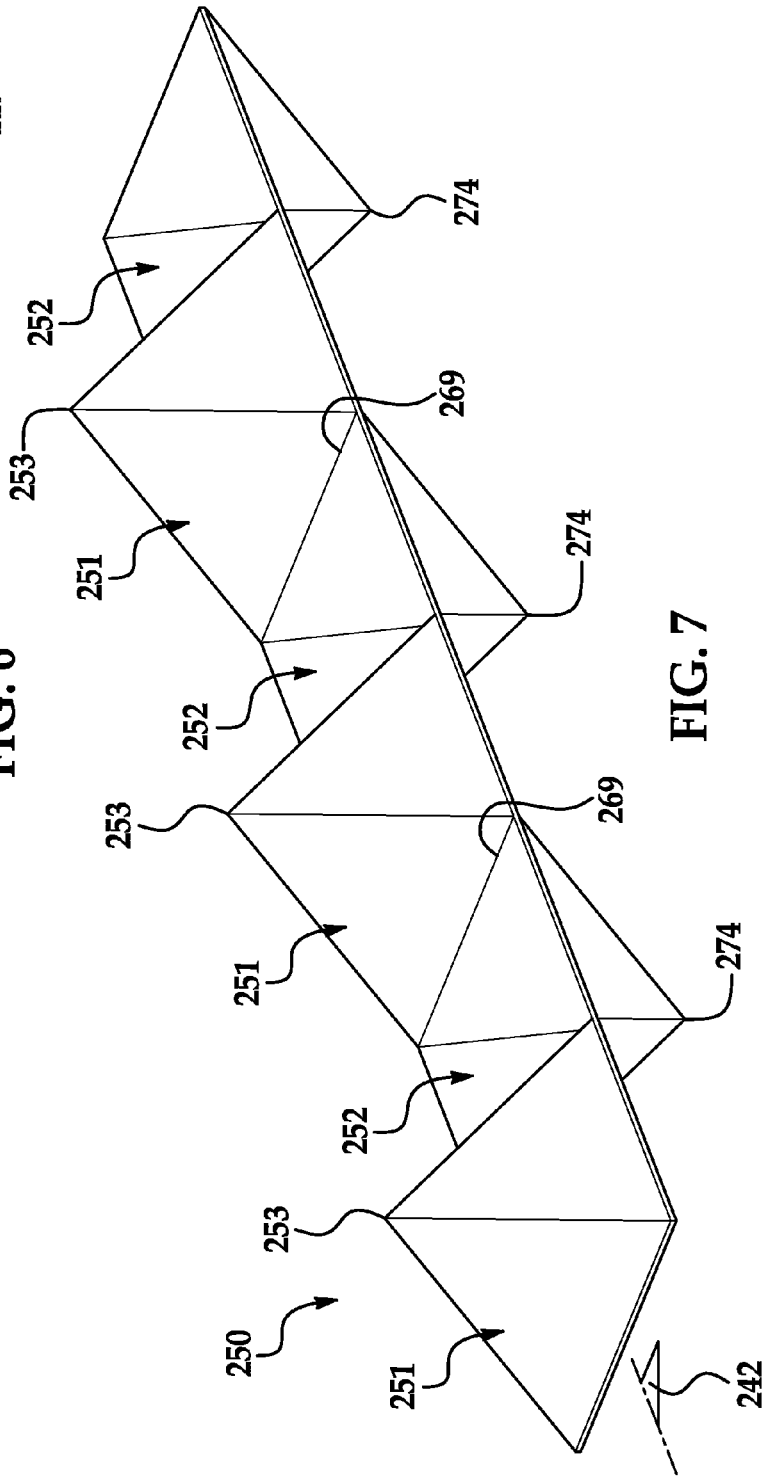

FIG. 7

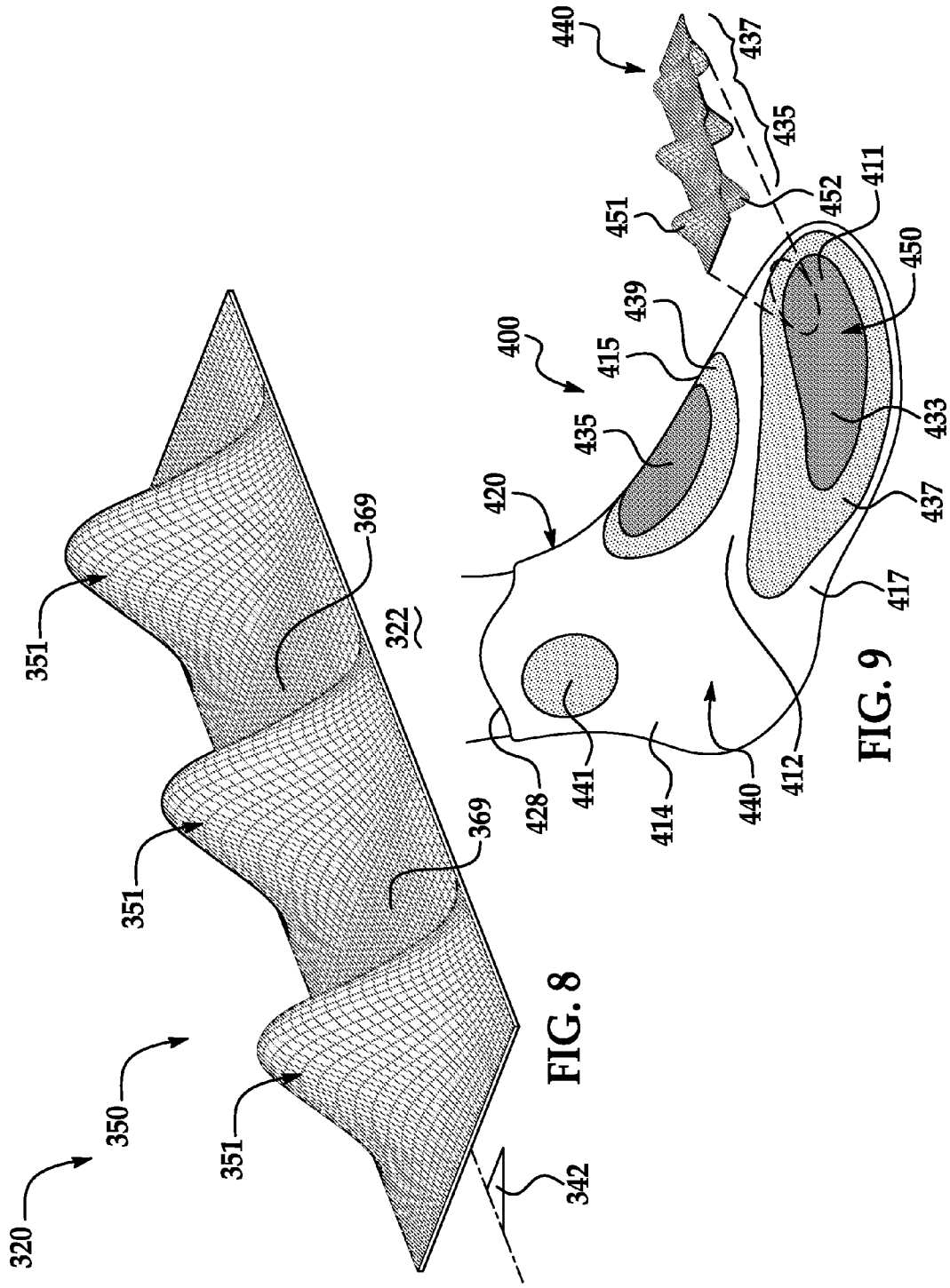
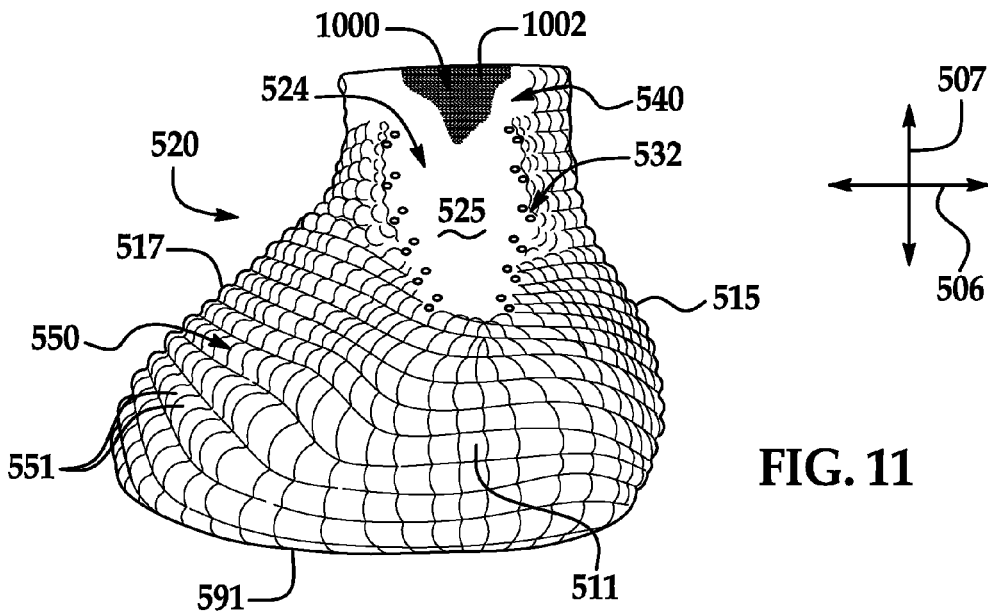
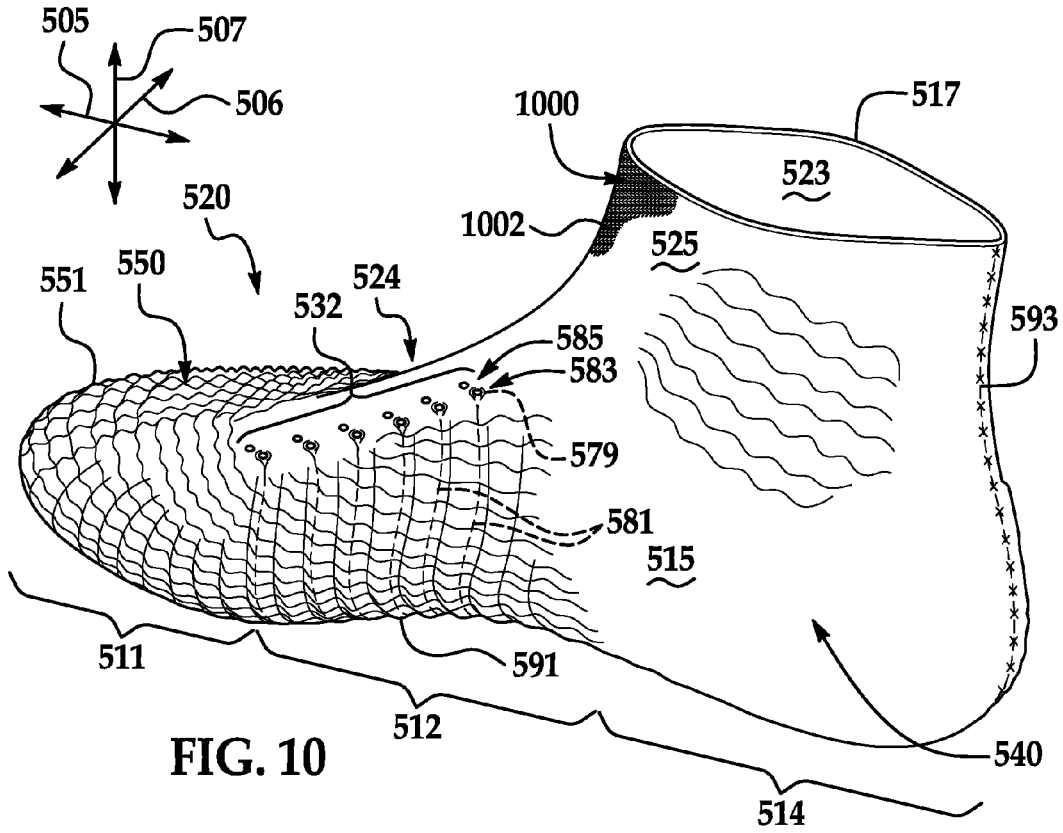
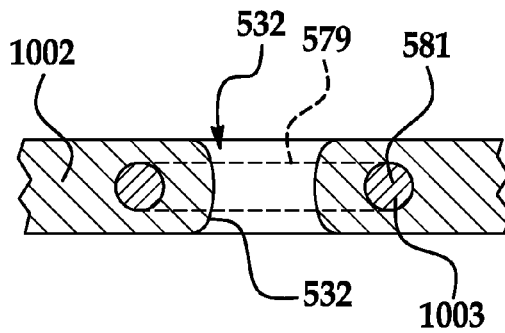
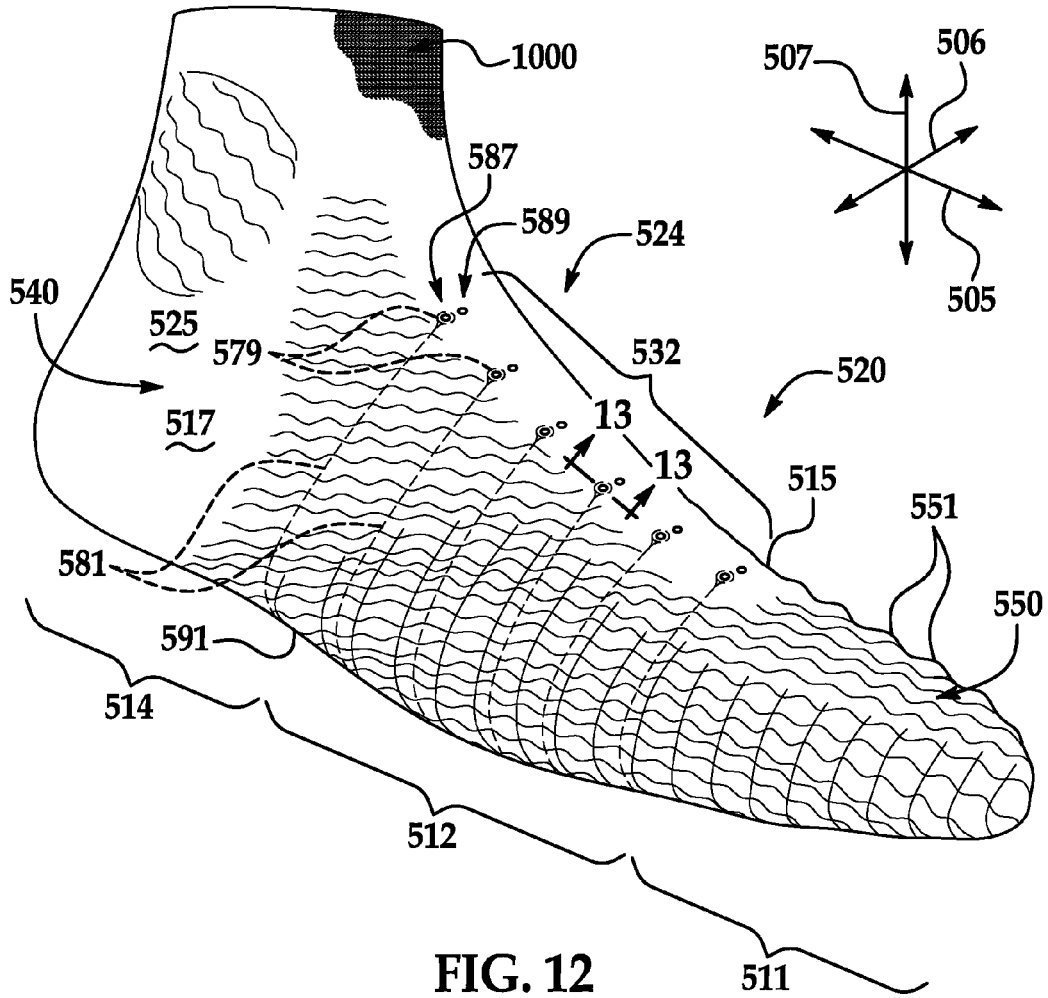

FIG. 8

FIG. 9





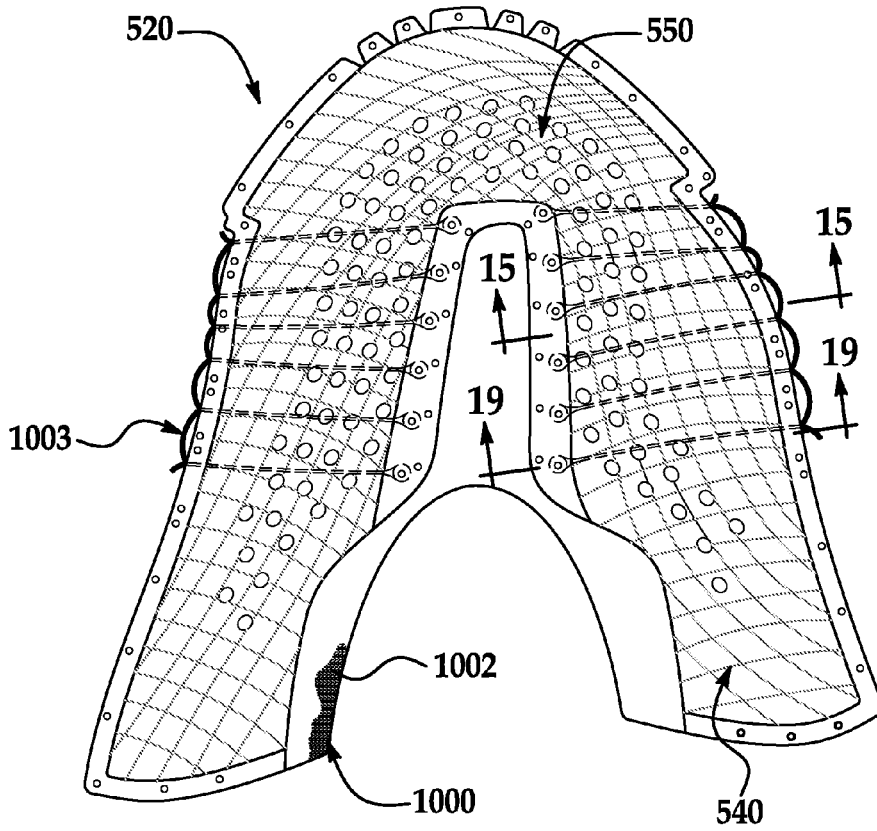

FIG. 14

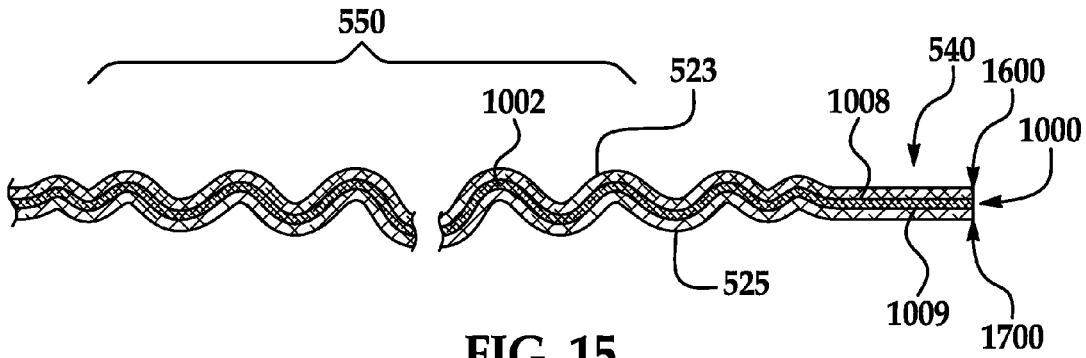

FIG. 15

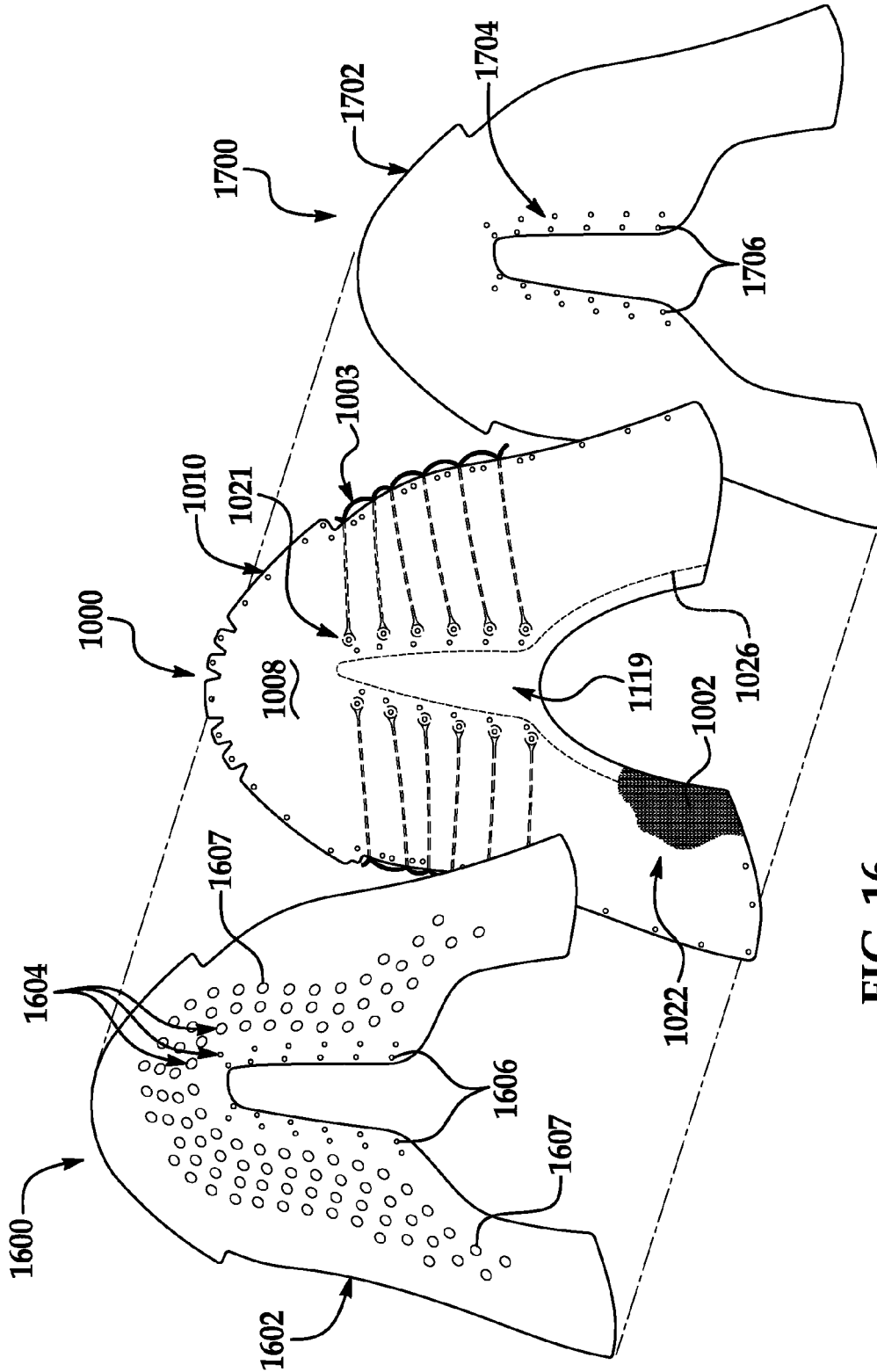

FIG. 16

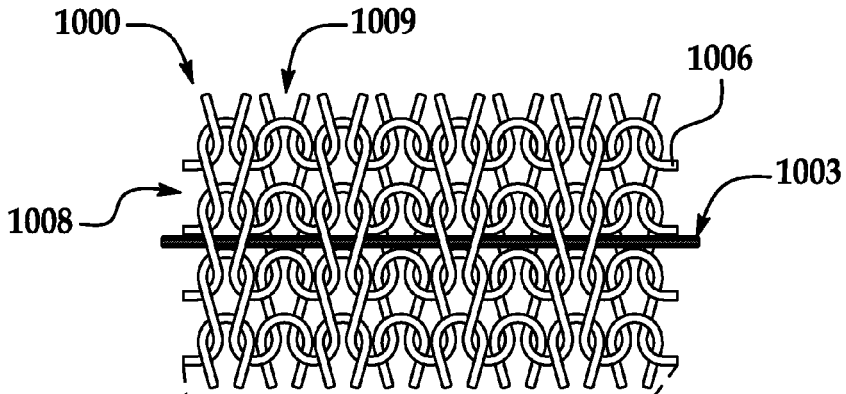

FIG. 18

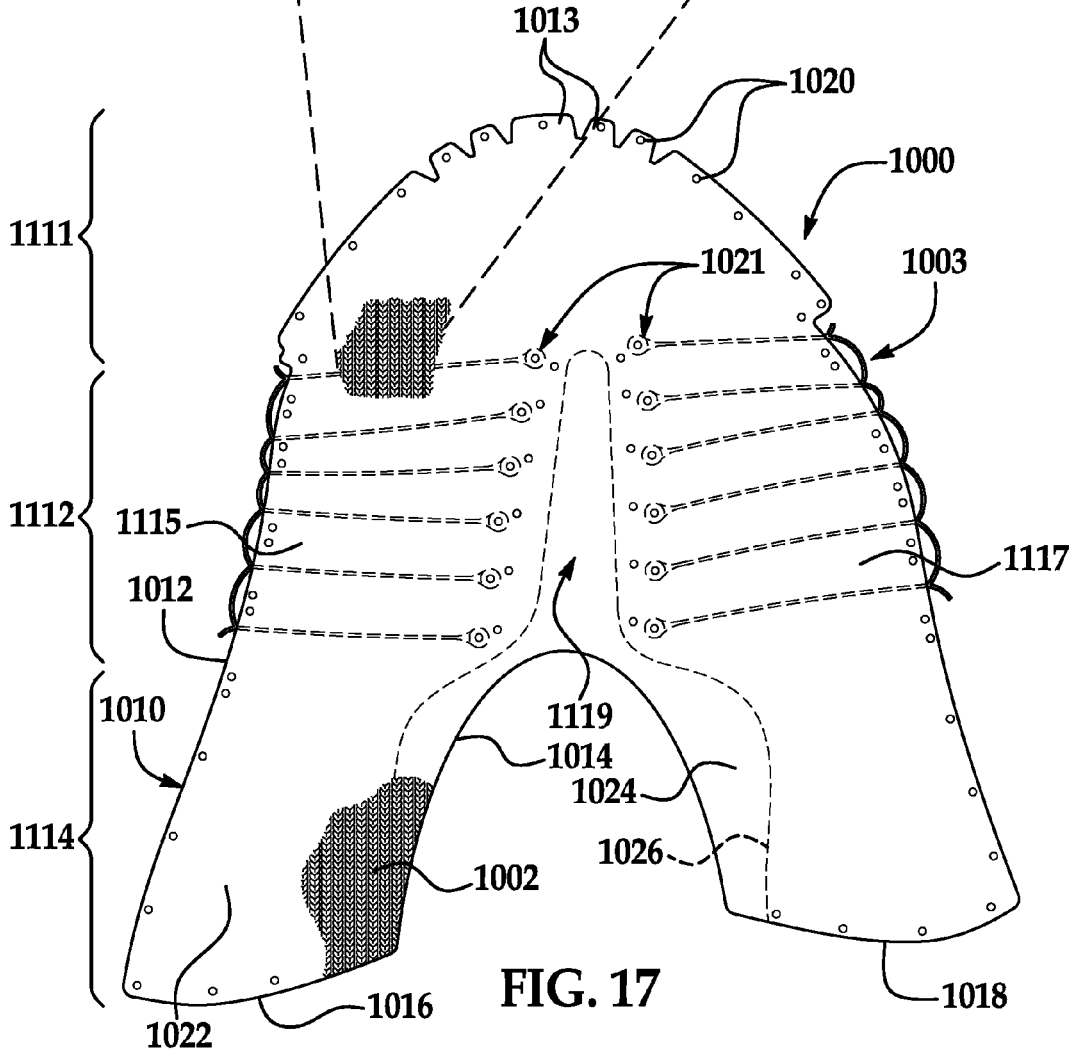

FIG. 17

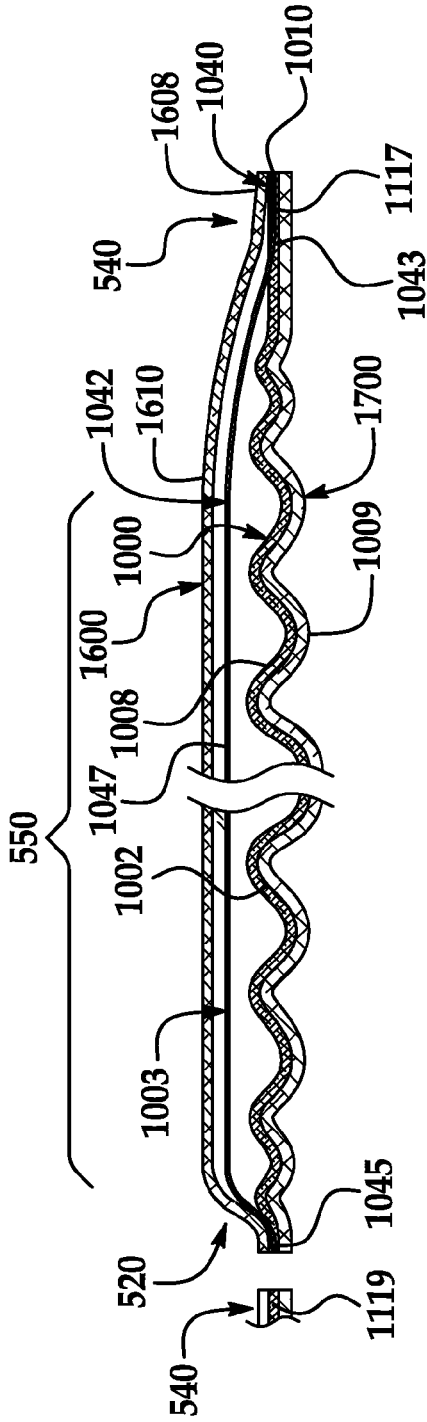

FIG. 19

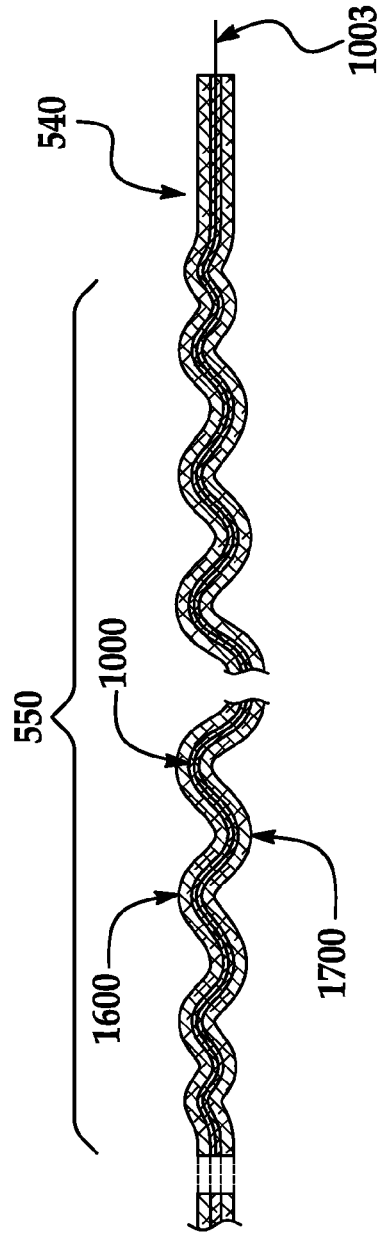

FIG. 20

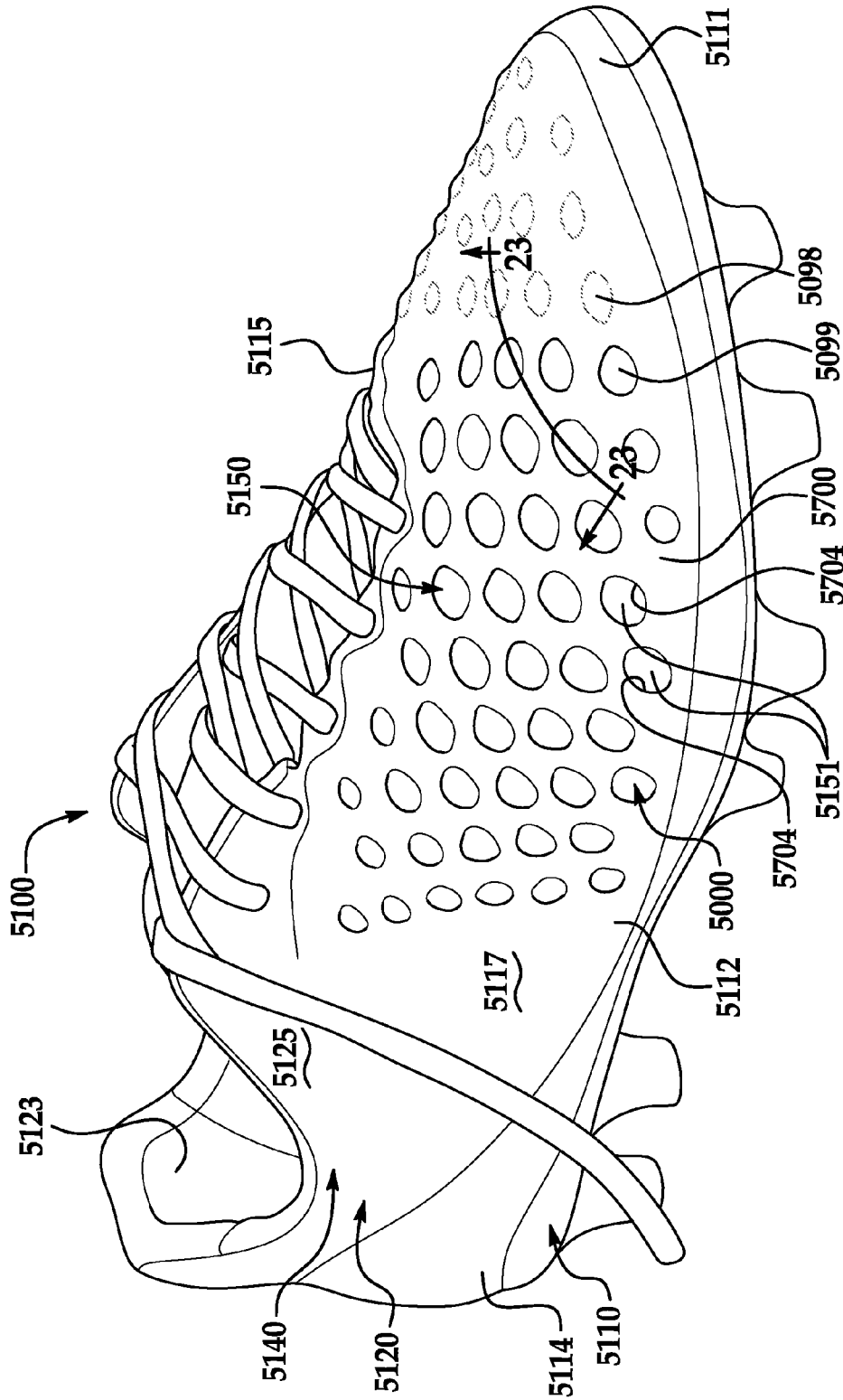

FIG. 21

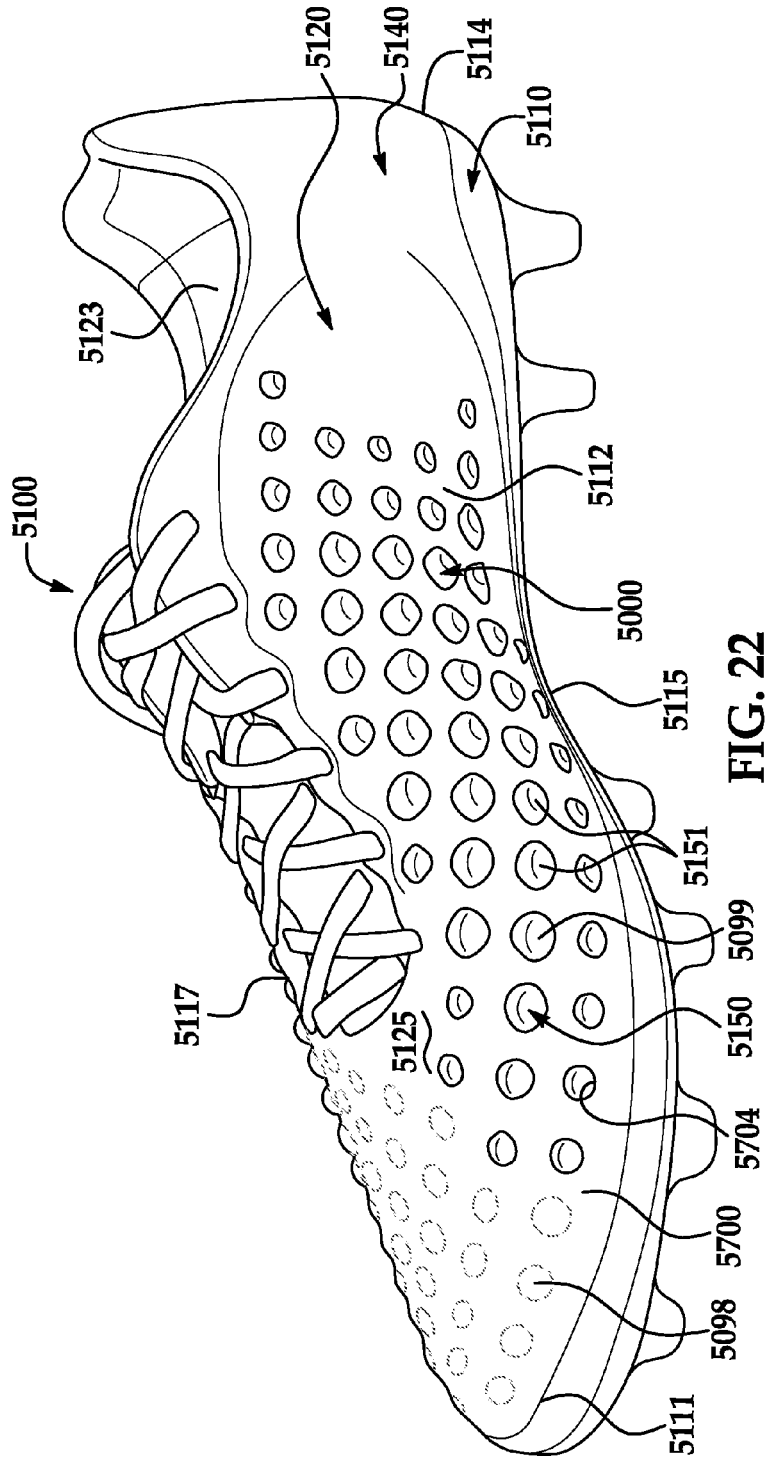

FIG. 22

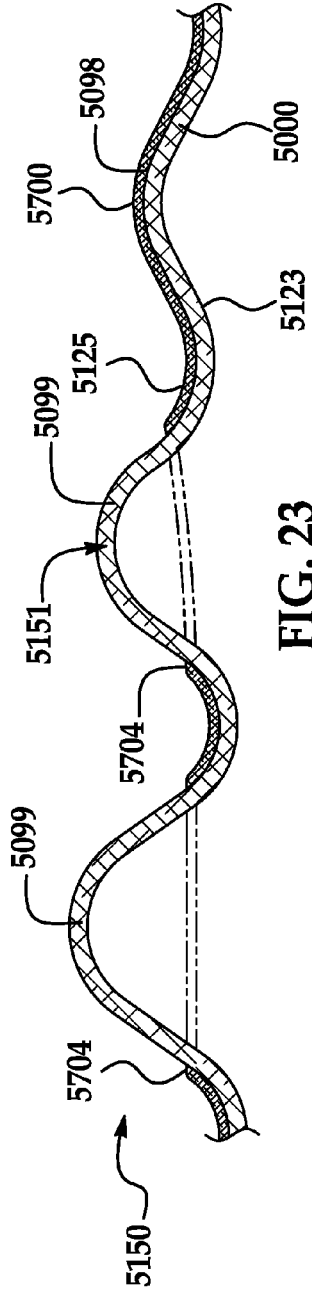

FIG. 23

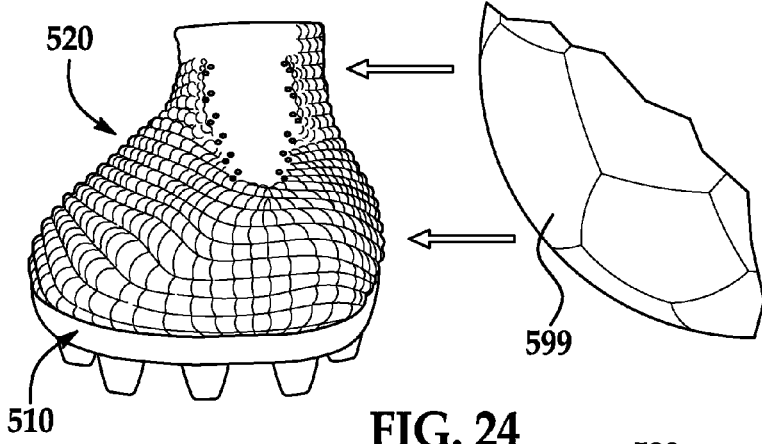

FIG. 24

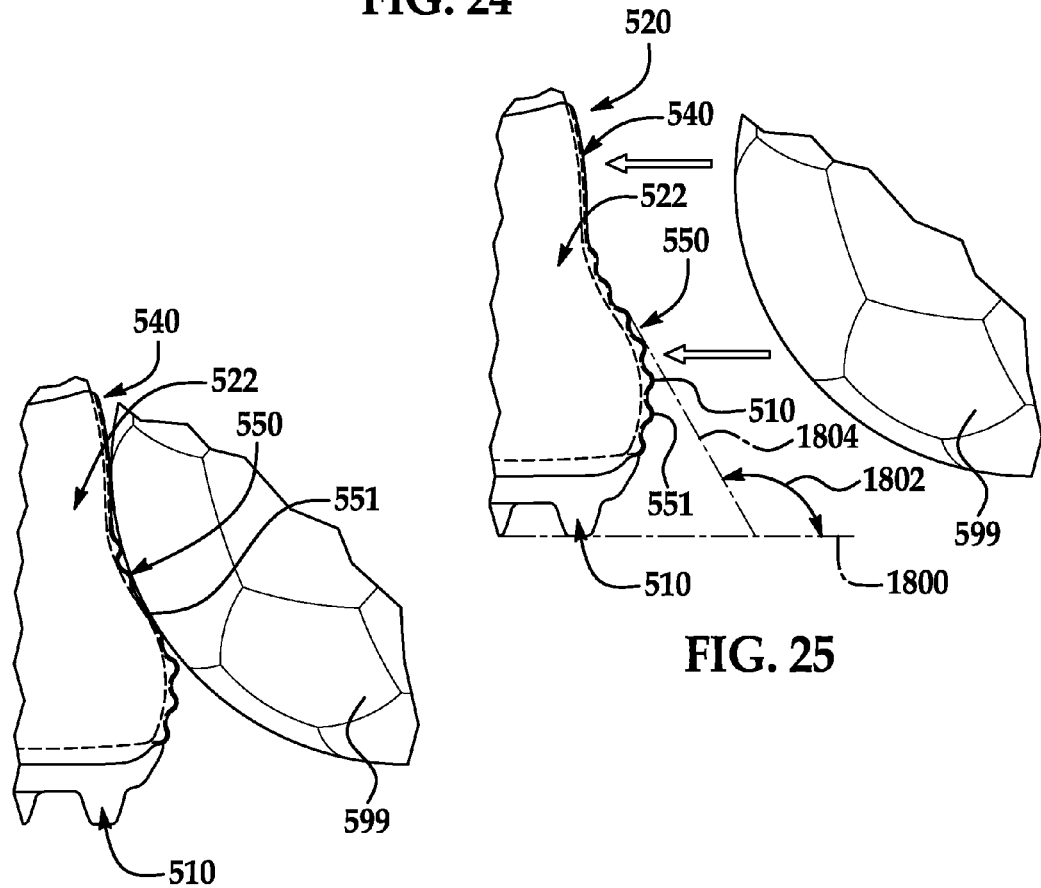

FIG. 25

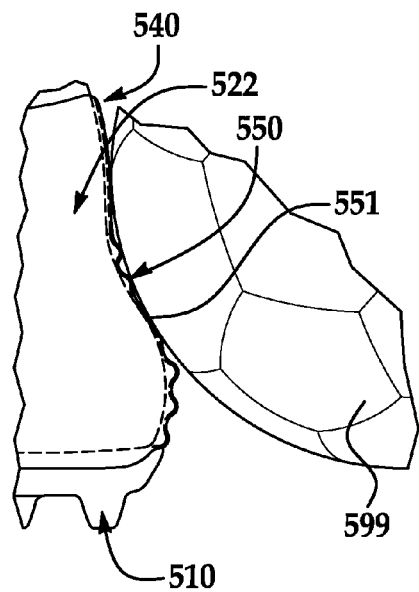

FIG. 26

**ARTICLE OF FOOTWEAR WITH KNITTED
COMPONENT HAVING PLURALITY OF
GRADUATED PROJECTIONS**

BACKGROUND

[0001] Conventional articles of footwear generally include two primary elements: an upper and a sole structure. The upper is secured to the sole structure and forms a cavity for comfortably and securely receiving a foot. The sole structure is secured to a lower area of the upper, thereby being positioned between the upper and the ground.

[0002] In some embodiments, the sole structure includes a midsole and an outsole. The midsole often includes a polymeric foam material that attenuates ground reaction forces to lessen stresses upon the foot and leg during walking, running, and other ambulatory activities. Additionally, the midsole may include fluid-filled chambers, plates, moderators, or other elements that further attenuate forces, enhance stability, or influence the motions of the foot. The outsole is secured to a lower surface of the midsole and provides a ground-engaging portion of the sole structure formed from a durable and wear-resistant material, such as rubber.

[0003] The upper can generally extend over the instep and toe areas of the foot, along the medial and lateral sides of the foot and around the heel area of the foot. In some articles of footwear, the upper may extend upward and around the ankle to provide support or protection for the ankle. Access to the cavity within the upper is generally provided by an ankle opening in a heel region of the footwear.

[0004] Additionally, the article of footwear can include a lacing system, cables, straps, buckles, or other securement device. The securement device can adjust the fit of the upper, thereby permitting entry and removal of the foot from the upper. The lacing system also permits the wearer to modify certain dimensions of the upper, particularly girth, to accommodate feet with varying dimensions.

BRIEF DESCRIPTION OF THE DRAWINGS

[0005] The present disclosure can be better understood with reference to the following drawings and description. The components in the figures are not necessarily to scale, emphasis instead being placed upon illustrating the principles of the present disclosure. Moreover, in the figures, like reference numerals designate corresponding parts throughout the different views.

[0006] FIG. 1 is a top view of an article of footwear according to exemplary embodiments of the present disclosure;

[0007] FIG. 2 is a medial perspective view of the article of footwear of FIG. 1;

[0008] FIG. 3 is a lateral perspective view of the article of footwear of FIG. 1;

[0009] FIG. 4 is a detail perspective view of a textured area of the article of footwear as indicated in FIG. 1 according to exemplary embodiments;

[0010] FIG. 5 is a section view taken along the line 5-5 of FIG. 1;

[0011] FIG. 6 is a section view of another portion of the upper of the article of footwear of FIG. 1;

[0012] FIG. 7 is a detail perspective view of a textured area of the article of footwear according to additional embodiments of the present disclosure;

[0013] FIG. 8 is a detail perspective view of a textured area of the article of footwear according to additional embodiments of the present disclosure;

[0014] FIG. 9 is a schematic view of the upper of the article of footwear according to additional embodiments;

[0015] FIG. 10 is a medial perspective view of an upper of the article of footwear according to additional embodiments of the present disclosure;

[0016] FIG. 11 is a front view of the upper of FIG. 10;

[0017] FIG. 12 is a lateral perspective view of the upper of FIG. 10;

[0018] FIG. 13 is a section view of the upper taken along the line 13-13 of FIG. 12;

[0019] FIG. 14 is a plan view of the upper of FIG. 10;

[0020] FIG. 15 is a section view of the upper taken along the line 15-15 of FIG. 14;

[0021] FIG. 16 is an exploded view of the upper of FIG. 10;

[0022] FIG. 17 is a plan view of a knitted component of the upper of FIG. 10;

[0023] FIG. 18 is a detail view of the knitted component of FIG. 17;

[0024] FIG. 19 is a section view of the upper taken along the line 19-19 of FIG. 14;

[0025] FIG. 20 is a section view of the upper according to additional embodiments;

[0026] FIG. 21 is a lateral perspective view of the article of footwear according to additional embodiments;

[0027] FIG. 22 is a medial perspective view of the article of footwear of FIG. 21;

[0028] FIG. 23 is a section view of the article of footwear taken along the line 23-23 of FIG. 21;

[0029] FIG. 24 is a front view of the article of footwear and a ball shown moving toward the footwear;

[0030] FIG. 25 is a section view of the article of footwear of FIG. 24, wherein the upper is shown prior to impact with the ball; and

[0031] FIG. 26 is a section view of the article of footwear of FIG. 24, wherein the upper is shown during impact with the ball,

DETAILED DESCRIPTION

[0032] The following discussion and accompanying figures disclose an upper of an article of footwear having predetermined areas that are textured. Also disclosed is an upper with a first area that is substantially smooth and a second area that is textured. Furthermore, methods of manufacturing uppers and articles of footwear having these features are disclosed.

[0033] In some embodiments, the textured area(s) of the upper can be deformable, for example, under compression. More specifically, the textured area(s) can flex, flatten out, stretch, or otherwise deform when the footwear impacts a ball or other object. Furthermore, the textured area(s) of the upper can be resilient. Thus, after impacting the ball or other object, the textured area(s) can recover from the deformed position to the neutral, textured position.

[0034] For example, an article of footwear is disclosed that includes a sole structure and an upper that is attached to the sole structure. The upper defines a cavity that is configured to receive a foot of a wearer. The upper is at least partially defined by a textile. The textile includes a first area that is substantially smooth. The first area defines a reference boundary that conforms to the cavity. The textile includes a

second area. The second area includes a plurality of projection structures. The projection structures comprise portions of the textile that project away from the reference boundary and outward from the cavity. Each of the projection structures have a height measured from the reference boundary. At least one projection structure differs in height from at least one other projection structure. The second area further includes a plurality of recess structures that recess away from the reference boundary and inward toward the cavity. The plurality of projection structures and the plurality of recess structures are in an alternating arrangement across the textile.

[0035] Furthermore, an article of footwear is disclosed that includes a sole structure and an upper that is attached to the sole structure. The upper defines a cavity that is configured to receive a foot of a wearer. The upper is at least partially defined by a knitted component that is formed of unitary knit construction. The upper includes a first area that is substantially smooth. The first area defines a reference boundary that substantially conforms to the cavity. The upper includes a second area that includes a plurality of projection structures that project away from the reference boundary and away from the cavity. The plurality of projection structures are at least partially defined by the knitted component. At least one of the plurality of projection structures includes a convex exterior surface and a concave interior surface. The convex exterior surface faces generally away from the cavity, and the convex exterior surface faces opposite the concave interior surface. The concave interior surface is open to the cavity.

[0036] In addition, a knitted component is disclosed that is formed of unitary knit construction and that is configured to at least partially form an upper. The upper is configured to define a cavity, which is configured to receive a foot. The upper is also configured to attach to a sole structure to form an article of footwear. The knitted component includes a first area that is substantially smooth. The first area defines a reference boundary, and the reference boundary is configured to substantially conform to the cavity. The knitted component further includes a second area. The second area includes a plurality of projection structures that project away from the reference boundary at a respective height. The plurality of projection structures are arranged in a gradient pattern such that the height gradually increases across the gradient pattern.

[0037] These and other details of the present disclosure will be explored in the various exemplary embodiments illustrated in the Figures. It will be appreciated that the articles of footwear and methods of manufacture of the present disclosure can vary from these embodiments. Other systems, methods, features and advantages of the present disclosure will be, or will become, apparent to one of ordinary skill in the art upon examination of the following figures and detailed description. It is intended that all such additional systems, methods, features and advantages be included within this description and this summary, be within the scope of the present disclosure, and be protected by the following claims.

[0038] Footwear Configurations

[0039] Referring initially to FIGS. 1-3, an article of footwear **100** is illustrated according to exemplary embodiments. Footwear **100** is disclosed as having a general configuration suitable for soccer, football, or other activities involving kicking. Concepts associated with the footwear

100 may also be applied to a variety of other athletic footwear types, including baseball shoes, basketball shoes, cross-training shoes, cycling shoes, sprinting shoes, tennis shoes, and hiking boots, for example. The concepts may also be applied to footwear types that are generally considered to be non-athletic, including dress shoes, loafers, sandals, and work boots. The concepts disclosed herein apply, therefore, to a wide variety of footwear types.

[0040] For reference purposes, footwear **100** may be divided into three general regions: a forefoot region **111**, a midfoot region **112**, and a heel region **114**. Forefoot region **111** can generally include portions of footwear **100** corresponding with forward portions of the wearer's foot, including the toes and joints connecting the metatarsals with the phalanges. Midfoot region **112** can generally include portions of footwear **100** corresponding with middle portions of the wearer's foot, including an arch area. Heel region **114** can generally include portions of footwear **100** corresponding with rear portions of the wearer's foot, including the heel and calcaneus bone.

[0041] Footwear **100** can also include a medial side **115** and a lateral side **117**. Medial side **115** and lateral side **117** can extend through forefoot region **111**, midfoot region **112**, and heel region **114** in some embodiments. Medial side **115** and lateral side **117** can correspond with opposite sides of footwear **100**. More particularly, medial side **115** can correspond with an inside area of the wearer's foot and can face toward the wearer's other foot. Lateral side **117** can correspond with an outside area of the wearer's foot and can face away from the wearer's other foot.

[0042] Forefoot region **111**, midfoot region **112**, heel region **114**, lateral side **117**, and medial side **115** are not intended to demarcate precise areas of footwear **100**. Rather, forefoot region **111**, midfoot region **112**, heel region **114**, lateral side **117**, and medial side **115** are intended to represent general areas of footwear **100** to aid in the following discussion. These terms can also be used in reference to individual components of footwear **100**.

[0043] Footwear **100** can also extend along various directions. For example, as shown in FIGS. 1-3, footwear **100** can extend along a longitudinal direction **105** as well as a transverse direction **106**. Also, as shown in FIGS. 2 and 3, footwear **100** can extend along a vertical direction **107**. Longitudinal direction **105** can extend generally between heel region **114** and forefoot region **111**. Transverse direction **106** can extend generally between lateral side **117** and medial side **115**. Also, vertical direction **107** can extend substantially perpendicular to both longitudinal direction **105** and transverse direction **106**.

[0044] Generally, footwear **100** can include a sole structure **110** and an upper **120**. Upper **120** can receive the wearer's foot and secure footwear **100** to the wearer's foot whereas sole structure **110** can extend underneath upper **120** and provide cushioning, traction, and/or support for the wearer's foot.

[0045] As shown in FIGS. 2-3, sole structure **110** can be secured to upper **120** and can extend underneath the wearer's foot. Sole structure **110** can include an attachment area **108** that faces upper **120** and that is fixed to upper **120**. Attachment area **108** can be adhesively attached, lasted, or otherwise attached to upper **120**. Also, sole structure **110** can include an outer periphery surface **103** that extends about footwear **100** and that extends in the vertical direction **107** between the upper **120** and the ground. Sole structure **110**

can further include a ground engaging surface 109 that opposes the ground or floor. In some embodiments, ground engaging surface 109 can be defined by an outsole. Sole structure 110 can additionally include a midsole that includes padding, foam, fluid-filled bladders, or other components that provide cushioning, dampening of impact loads, and the like.

[0046] Also, in some embodiments, sole structure 110 can have one or more projections, such as cleats 104. In other embodiments, sole structure 110 can include ribs or other bodies that project from ground engaging surface 109.

[0047] As shown in FIGS. 2-3, upper 120 can extend generally upward in the vertical direction 107 from attachment area 108, between medial side 115 and lateral side 117 of sole structure 110, and longitudinally from forefoot region 111 to heel region 114 of sole structure 110. Upper 120 can define a void or cavity 122 within footwear 100. Stated differently, upper 120 can include an inner surface 123 that defines cavity 122. Cavity 122 can receive a foot of a wearer. Upper 120 can additionally include an outer surface 125 that faces opposite inner surface 123. Upper 120 can also define a collar 128 with an upper edge 129 that defines a collar opening 121. Collar opening 121 can provide access to cavity 122 and can allow passage of the foot into and out of upper 120.

[0048] Upper 120 can also include a throat 124 that extends in the longitudinal direction 105 between forefoot region 111 and collar 128, and in the transverse direction 106 between medial side 115 and lateral side 117. In some embodiments, throat 124 can include a tongue. In some embodiments, tongue can be attached to forefoot region 111 of upper 120 and can be detached from medial side 115 and/or lateral side 117. In other embodiments, such as the embodiments of FIGS. 1-3, upper 120 can be substantially continuous between medial side 115 and lateral side 117 across throat 124. As such, upper 120 can be “sock-like” and “tongue-less.”

[0049] Additionally, in some embodiments, footwear 100 can include a securement element 127, such as a shoelace, cable, wire, strap, buckle, or other suitable implements for securing upper 120 to the wearer's foot. In other embodiments, such as the embodiment of FIGS. 1-3, footwear 100 can be more “sock-like,” “lace-less,” and/or otherwise without a securement element. In some embodiments, upper 120 can constrict and compress against the wearer's foot for securing footwear 100 to the wearer's foot.

[0050] As shown in the embodiments of FIGS. 1-3, upper 120 can include a shoelace 130. Shoelace 130 can be laced through a plurality of eyelets 132 included in upper 120, proximate throat 124. In other additional embodiments, shoelace 130 can be secured to upper 120 via hooks or other lace receiving elements.

[0051] In some embodiments, upper 120 can extend both over the wearer's foot and underneath the wearer's foot. Portions of upper 120 extending underneath the wearer's foot and can be layered and attached to sole structure 110. Additionally, it will be appreciated that any underfoot part of the upper 120 can be referred to as a “strobel,” a “strobel sock,” or a “strobel part.”

[0052] In further configurations, upper 120 may include additional elements. For example, upper 120 can include a toe guard in forefoot region 101 that is formed of a wear-resistant material. Upper 120 can additionally include logos, trademarks, symbols, and placards with care instructions and

material information. Those having ordinary skill in the art will appreciate that upper 120 can include still further elements without departing from the scope of the present disclosure.

[0053] Also, footwear 100 can additionally include a sockliner that extends underneath the wearer's foot. For example, the sockliner can be a removable insert that is provided within the cavity 122 and that provides a padded surface underneath the wearer's foot. In some embodiments, a strobel of upper 120 can be disposed between the sockliner and sole structure 110.

[0054] Furthermore, in some embodiments, upper 120 can include a plurality of different regions, areas, or zones that differ in one or more characteristics. For example, upper 120 can include a plurality of regions that differ in surface textures.

[0055] For example, upper 120 can include one or more substantially smooth areas 140 and one or more textured areas 150. It will be appreciated that the embodiment of textured area 150 is shown schematically in FIG. 1 with a group of ovals that are each filled with stippling. FIGS. 2 and 3 illustrate upper 120 generally in a topographic fashion with textured area 150 illustrated with contoured lines. In contrast, smooth areas 140 are illustrated in FIGS. 2 and 3 either with substantially straight lines or with unlined areas.

[0056] Smooth areas 140 can generally conform to the cavity 122 within upper 120 and generally conform to the wearer's foot. Also, smooth area 140 can be flat and planar, or smooth area 140 can exhibit some degree of curvature. However, any curvature of smooth area 140 can substantially conform to the outer boundary of the cavity 122 within upper 120. Also, smooth area 140 of upper 120 can conform and nest against the wearer's foot. With this arrangement, smooth area 140 provides an approximately even and/or regular surface across portions of upper 120. Moreover, in some embodiments, smooth area 140 can define a reference boundary 142, which is indicated, for example, in FIGS. 4 and 5, and which substantially corresponds to the cavity 122 within upper 120. Thus, the reference boundary 142 defined by smooth area 140 can also substantially conform to the outer surface curvature of the wearer's foot.

[0057] In contrast to smooth area 140, textured areas 150 can include projections and/or recesses that produce surface height variations across upper 120. For example, in some embodiments, the textured areas 150 can include bumps, waves, corrugations, ripples, scales, undulations or other surface features. In some embodiments represented in FIGS. 4 and 5, textured area 150 can include a plurality of projection structures 151 that project outwardly from the cavity 122 and outward from the reference boundary 142 defined by smooth area 140. Also, in some embodiments, textured area 150 can further include a plurality of recess structures 152 that recess into cavity 122 and inward from the reference boundary 142.

[0058] The projection structures 151 and recess structures 152 can have any suitable arrangement within textured area 150. For example, in some embodiments, the projection structures 151 and recess structures 152 can be disposed in an alternating arrangement. Thus, a typical recess structure 152 can be disposed between at least two projection structures 151. Similarly, a typical projection structure 151 can be disposed between at least two recess structures 152. This alternating arrangement can be repeated across the textured area 150.

[0059] Furthermore, in some embodiments, different projection structures 151 can differ in one or more dimensions. For example, the different projection structures 151 can differ in height, width, radius, or other dimensions. Similarly, in some embodiments, different recess structures 152 can differ in one or more dimensions. For example, different recess structures 152 can differ in depth, width, radius, or other dimensions.

[0060] Smooth areas 140 and textured areas 150 can be included on predetermined portions of upper 120. For example, in some embodiments, smooth areas 140 can be located where more support, stiffness, and/or stretch resistance is needed. In some embodiments shown in FIGS. 1-3, smooth areas 140 can be located substantially in heel region 114. In additional embodiments, smooth areas 140 can be disposed proximate the attachment area 108 of sole structure 110, and the smooth areas 140 can facilitate attachment (i.e., lasting) of the sole structure 110 to the upper 120. Furthermore, in some embodiments, smooth areas 140 can be located in throat 124 of upper 120. In contrast, textured areas 150 can be located on medial side 115 and lateral side 117 of midfoot region 112 as well as in forefoot region 111 in some embodiments. The upper 120 can include a single textured area 150 in some embodiments. In other embodiments, the upper 120 can include a plurality of textured areas 150.

[0061] In some embodiments, the locations of smooth areas 140 and/or textured areas 150 can be determined based on the sport or activity for which the article of footwear will be used. Thus, in some embodiments, textured areas 150 can be included in portions of upper 120 used for kicking, passing, trapping, or otherwise controlling a ball. Still further, in some embodiments, textured areas 150 can also be included on the collar 128, for example, to cover at least one malleolus of the wearer. In some embodiments, textured areas 150 can increase the outer surface area of upper 120 for grip of a ball or other object. Also, textured areas 150 can provide the wearer with better control and tactile sensation of the ball. Furthermore, textured areas 150 can distribute pressure relatively evenly across upper 120. In addition, textured areas 150 can be configured for directing drainage of rainwater or other liquids off of upper 120.

[0062] Moreover, in some embodiments, the textured area 150 can be resilient and deformable. For example, in some embodiments, textured area 150 can deform and flatten out when textured area 150 impacts a ball or other object. Then, textured area 150 can resiliently recover back to the more textured state. Accordingly, this resilient deformation can dampen and dissipate the impact energy. Thus, the wearer may be able to more reliably trap a soccer ball, the wearer may be better able to direct the ball when kicking and passing, and/or the textured area 150 can provide increased tactile feel of the ball when controlling the ball. Also, textured area 150 can provide padding and/or cushioning for the wearer.

[0063] Configurations of Smooth Area and Textured Area of Upper

[0064] Embodiments of substantially smooth area 140 and textured area 150 will now be discussed in detail. FIGS. 4-6 illustrate smooth areas 140 and textured 150 in detail according to exemplary embodiments.

[0065] A portion of smooth area 140 is shown in FIGS. 4-6 according to some embodiments. In some embodiments, smooth area 140 can be regular and even and can define

reference boundary 142. Also, in some embodiments, smooth area 140 can have a substantially constant thickness 143 (FIG. 5), which is measured between inner surface 123 and outer surface 125 of upper 120. Accordingly, smooth area 140 can layer over, cover, and/or nest against the wearer's foot.

[0066] In contrast, textured area 150 can include the plurality of projection structures 151. In some embodiments, the textured area 150 can have substantially the same thickness 143 as the smooth area 140. As representative examples, the plurality of projections structures 151 illustrated in FIGS. 4 and 5 include a first projection structure 154, a second projection structure 156, a third projection structure 158, and a fourth projection structure 160. In some embodiments, the plurality of projection structures 151 can resemble rounded bumps or bulges.

[0067] More specifically, as shown in FIGS. 4 and 5, projection structures 151 can each include an apex 153 and a side portion 155. Also, as shown in FIG. 4, side portion 155 can be three-dimensionally curved, and side portion 155 can terminate at the apex 153. Also, as shown in FIG. 5, apex 153 can be projected outward from the reference boundary 142 at a height 162. In some embodiments, the height 162 of the projection structures 151 can range between approximately 0.002 inches and 0.5 inches. Furthermore, as shown in FIG. 5, projection structure 151 can have a width 163, which is measured between opposing areas of side portion 155, proximate the reference boundary 142. In some embodiments, the width 163 of projection structures 151 can range between approximately 0.002 inches and 0.5 inches.

[0068] Furthermore, as shown in FIGS. 4 and 5, projection structure 151 can define a respective convex exterior portion 164 of outer surface 125 of upper 120. Portion 164 can also be referred to as a "convex exterior surface" of projection structure 151. Additionally, projection structure 151 can define a respective concave interior portion 166 of inner surface 123 of upper 120. Portion 166 can also be referred to as a "concave interior surface" of projection structure 151.

[0069] Textured area 150 of upper 120 can also include the plurality of recess structures 152. As representative examples, the plurality of recess structures 152 illustrated in FIGS. 4 and 5 include a first recess structure 168, a second recess structure 170, and a third recess structure 172. In some embodiments, the plurality of recess structures 152 can resemble rounded divots or pockets.

[0070] More specifically, as shown in FIGS. 4 and 5, recess structures 152 can each include a nadir 174 and a side portion 176. Also, as shown in FIG. 4, side portion 176 can be three-dimensionally curved, and side portion 176 can terminate at the nadir 174. Also, as shown in FIG. 5, nadir 174 can be recessed inward from the reference boundary 142 at a depth 178. In some embodiments, the depth 178 of the recess structures 152 can range between approximately 0.002 inches and 0.5 inches. Furthermore, as shown in FIG. 5, recess structure 152 can have a width 179, which is measured between opposing areas of side portion 176, proximate the reference boundary 142. In some embodiments, the width 179 of recess structures 152 can range between approximately 0.1 inches and 0.5 inches.

[0071] Furthermore, as shown in FIGS. 4 and 5, recess structure 152 can define a respective concave exterior portion 180 of outer surface 125 of upper 120. Portion 180 can also be referred to as a concave exterior surface of recess structure 152. Additionally, recess structure 152 can define

a respective convex interior portion **182** of inner surface **123** of upper **120**. Portion **182** can also be referred to as a convex interior surface of recess structure **152**.

[0072] As shown in FIGS. 4-6, projection structures **151** and recess structures **152** can be disposed in an alternating arrangement. Stated differently, the recess structures **152** can be disposed between respective pairs of projection structures **151**. Similarly, the projection structures **151** can be disposed between respective pairs of recess structures **152**. More specifically, as shown in FIGS. 4 and 5, first recess structure **168** can be disposed between first projection structure **154** and second projection structure **156**, second recess structure **170** can be disposed between second projection structure **156** and third projection structure **158**, and third recess structure **172** can be disposed between third projection structure **158** and fourth projection structure **160**.

[0073] As shown in FIG. 4, textured area **150** can include a transition **169** between a recess structure **152** and a projection structure **151** that are adjacent to each other. In some embodiments, transition **169** can be at partially co-extensive with reference boundary **142**. Transition **169** can also be referred to as an “adjacent area” to projection structure **151** and/or recess structure **152**.

[0074] The features of the projection structures can vary in a number of ways. For example, FIG. 7 illustrates a plurality of projection structures **251** and a plurality of recess structures **252** according to additional embodiments. Projection structures **251** and recess structures **252** can share corresponding features to those of FIGS. 4-6. Those corresponding features are indicated in FIG. 7 with corresponding reference numbers increased by **100**.

[0075] As shown, in some embodiments, projection structures **251** can include at least one flat surface. In some embodiments, projection structures **251** can include four flat surfaces that meet at an apex **253**. Accordingly, in some embodiments, projection structures **251** can be hollow and pyramidal. Likewise, in some embodiments, recess structures **252** can include at least one flat surface. In some embodiments, recess structures **252** can include four flat surfaces that meet at a nadir **274**. Accordingly, in some embodiments, recess structures **252** can be hollow and inversely pyramidal. Furthermore, transitions **269** between adjacent pairs of projection structures **251** and recess structures **252** can be coextensive with the reference boundary **242**. Also, in some embodiments, the transitions **269** can be linear.

[0076] Referring now to FIG. 8, additional embodiments of projection structures **351** of textured surface **350** are illustrated. Projection structures **351** can share corresponding features to those of FIGS. 4-6. Those corresponding features are indicated in FIG. 8 with corresponding reference numbers increased by **200**.

[0077] As shown, in some embodiments, textured surface **350** can include rounded, hollow, convex projection structures **351**, similar to projection structures **151** of FIG. 4. Textured surface **350** can also include transitions **369** that are defined between adjacent pairs of projection structures **351**. In some embodiments, transitions **369** can be substantially coextensive with reference boundary **342**. Transitions **369** can, thus, substantially conform to the cavity **322** within upper **320**. Furthermore, in some embodiments, projection structures **351** can project away from the adjacent transition **369**. It will also be appreciated that textured surface **350** projects in a single direction relative to cavity **322** within

upper **320**. Stated differently, textured surface **350** of FIG. 8 projects outwardly from cavity **322** and does not include recess structures of the type disclosed in connection with FIGS. 4 and 7.

[0078] Referring back to FIGS. 1-3, textured surfaces **150** will be additionally discussed. As shown, in some embodiments, projection structures **151** and recess structures **152** can be arranged in rows. These rows can extend across the upper **120** in any direction. The rows can also extend along a linear axis or along a curved axis across upper **120**. For example, as shown in the embodiment of FIG. 2, projection structures **151** can be arranged in a plurality of rows **173** that curve from medial side **115**, across forefoot region **111** toward lateral side **117**. In other embodiments, rows **173** can extend generally in the vertical direction **107**, between the throat **124** and the sole structure **110**. Also, in some embodiments, rows **173** can extend in the longitudinal direction **105** and/or in transverse direction **106**. In other embodiments, projection structures **151** and recess structures **152** can be randomly arranged across upper **120**.

[0079] Moreover, in some embodiments, the plurality of projection structures **151** within textured area **150** can vary in one or more dimensions. For example, the heights of the projection structures **151** can vary across textured area **150**. Specifically, as shown in the exemplary embodiment of FIG. 5, the height **162** of first projection structure **154** can be greater than a height **184** of second projection structure **156**. Furthermore, the height **184** of second projection structure **156** can be greater than a height **186** of third projection structure **158**. Also, the height **186** of third projection structure **158** can be greater than a height **188** of fourth projection structure **160**. Additionally, in some embodiments, the width **168** of projection structures **151** can also vary between different projection structures **151**.

[0080] Likewise, in some embodiments, one or more dimensions of the plurality of recess structures **152** can vary across textured area **150**. For example, as shown in FIG. 5, the depth **178** of first recess structure **168** can be greater than a depth **190** of second recess structure **170**. Also, the depth **190** of second recess structure **170** can be greater than a depth **192** of third recess structure **172**. Additionally, in some embodiments, the width **179** of recess structures **152** can also vary between different recess structures **152**.

[0081] In some embodiments, the heights of the projection structures **151** can vary such that the projection structures **151** are arranged in a gradient pattern. For example, the heights of the projection structures **151** can vary gradually from projection structure **151** to adjacent projection structure **151** along the gradient pattern. In some embodiments, those projection structures **151** that are more centrally located within textured area **150** can be the tallest, and the projection structures **151** can be gradually shorter the closer those projection structures **151** are to the smooth area **140**. Accordingly, as shown in FIG. 5, the first projection structure **154** can have the greatest height **162** relative to the second, third, and fourth projection structures **156**, **158**, **160**. The second projection structure **156** can have a slightly smaller height **184**, the third projection structure **158** can have a height **186** that is smaller still, and the fourth projection structure **160** can have the smallest height **188**. In some embodiments, fourth projection structure **160** can be located proximate a transition **194**, which is defined between textured area **150** and smooth area **140** of upper **120**.

[0082] Furthermore, in some embodiments, the depths of the recess structures 152 can vary such that the recess structures 152 are arranged in a gradient pattern. For example, the depths of the recess structures 152 can vary gradually along the gradient pattern. In some embodiments, those recess structures 152 that are more centrally located within textured area 151 can be the deepest, and the recess structures 152 can be gradually shallower the closer those recess structures 152 are to the smooth area 140. Accordingly, as shown in FIG. 5, the first recess structure 168 can have the greatest depth 178 relative to the second and third recess structures 170, 172. The second recess structure 170 can have a slightly smaller depth 190, and the third recess structure 172 can have the shallowest depth 192.

[0083] Similarly, in some embodiments represented in FIG. 5, the widths 163 of the projection structures 151 can vary such that the projection structures 151 are arranged in a gradient pattern. Stated differently, the widths 163 of the projection structures 151 can vary gradually from projection structure 151 to adjacent projection structure 151 along the gradient pattern. Likewise, the widths 179 of the recess structures 152 can vary such that the recess structures 152 are arranged in a gradient pattern. Stated differently, the widths 179 of the recess structures 152 can vary gradually from recess structure 152 to adjacent recess structure 152 along the gradient pattern.

[0084] FIG. 6 further illustrates this gradient pattern within textured area 150. As shown, medial side 115 of upper 120 and lateral side 117 of upper 120 can both include respective smooth areas 140, and textured area 150 can extend across forefoot area 111. As shown, the tallest projection structures 151 and the deepest recess structures 152 can be located centrally within forefoot area 111. The projection structures 151 can be gradually shorter and the recess structures 152 can be gradually shallower in the direction moving toward the medial side 115. Likewise, the projection structures 151 can be gradually shorter and the recess structures 152 can be gradually shallower in the direction moving toward the lateral side 117. In additional embodiments, the gradient pattern of textured area 150 can be arranged such that projection structures 151 are gradually shorter in the longitudinal direction 105. In further embodiments, the gradient pattern of textured area 150 can be arranged such that projection structures 151 are gradually shorter in the vertical direction 107.

[0085] The gradient arrangement within textured area 150 can provide certain benefits. For example, the gradient arrangement can allow textured area 150 to distribute forces and/or deform in a predetermined manner when impacting an object. More specifically, in some embodiments, taller projection structures 151 can deform readily when impacting a ball, and forces can be distributed through textured area 150 such that the gradually shorter projection structures 151 can resist deformation. The gradient pattern can also enhance the force dampening properties of textured area 150. Furthermore, in some embodiments, the gradient pattern of projection structures 151 can provide the wearer with enhanced grip for controlling a ball or other object. Moreover, the gradient pattern can allow upper 120 to channel water or other fluids away from upper 120 in a predetermined manner. Still further, the gradient pattern can make textured area 150 more aesthetically appealing.

[0086] FIG. 9 illustrates the arrangement of the textured areas 450 of the upper 420 according to additional embodi-

ments. The upper 420 is shown schematically for purposes of clarity. The embodiment of FIG. 9 can include components and features that are similar to the embodiments discussed above with respect to FIGS. 1-6. Those components that correspond to those of FIGS. 1-6 are indicated with corresponding reference numbers increased by 300.

[0087] As shown, upper 420 can include a plurality of textured areas 450 and one or more smooth areas 440. Textured areas 450 are indicated schematically with stippling, and the stippling is absent from smooth areas 440. Also, inset within FIG. 9 is a representative arrangement of projection structures 451 and recess structures 452 within textured areas 450. Thus, textured area 450 can be similar to the embodiments of FIGS. 4-6. However, it will be appreciated that textured areas 450 can be similar to the embodiments of FIG. 7 or 8 without departing from the scope of the present disclosure.

[0088] In some embodiments, upper 420 can include a lateral textured area 443, a medial textured area 445, and a malleolus textured area 447. Lateral textured area 443, medial textured area 445, and malleolus textured area 447 can be spaced apart from each other with substantially smooth areas 440 spanning between.

[0089] Lateral textured area 443 can be disposed in the forefoot region 411, on the lateral side 417 of upper 420 so as to correspond generally with the outer toes and metatarsals of the wearer's foot. Medial textured area 445 can be disposed in the midfoot region 412, on the medial side 415 so as to correspond generally with the arch of the wearer's foot. Malleolus textured area 441 can be disposed generally in the heel region 414, proximate the collar 428, on the lateral side 417 so as to correspond to the lateral malleolus of the wearer's ankle. Although not shown in FIG. 9, upper 420 can also include a similar textured area on the malleolus area of the medial side 415.

[0090] Projection structures 451 and recess structures 452 can be arranged in a gradient as discussed above. For example, projection structures 451 can gradually reduce in height across textured area 450. Projection structures 451 can be shorter and shorter in a direction moving toward adjacent smooth area 440 to define a relatively smooth transition between textured areas 450 and smooth areas 440. Also, in some embodiments, recess structures 452 can gradually reduce in depth across textured area 450 to define a relatively smooth transition between textured areas 450 and smooth areas 440.

[0091] This gradient arrangement is illustrated schematically in FIG. 9. For example, the taller projection structures 451 within lateral textured area 443 can be disposed in a high texture area 433, which is illustrated with dense stippling, and which can be centrally located within lateral textured area 443. The shorter projection structures 451 can be disposed in a reduced texture area 433, which is illustrated with less dense stippling, and which can surround high texture area 433. Thus, reduced texture area 433 can define a transition between high texture area 433 and adjacent smooth area 440.

[0092] Likewise, the taller projection structures 451 within medial textured area 445 can be disposed in a high texture area 437, which is illustrated with dense stippling, and which can be centrally located within medial textured area 445. The shorter projection structures 451 can be disposed in a reduced texture area 439, which is illustrated with less dense stippling, and which can at least partially

surround high texture area 437. In some embodiments, reduced texture area 439 can define a transition between high texture area 437 and adjacent smooth area 440.

[0093] Upper 120 can also include indicia that visually indicate the gradient pattern of the textured area 450. For example, in some embodiments, the upper 420 can vary in color across upper 420 for this purpose. This is represented schematically in FIG. 9 with the different stippling patterns that are shown. In some embodiments, for example, high texture area 433 and high texture area 437 can be colored darker than reduced texture area 435 and reduced texture area 439. Textured areas 450 can also be colored darker than smooth areas 440. Also, in some embodiments, textured area 450 can appear as a gradient of gradually changing indicia that corresponds to the gradient of gradually taller projection structures 451 within textured area 450. For example, in some embodiments, the smooth areas 440 can have a light shade of a color, and the shade of that color can darken as the upper 420 spans into the textured areas 450. Furthermore, within the textured area 450, the shade of that color can gradually darken proximate the high texture area 433 and the high texture area 437. In additional embodiments, projection structures 451 can have a single color and surrounding areas can have a different color. As such, larger projection structures 451 can be more visually apparent than smaller projection structures 451.

[0094] Referring now to FIGS. 10-12, upper 520 is illustrated according to additional embodiments. Upper 520 is shown without a sole structure for purposes of clarity, but it will be appreciated that a sole structure can be attached without departing from the scope of the present disclosure. The embodiments of FIGS. 10-12 can include components and features that are similar to the embodiments discussed above. Those components that correspond to those of FIGS. 1-6 are indicated with corresponding reference numbers increased by 400.

[0095] Upper 520 can include one or more substantially smooth areas 540 and one or more textured areas 550. For example, smooth areas 540 of upper can be included generally in heel region 514 and in throat 524. Also, textured areas 550 can be included generally on medial side 515 and lateral side 517 of midfoot region 512 and in forefoot region 511.

[0096] Also, in some embodiments, textured area 550 can include projection structures 551 as shown. Projection structures 551 can be configured as rounded bumps, similar to the embodiments of FIGS. 4-6 and 8. In other embodiments, projection structures 551 can include at least one flat surface, similar to the embodiments of FIG. 7. Projection structures 551 can also have other shapes and configurations without departing from the scope of the present disclosure. Furthermore, in some embodiments, textured area 550 can additionally include recess structures, similar to the embodiments of FIGS. 4-7.

[0097] In some embodiments, projection structures 551 can be arranged in a gradient as discussed above. More specifically, in some embodiments, the heights of the projection structures 551 can vary across textured area 550. In some embodiments, the projection structures 551 in the forefoot region 511 can be the tallest. Also, projection structures 551 can gradually reduce in height in a direction moving rearward toward smooth areas 540 at heel region 514 and/or upward toward throat 524. In some embodiments, projection structures 551 can gradually reduce in

height such that textured area 550 substantially blends into smooth area 540 at the transition 594 between textured area 550 and smooth area 540.

[0098] Moreover, in some embodiments, the projection structures 551 can be arranged tallest to shortest in the vertical direction 507 such that relatively short projection structures 551 are disposed proximate a sole attachment area 591, where upper 520 attaches to a sole structure. Accordingly, the upper 520 can be smoother at sole attachment area 591, thus facilitating attachment of the sole structure.

[0099] Furthermore, upper 520 can include a plurality of eyelets 532, which can receive a shoelace or other similar securement device. As shown in FIG. 10, eyelets 532 can be arranged in a plurality of rows that extend generally in the longitudinal direction 505, along either side of throat 524. Specifically, as shown in the embodiment of FIG. 10, eyelets 532 can be arranged in an outer medial row 583 and an inner medial row 585. Furthermore, as shown in the embodiment of FIG. 12, eyelets 532 can be further arranged in an outer lateral row 587 and an inner lateral row 589.

[0100] Still further, in some embodiments, upper 520 can include one or more tensile elements 581. In some embodiments, tensile elements 581 can be elongate, flexible, and strong. Also, tensile elements 581 can extend across and can be attached to areas of upper 520 for providing support. More specifically, in some embodiments, tension within tensile elements 581 can allow the upper 520 to resist deformation, stretching, or otherwise provide support for the wearer's foot when running, jumping, kicking, or otherwise moving.

[0101] It will be appreciated that upper 520 can include any number of tensile elements 581. Also, tensile elements 581 can be made of a variety of materials and can have a variety of shapes and dimensions. Also, tensile elements 581 can extend across any suitable portion of upper 520. In FIGS. 10-12, tensile elements 581 are shown extending away from sole attachment area 591 in the vertical direction 507 toward throat 524. In some embodiments, tensile elements 581 can extend away from sole attachment area 591 to predetermined eyelets 532. For example, in the embodiments of FIGS. 10-12, tensile element 581 can form a loop 579 that encircles an eyelet 532 in either the outer medial row 583 or the outer lateral row 587. One or more loops 579 can be disposed internally within upper 520 in some embodiments as represented in FIG. 13. Alternatively, loops 579 can extend out of upper 520 and can be external of upper 520 in some embodiments. When a shoelace extends through the eyelet 532, the shoelace can be received through the loop 579. Also, loop 579 can reinforce areas of upper 520 adjacent the eyelet 532.

[0102] Moreover, in some embodiments, upper 520 can include a seam 593 as shown, for example, in FIG. 10. Seam 593 can be defined where opposing edges of upper 520 are joined, for example, by stitching, adhesives, fasteners, or other attachment devices. In some embodiments, the opposing edges of upper 520 can be butted and secured together to define seam 593. In other embodiments, the opposing edges 520 can be overlapped and secured together to define seam 593. Furthermore, in some embodiments, seam 593 can be defined at heel region 514 so as to extend along the Achilles heel of the wearer.

[0103] Embodiments of Materials and Construction of Upper

[0104] The upper of the present disclosure can be constructed from any suitable materials. Also, the upper can be constructed from one or more parts. In some embodiments, the upper can be formed from multiple material elements (e.g., polymer foam, polymer sheets, leather, synthetic leather) that are joined together through stitching, adhesives, bonding, or fasteners, for example.

[0105] In other embodiments, the majority of the upper can be formed from a unitary, monolithic, single-body. As such, the upper can be constructed in an efficient manner and can include a relatively low number of parts. Additionally, the upper can flex with, conform against, and/or nest against the wearer's foot because of the single-body construction.

[0106] Furthermore, in some embodiments, the upper can be made from one or more sheet-like layers. As shown in the embodiment of FIGS. 15 and 16, for example, the upper can be constructed from a plurality of layers. In other embodiments, the upper can be made from a single layer.

[0107] Additionally, in some embodiments, the upper of the present disclosure can be at least partially formed from a textile element or fabric. Specifically, the upper can be at least partially formed via a knitting process in some embodiments. In other embodiments, the upper can be at least partially formed via a weaving process. As such, the upper can be lightweight, breathable, and soft to the touch. However, the textile can be constructed such that the upper is durable and strong. Moreover, the knitting or weaving processes can provide manufacturing efficiencies and can result in a relatively low amount of waste. Also, the textile can provide elasticity to the upper. For example, the textile can have some degree of elasticity due to the knitted or woven construction. Furthermore, in some embodiments, the textile can be knitted or woven from elastic and stretchable yarns, which further enhance the stretchiness of the upper.

[0108] The construction and materials of upper will be discussed according to exemplary embodiments with reference to FIG. 17, which corresponds to the upper 520 of FIGS. 10-12. These features can also be included in other embodiments without departing from the scope of the present disclosure. In some embodiments, upper 520 can include a textile in the form of a knitted component 1000 as shown FIG. 17. Knitted component 1000 can at least partially extend through forefoot region 111, midfoot region 512, and/or heel region 514 of upper 520. Knitted component 1000 can also extend along medial side 515 and lateral side 517, over forefoot region 511, and/or around heel region 514.

[0109] As will be discussed, knitted component 1000 can provide the upper 520 with weight savings as compared with other conventional uppers. Additionally, in some embodiments, knitted component 1000 can be configured with textured area 550 and smooth area 540. Still further, knitted component 1000 can provide advantages in the manufacture of the article of footwear. Other advantages due to the knitted component 1000 will be explored in detail below.

[0110] In some embodiments, knitted component 1000 can be made at least partially through a flat knitting or circular knitting process. An exemplary flat-knitted component 1000 is shown in plan view in FIG. 17.

[0111] Knitted component 1000 can be formed of unitary knit construction. As defined herein and as used in the

claims, the term "unitary knit construction" means that knitted component 1000 is formed as a one-piece element through a knitting process. That is, the knitting process substantially forms the various features and structures of knitted component 1000 without the need for significant additional manufacturing steps or processes. An example of unitary knit construction of upper 520 is illustrated in FIG. 18. As shown, unitary knit construction may be used to form a knitted component 1000 having courses 1008 and wales 1009. Also, unitary knit construction may be used to form a knitted component 1000 with structures or elements that are joined such that the structures or elements include at least one course 1008 or wale 1009 in common (i.e., sharing a common strand or common yarn). Also, one or more courses 1008 and/or wales 1009 can be substantially continuous between each portion of knitted component 1000. With this arrangement, a one-piece element of unitary knit construction is provided.

[0112] Although portions of knitted component 1000 may be joined to each other following the knitting process, knitted component 1000 remains formed of unitary knit construction because it is formed as a one-piece knit element. Moreover, knitted component 1000 remains formed of unitary knit construction when other elements (e.g., an inlaid strand, a closure element, logos, trademarks, placards with care instructions and material information, and other structural elements) are added following the knitting process.

[0113] Thus, upper 520 can be constructed with a relatively low number of material elements. This can decrease waste while also increasing the manufacturing efficiency and recyclability of upper 520. Additionally, knitted component 1000 of upper 520 can incorporate a smaller number of seams or other discontinuities. This can further increase manufacturing efficiency of the article of footwear. Moreover, inner surface 523 and outer surface 525 of upper 520 can be substantially smooth and uniform due to knitted component 1000 to enhance the overall comfort and fit of the article of footwear.

[0114] In some embodiments, knitted component 1000 can be primarily defined by a knit element 1002. As shown in FIG. 18, knit element 1002 of knitted component 1000 may be formed from at least one yarn 1006, cable, fiber, filament, or other strand that is manipulated (e.g., with a knitting machine) to form a plurality of intermeshed loops that define a plurality of courses 1008 and wales 1009.

[0115] Knitted component 1000 can also generally include at least one tensile element 1003. In some embodiments, tensile element 1003 can be a yarn, cable, fiber, filament, or other elongate strand. Tensile element 1003 can extend across and can be attached to knit element 1002. In some embodiments, tensile element 1003 can be inlaid within a course and/or a wale of knit element 1002. As such, the tensile elements 1003 can be formed of unitary knit construction with knit element 1002. In other embodiments, at least one or more segments of tensile element 1003 can be external to knit element 1002.

[0116] Tensile elements 1003 can provide support to knitted component 1000. More specifically, in some embodiments, tension within tensile elements 1003 can allow knitted component 1000 to resist deformation, stretching, or otherwise provide support for knit element 1002. Tensile elements 1003 of FIG. 17 can correspond to the tensile elements 581 of FIGS. 10, 12, and 13.

[0117] Knitted component **1000**, knit element **1002**, and/or tensile element **1003** can incorporate the teachings of one or more of commonly-owned U.S. Pat. No. 8,490,299 to Dua et al., filed on Dec. 18, 2008, and granted on Jul. 23, 2013, and U.S. patent application Ser. No. 13/048,514 to Hun et al., entitled “Article Of Footwear Incorporating A Knitted Component,” filed on Mar. 15, 2011 and published as U.S. Patent Application Publication Number 2012/0233882 on Sep. 20, 2012, both of which are hereby incorporated by reference in their entirety.

[0118] Knit element **1002** can be formed from one or more yarns **1006** of any suitable type. For example, at least one yarn **1006** of knit element **1002** can be made from cotton, elastane, rayon, wool, nylon, polyester, or other material. Furthermore, in some embodiments, yarn **1006** can include thermoplastic polyurethane (TPU). Also, in some embodiments, at least one yarn **1006** can be elastic and resilient. As such, yarn **1006** can be elongated from a first length, and yarn **1006** can be biased to recover to its first length. Thus, such an elastic yarn **1006** can allow knit element **1002** to stretch elastically and resiliently under the influence of a force. When that force is reduced, knit element **1002** can recover back its neutral position.

[0119] Furthermore, in some embodiments, at least one yarn **1006** can be at least partially formed from a thermoset polymer material that can melt when heated and that can return to a solid state when cooled. As such, yarn **1006** can be a fusible yarn and can be used to join two objects or elements together. In additional embodiments, knit element **1002** can include a combination of fusible and non-fusible yarns. In some embodiments, for example, knitted component **1000** and upper **520** can be constructed according to the teachings of U.S. Patent Publication No. 2012/0233882, which published on Sep. 20, 2012, the disclosure of which is hereby incorporated by reference in its entirety.

[0120] Additionally, in some embodiments, a single yarn **1006** can form each of the courses and wales of knit element **1002**. In other embodiments, knit element **1002** can include a plurality of yarns **1006**. For example, different yarns **1006** can form different courses and/or different wales. In additional embodiments, a plurality of yarns can be plated together and can cooperate to define a common loop, a common course and/or a common wale of knit element **1002**. Moreover, in some embodiments, knit element **1002** can be constructed with a relatively high stitch density. Also, in some embodiments, knit element **1002** can be constructed using a relatively high-gauge knit, such as a full-gauge knit. Accordingly, knit element **1002** can be constructed to hold its textured shape.

[0121] Tensile element **1003** can be attached to and engaged with knit element **1002** in any suitable fashion. For example, in some embodiments, at least a portion of tensile element **1003** can be inlaid within one or more courses **1008** and/or wales **1009** of knit element **1002** such that tensile element **1003** can be incorporated during the knitting processes on the knitting machine. More specifically, as shown in the embodiment of FIG. 18, tensile element **1003** can alternate between being located: (a) behind loops formed from yarn **1006**; and (b) in front of loops formed from yarn **1006**. In effect, tensile element **1003** weaves through the unitary knit construction of knit element **1002**. As a result, in some embodiments, tensile element **1003** can be disposed within knit element **1002** between the front and back surfaces of knit element **1003**.

[0122] Features of knitted component **1000** illustrated in FIG. 17 will now be discussed in greater detail according to exemplary embodiments. Knitted component **1000** can define features of the upper **520** shown in FIGS. 10-12. As such, knitted component **1000** can include a forefoot region **1111**, a midfoot region **1112**, and a heel region **1114** that define forefoot region **511** of upper **520**, midfoot region **512** of upper **520**, and heel region **1114** of upper **520**, respectively. Also, knitted component **1000** can include a medial side **1115** that defines medial side **515** of upper **520**, and knitted component **1000** can include a lateral side **1117** that defines lateral side **517** of upper **520**. Furthermore, knitted component **1000** can include a throat region **1119** that defines throat **524** of upper **520**.

[0123] In FIG. 17, knitted component **1000** is shown in plan view such that knitted component **1000** appears flat and sheet-like. An outer boundary of knitted component **1000** can be defined by a peripheral edge **1010**. Also, knitted component **1000** can include a front surface **1008** that spans between opposing segments of peripheral edge **1010**. Although not shown in FIG. 17, knitted component **1000** can also include a back surface that opposes front surface **1008**.

[0124] Peripheral edge **1010** can be sub-divided into a plurality of segments. For example, peripheral edge **1010** can include a substantially U-shaped outer segment **1012**. Edge **1010** can also include a substantially U-shaped inner segment **1014**. Moreover, edge **1010** can include a third end segment **1016** and a fourth end segment **1018**. Third end segment **1016** and/or fourth end segment **1018** can be substantially straight. Also, third end segment **1016** can extend between the outer segment **1012** and inner segment **1014** proximate medial side **1115**, and second end segment **1018** can extend between outer segment and inner segment **1012**, **1014** proximate lateral side **1117**.

[0125] In some embodiments, outer segment of peripheral edge can include one or more scallops **1013**. Scallops **1013** can be separated by generally triangular-shaped cutouts along peripheral edge **1010**. Also, scallops **1013** can be disposed primarily in forefoot region **1111**. Furthermore, when knitted component **1000** is assembled into a three-dimensional shape, scallops **1013** can allow adjacent portions of knitted component **1000** to overlay each other and form a highly curved area of upper **520** without bunching.

[0126] When assembled into the three-dimensional upper, front surface **1008** of knitted component **1000** can face inner surface **523** of upper **520**, and the opposing back surface can face outer surface **525** of upper **520**. In some embodiments, front surface **1008** can define inner surface **523** of upper **520**, and/or the opposing back surface can define outer surface **525** of upper **520**. In other embodiments, a skin or other object can be layered and attached to one or both surfaces of knitted component **1000**, and the skin or other object can define the inner surface **523** and/or outer surface **525** of upper **520**.

[0127] Furthermore, in some embodiments, knitted component **1000** can include one or more openings. In some embodiments, the openings can be through-holes that extend through the front surface **1008** and the opposing back surface. For example, the knitted component **1000** can include eyelet openings **1020** that form the eyelets **532** discussed above. Also, the knitted component **1000** can include one or more indexing openings **1020**. In some embodiments, the indexing openings **1020** can be arranged along peripheral edge **1010**. For example, indexing openings

1020 can be included along outer segment **1012** of peripheral edge **1010**. Also, at least some indexing openings **1020** can be included proximate scallops **1013**. Indexing openings **1020** can also be included proximate first end **1016** and second end **1018** of knitted component **1000**. Indexing openings **1020** can be used for pinning or otherwise anchoring knitted component **1000** to a support structure during manufacturing.

[0128] Knitted component **1000** can also define a plurality of zones that differ in one or more characteristics. For example, in the embodiment of FIG. 17, knitted component **1000** can include a first zone **1022** and a second zone **1024**. First zone **1022** is demarcated from second zone **1024** by a boundary line **1026** in FIG. 17 according to exemplary embodiments.

[0129] In some embodiments, second zone **1024** can have greater stretching elasticity than first zone **1022**. For example, second zone **1024** can stretch out elastically at least 20% more than first zone **1022** when subjected to a common stretching force. In additional embodiments, second zone **1024** can stretch out elastically at least 40% more than first zone **1022** when subjected to a common stretching force.

[0130] These stretching and elasticity characteristics can be observed and measured in various ways. For example, when the knitted component **1000** is unstretched and in a neutral position, the widths of first zone **1022** and second zone **1024** can be measured in a direction extending generally between the medial side **1115** and the lateral side **1117**. Then, a stretching force or load can be applied to stretch and elongate the knitted component **1000**. The increase in widths of first zone **1022** and second zone **1024** can then be calculated. In additional embodiments, independent specimens of first zone **1022** and second zone **1024** can be stretch tested individually and compared. Additionally, in some cases, these stretching and elasticity characteristics can be measured using the procedure set forth in ASTM D2594. In other cases, these stretching and elasticity characteristics can be measured using other industry-accepted standard testing procedures.

[0131] In the embodiment of FIG. 17, for example, the second zone **1024** can be disposed substantially in throat region **1119**. Also, second zone **1024** can extend substantially about inner segment **1014** of peripheral edge **1010**.

[0132] The difference in elasticity can be a result of knitting second zone **1024** from yarns that are more elastic than the yarns knitted in the first zone **1022**. Also, fusible yarns can be knitted and fused within first zone **1022**, whereas second zone **1024** can be devoid of fusible yarns.

[0133] Skin Layer Configuration

[0134] In some embodiments, one or more objects can be added or attached to the knitted component **1000**. The knitted component **1000** and the additional object(s) can cooperate to define upper **520**. The object can be of any suitable type, such as a skin layer, a lines, a toe guarding member, a heel counter, a decal, a tag, fasteners, lace-receiving elements, or other types. The object can be attached in various ways as well.

[0135] In some embodiments, the object can be attached proximate to the front surface **1008** of knitted component **1000**. In added embodiments, the object can be attached proximate to the opposing back surface of knitted compo-

nent **1000**. In still other embodiments, the object can be attached proximate the peripheral edge of knitted component **1000**.

[0136] In some embodiments, the attached object can strengthen or provide reinforcement to predetermined areas of upper **520**. Also, the object can repel moisture in some embodiments. Furthermore, the object can insulate the upper **520** in some embodiments.

[0137] For example, as shown in FIGS. 15 and 16, upper **520** can include knitted component **1000** as well as one or more skin layers. In some embodiments, a skin layer can be layered on the front surface **1008**. A skin layer can also be layered on the opposing back surface of knitted component **1000**. As shown in the illustrated embodiment, upper **520** can include knitted component **1000**, a first skin layer **1600**, and a second skin layer **1700**.

[0138] First skin layer **1600** can lay adjacent to front surface **1008** of knitted component **1000** and can be secured to knitted component **1000** to form a portion of inner surface **523** of upper **520**. Also, as shown in FIG. 15, second skin layer **1700** can lay adjacent to back surface **1009** of knitted component **1000** and can be secured to knitted component **1000** to form a portion of outer surface **525** of upper **520**.

[0139] As noted above, first skin layer **1600** and/or second skin layer **1700** may be formed from a polymer (e.g., polyurethane) sheet, elements of leather or synthetic leather, microfiber, a woven or non-woven textile, or a metal foil. When formed as a polymer sheet or polymer layer, first skin layer **1600** and/or second skin layer **1700** may initially be a polymer film, polymer mesh, polymer powder, or polymer resin, for example. With any of these structures, a variety of polymer materials may be utilized for skin layers **1600**, **1700** including polyurethane, polyester, polyester polyurethane, polyether polyurethane, and nylon. An example of a non-woven textile with thermoplastic polymer filaments that may be bonded to knitted component **1000** is disclosed in U.S. Patent Application Publication 201010199406 to Due, et al., which is incorporated herein by reference. Moreover, additional considerations relating to first skin layer **1600** and second skin layer **1700** may be found in U.S. Patent Application Publication 201210246973 to Due, which is incorporated herein by reference.

[0140] Although skin layers **1600**, **1700** may be formed from a thermoset polymer material, some configurations of skin layers **1600**, **1700** can be formed from thermoplastic polymer materials (e.g., thermoplastic polyurethane). In general, a thermoplastic polymer material softens or melts when heated and returns to a solid state when cooled. More particularly, the thermoplastic polymer material transitions from a solid state to a softened or liquid state when subjected to sufficient heat, and then the thermoplastic polymer material transitions from the softened or liquid state to the solid state when sufficiently cooled. As such, the thermoplastic polymer material may be melted, molded, cooled, re-melted, re-molded, and cooled again through multiple cycles. Thermoplastic polymer materials may also be welded or thermal bonded to textile elements, such as knitted component **1000**.

[0141] in some configurations of upper **520**, a single element of first skin layer **1600** can be secured throughout knitted component **1000** and can cover a majority of knitted component **1000**. Likewise, in some configurations of upper **520**, a single element of second skin layer **1700** can be secured throughout knitted component **1000** and can cover a majority of knitted component **1000**. In further configu-

rations, however, different elements of the skin layer(s) may be formed from different materials and positioned in separate areas of knitted component 1000. That is, a portion of first skin layer 1600 formed from one material may be bonded to one area of knitted component 1000, and another portion of first skin layer 1600 formed from another material may be bonded to a different area of knitted component 1000. Similarly, a portion of second skin layer 1700 formed from one material may be bonded to one area of knitted component 1000, and another portion of second skin layer 1700 formed from another material may be bonded to a different area of knitted component 1000.

[0142] By varying the materials forming skin layer(s) 1600, 1700, different properties may be applied to different areas of upper 520. In other configurations, skin layer(s) 1600, 1700 may only cover specific areas of knitted component 1000, thereby leaving other areas of knitted component 1000 exposed. Skin layer(s) 1600, 1700 may, therefore, be absent from some areas of knitted component 1600, 1700.

[0143] As shown in the embodiment of FIG. 16, first skin layer 1600 can include an outer periphery 1602 that corresponds generally with peripheral edge 1010 of knitted component 1000. Also, in some embodiments, first skin layer 1600 can include a plurality of openings 1604, such as through-holes. For example, first skin layer 1600 can include a plurality of eyelet openings 1606 and a plurality of central openings 1607. Eyelet openings 1606 can align with corresponding eyelet openings 1021 of knitted component 1000. Also, the central openings 1607 can be spaced apart from each other and can be distributed across first skin layer 1600. Openings 1607 can generally reduce the weight, permeability, and/or breathability of upper 520. Furthermore, when attached to knitted component 1000, first skin layer 1600 can be disposed generally in the first zone 1022 of knitted component 1000. Thus, first skin layer 1600 can be absent from the more elastic second zone 1024 of knitted component 1000.

[0144] Also, as shown in the embodiment of FIG. 16, second skin layer 1700 can include an outer periphery 1702 that corresponds generally with peripheral edge 1010 of knitted component 1000. Also, in some embodiments, second skin layer 1700 can include a plurality of openings 1704, such as through-holes. For example, second skin layer 1700 can include a plurality of eyelet openings 1706 that can align with corresponding eyelet openings 1021 of knitted component 1000. Furthermore, when attached to knitted component 1000, second skin layer 1700 can be disposed generally in the first zone 1022 of knitted component 1000. Thus, second skin layer 1700 can be absent from the more elastic second zone 1024 of knitted component 1000.

[0145] In some embodiments, first skin layer 1600 and second skin layer 1700 can be disposed in and can partially form substantially smooth area 540 of upper 520 as shown in FIG. 15. Thus, first skin layer 1600 and second skin layer 1700 can provide support to smooth area 540 of upper 520.

[0146] Furthermore, in some embodiments, first skin layer 1600 and second skin layer 1700 can be disposed generally in textured area 550 of upper 520. In some embodiments, first skin layer 1600 and/or second skin layer 1700 can be layered over and attached to knitted component 1000 across textured area 550 as shown in FIG. 15.

[0147] In some embodiments, first skin layer 1600 and/or second skin layer 1700 can increase the stiffness of the upper 520 for retaining the texture of textured area 550. Stated

differently, first skin layer 1600 and/or second skin layer 1700 can resist bending and deformation from the wavy or bumpy configuration of textured area 550. However, first skin layer 1600 and second skin layer 1700 can be resilient and bendable to allow some resilient deformation of textured area 550.

[0148] Moreover, in some embodiments, one or more portions of first skin layer 1600 and/or second skin layer 1700 can be attached to knitted component, and other portions can be detached from knitted component 1000. For example, as shown in FIG. 19, first skin layer 1600 can include one or more attached portions 1608 and one or more detached portions 1610. Attached portions 1608 can be layered and attached to knitted component 1000 while detached portions 1610 can be detached from knitted component 1000. Specifically, in some embodiments represented in FIG. 19, attached portions 1608 can be included at smooth area 540 of upper 520, and detached portions 1610 can be included at textured area 550 of upper 520. Thus, detached portions 1610 can “float” relative to textured area 550, and attached portions 1608 can secure first skin layer 1600 to knit element 1000. Also, in some embodiments, detached area of first skin layer 1600 can at least partially lie smoothly against the wearer’s foot while textured area 550 can rise and fall relative to the wearer’s foot.

[0149] In some embodiments, the detached portions 1610 of first skin layer 1600 can be located proximate to tensile elements 1003 of knitted component 1000. For example, in some embodiments represented in FIG. 19, tensile element 1003 can include at least one internal segment 1040 that is inlaid or otherwise attached to knit element 1002. Tensile element 1003 can also include at least one external segment 1042 that is detached and disposed external from knit element 1002. For example, as shown in FIG. 19, tensile element 1003 can include first segment 1043, which is inlaid within knit element 1002 proximate peripheral edge 1010, a second segment 1045, which is inlaid within knit element 1002 proximate throat portion 1119, and a third segment 1047, which extends between first segment 1043 and second segment 1045. In some embodiments, first segment 1043 and second segment 1045 can be attached to knit element 1002 within smooth areas 540, and third segment 1047 can extend across textured area 550 of knitted component 1000. Furthermore, in some embodiments, third segment 1047 of tensile element 1003 can extend out from front surface 1008 of knit element 1002 to extend across textured area 550.

[0150] Also, as shown in FIG. 19, detached portion 1610 of first skin layer 1600 can overlay detached segment 1042 of tensile element 1003, and both can “float” over textured area 550, proximate front surface 1008 of knit element 1002. In some embodiments, this floating arrangement of skin layer 1600 and tensile strand 1003 can allow textured area 550 to flex and deform readily without being overly constrained by tensile element 1003 and first skin layer 1600.

[0151] FIG. 20 illustrates another embodiment, in which a majority of tensile element 1003 is inlaid internally within knitted component 1000. For example, tensile element 1003 can be inlaid within knitted component 1000 to extend along both smooth area 540 and textured area 550. Also, a majority of first skin layer 1600 can overlay and attach to portions of knitted component 1002 where the tensile element 1003 is inlaid.

[0152] Referring now to FIGS. 21-23, additional embodiments are illustrated. As shown, the article of footwear 5100 can be similar to one or more embodiments disclosed herein except as noted below.

[0153] In some embodiments, footwear 5100 can include a sole structure 5110 and an upper 5120. The upper 5120 can include a smooth area 5140 proximate the heel region 5114, and the upper 5120 can include a textured area 5150 generally in the forefoot region 5111 and midfoot region 5112. In some embodiments, the textured area 5150 can extend from the medial side 5115, across the forefoot region 5111, and onto the lateral side 5117.

[0154] Additionally, the upper 5120 can include multiple components that are overlapped and layered over each other. One component can provide textured structures, and the other component can be layered over at least some of the textured structures. Also, in some embodiments, the other component can include apertures that expose at least some of the textured structures.

[0155] Specifically, as shown in FIG. 23, the upper 5120 can include a textile component, such as a knitted component 5000. In some embodiments, the knitted component 5000 can be mesh-like. The knitted component 5000 can include a plurality of projection structures 5151 of the type discussed above. Also, the upper 5120 can include a skin layer 5700. In some embodiments, the skin layer 5700 can be layered over the outside of the knitted component 5000. As such, the skin layer 5700 can at least partially define the outer surface 5125 of the upper 5120. However, in additional embodiments, it will be appreciated that the skin layer 5700 can be layered over the inside of the knitted component 5000 so as to define the inner surface 5123 (i.e., similar to a liner).

[0156] As shown in FIGS. 21-23, the skin layer 5700 can include a plurality of openings 5704. In some embodiments, the openings 5704 can be disposed in a predetermined position relative to the pattern of projection structures 5151. For example, the openings 5704 can be positioned to receive preselected projection structures 5151 of the knitted component 5000. Stated differently, some of the projection structures 5151 can project through the openings 5704 and can be exposed from the skin layer 5700. As such, the projection structures 5151 extending through the openings 5704 can be referred to as exposed projection structures 5099. Other projection structures 5151 can be covered over by the skin layer 5700. Those projection structures 5151 can be referred to as covered projection structures 5098. (The covered projection structures 5098 are shown in FIGS. 21 and 22 with broken lines.) Accordingly, the knitted component 5000 can define the exposed projection structures 5099 whereas the knitted component 5000 and the skin layer 5700 can cooperate to define the covered projection structures 5099.

[0157] In some embodiments, the exposed projection structures 5099 and the covered projection structures 5098 can have different characteristics. For example, the exposed projection structures 5099 can have a higher coefficient of friction than the covered projection structures 5098. Also, in some embodiments, the exposed projection structures 5099 can exhibit a higher degree of flexibility and resilience than the covered projection structures 5098. Moreover, in some embodiments, the larger projection structures 5151 can be exposed projection structures 5099, and the smaller projection structures 5151 can be covered projection structures 5098.

[0158] Thus, the exposed projection structures 5099 and the covered projection structures 5098 can each be disposed in predetermined areas of the upper 5120. For example, in the case of a soccer shoe (i.e., soccer boot), the exposed projection structures 5099 can be disposed in areas of the upper 5120 that provide a high degree of ball control, ball feel, etc. In contrast, the covered projection structures 5098 can be disposed in areas of the upper 5120 that provide a lower degree of ball control, ball feel, etc.

[0159] Resilient Deformation of Upper

[0160] In some embodiments, textured area 550 of upper 520 can resiliently deform to provide the wearer with certain benefits. For example, in some embodiments, textured area 550 can deform and flatten out when textured area 550 impacts a ball or other object. Then, textured area 550 can resiliently recover back to the more textured state. Accordingly, this resilient deformation can dampen and dissipate the impact energy. Thus, the wearer may be able to more reliably trap a soccer ball, the wearer may be better able to direct the ball when kicking and passing, and/or the textured area 550 can provide increased tactile feel of the ball when controlling the ball.

[0161] This resilient deformation is illustrated in FIGS. 24-26. FIG. 24 shows the article of footwear 500 and a ball 599. The ball 599 is shown moving toward footwear 500. FIG. 25 corresponds with FIG. 24, but upper 520 is shown in section view. As shown, textured area 550 is shown in its textured configuration, wherein the projection structures 551 project outward from cavity 522 within upper 520. Also, in embodiments in which textured area 550 includes recess structures, those recess structures can be recessed into cavity 522 when textured area 550 is in the textured configuration of FIG. 25. The textured configuration can also be referred to as a first position, an undeformed position, or a neutral position of textured area 550.

[0162] As shown in FIG. 26, the impact with ball 599 can cause textured area 550 to flatten out or otherwise deform. The deformed configuration represented in FIG. 26 can be referred to as a flattened configuration, a second position, or a deformed position of textured area 550. In some embodiments, projection structures 551 (and any recess structures) of textured area 550 can compress and flatten between the ball 599 and the wearer's foot when in this position.

[0163] This deformation can dampen the energy of impact in some embodiments. Also, this deformation can cause upper 520 to shift slightly against the wearer's foot, thereby providing tactile "feel" of the ball 599 to the wearer.

[0164] When the load is reduced, the textured area 550 can resiliently recover from the deformed configuration of FIG. 26 back to the textured configuration of FIG. 25. Stated differently, the textured area 550 can be biased toward the textured configuration represented, for example, in FIG. 25.

[0165] Moreover, in some embodiments, the gradient arrangement of the textured area 550 can provide certain benefits to the wearer. For example, the gradient can allow the upper 520 to deform in a desirable manner. More specifically, the tallest projection structures 551 can be highly deformable, and surrounding gradient of projection structures 551 can distribute forces through the textured area 550 to inhibit bunching or wrinkling of upper 520 during deformation.

[0166] Furthermore, in some embodiments, the gradient of projection structures 551 can, for example, be arranged for directing or otherwise controlling the ball 599. For example,

an imaginary tangent line **1804** is included in FIG. **25**, which is tangent to multiple adjacent projection structures **551**. As shown, the tangent line **1804** is disposed at an angle **1802** relative to the ground surface **1800**. This angle **1802** can be predetermined. For example, in some embodiments, the angle **1802** can be selected such that projection structures **551** are better able to lift the ball **599** from the ground **1800** when kicking and/or passing.

[0167] Method of Manufacturing Upper and Article of Footwear

[0168] A variety of processes may be utilized to form the upper and the article of footwear of the present disclosure. For example, in some embodiments, the upper can be formed at least partially via a knitting process as discussed above. Also, in some embodiments, a skin layer or other object can be incorporated within the upper as discussed above. Moreover, in some embodiments, heat and/or pressure can be applied for forming features of the upper. For example, heat and/or pressure can be applied to form the textured area of the upper.

[0169] Additionally, in some embodiments, heat can be applied to thermally bond the skin layer(s) to the knitted component of the upper. The term “thermal bond” or variants thereof is defined as the bond, link, or structure that joins two elements through a process that involves a softening or melting of a polymeric material within at least one of the elements such that the materials of the elements are secured to each other when cooled. As examples, thermal bonding may involve: (a) the melting or softening of skin layers **1600**, **1700** such that those materials intermingle with materials of knitted component **1000** and are secured together when cooled; and (b) the melting or softening of skin layers **1600**, **1700** such that the those materials extend into or infiltrates the structure of knitted component **1000** (e.g., extends around or bonds with filaments or fibers in knitted component **1000** to secure the elements together when cooled). Additionally, thermal bonding does not generally involve the use of stitching or adhesives, but involves directly bonding elements to each other with heat. In some situations, however, stitching or adhesives may be utilized to supplement the thermal bond or the joining of elements through thermal bonding.

[0170] In additional embodiments, heat and/or pressure can be applied using a molding apparatus, a press, an embossing apparatus, a thermoforming apparatus, or other machine. In some embodiments, the upper can be manufactured according to the U.S. patent application Ser. No. _____, entitled _____, which was co-filed with the present application on _____ (Attorney Docket No. 51-4776), the disclosure of which is incorporated by reference in its entirety.

[0171] While various embodiments of the present disclosure have been described, the description is intended to be exemplary, rather than limiting and it will be apparent to those of ordinary skill in the art that many more embodiments and implementations are possible that are within the scope of the present disclosure. Accordingly, the present disclosure is not to be restricted except in light of the attached claims and their equivalents. Also, various modifications and changes may be made within the scope of the attached claims. Moreover, as used in the claims “any of” when referencing the previous claims is intended to mean (i) any one claim, or (ii) any combination of two or more claims referenced.

1. An article of footwear comprising:
 - a sole structure, and
 - an upper that is attached to the sole structure, the upper defining a cavity that is configured to receive a foot of a wearer;
 - the upper at least partially defined by a textile;
 - the textile including a first area that is substantially smooth, the first area defining a reference boundary that conforms to the cavity;
 - the textile including a second area, the second area including a plurality of projection structures, the plurality of projection structures comprising portions of the textile that project away from the reference boundary and outwardly from the cavity, each of the plurality of projection structures having a height measured from the reference boundary, wherein at least one of the plurality of projection structures differs in height from at least one other of the plurality of projection structures;
 - the second area further including a plurality of recess structures that recess away from the reference boundary and inwardly toward the cavity, and
 - the plurality of projection structures and the plurality of recess structures being in an alternating arrangement across the second area of the textile.
2. The article of footwear of claim 1, wherein the plurality of projection structures are arranged in a gradient pattern, and wherein the heights of the projection structures vary gradually from projection structure to adjacent projection structure across the gradient pattern.
3. The article of footwear of claim 1, wherein the textile is a knitted component formed of unitary knit construction.
4. The article of footwear of claim 1, wherein the textile is a woven component.
5. The article of footwear of claim 1, wherein at least one of the plurality of projection structures is elastic and deformable between a first position and a second position,
 - wherein the at least one projection structure, in the first position, projects away from the reference boundary at a first height;
 - wherein the at least one projection structure, in the second position, projects away from the reference boundary at a second height;
 - wherein the first height is greater than the second height; and
 - wherein the at least one projection structure is resilient and biased toward the first position.
6. The article of footwear of claim 1, wherein the textile includes a first surface facing the cavity and a second surface facing away from the cavity; and
 - further comprising a skin layer that is layered on one of the inner surface and the outer surface.
7. The article of footwear of claim 6, wherein the textile includes a first zone and a second zone, wherein the second zone has a greater stretching elasticity than the first zone;
 - wherein the skin layer is layered on the first zone; and
 - wherein the skin layer is absent from the second zone.
8. The article of footwear of claim 6, wherein the skin layer includes a plurality of openings.
9. The article of footwear of claim 8, wherein at least one of the plurality of projection structures projects through at least one of the plurality of openings.

10. The article of footwear of claim 9, wherein the at least one of the plurality of projection structures is an exposed projection structure; and

wherein another of the plurality of projection structures is covered by the skin layer.

11. The article of footwear of claim 6, wherein the skin layer is a first skin layer layered on the first surface of the textile; and

further comprising a second skin layer layered on the second surface of the textile.

12. The article of footwear of claim 1, wherein the textile is a knitted component formed of unitary knit construction; wherein the knitted component includes a knit element and a tensile element;

wherein the knit element includes the plurality of projection structures and the plurality of recess structures; and wherein the tensile element is at least partially inlaid within the knit element.

13. The article of footwear of claim 12, wherein the tensile element is inlaid within at least one of the plurality of projection structures and within at least one of the plurality of recess structures of the knit element.

14. The article of footwear of claim 12, wherein the tensile element includes a first segment, a second segment, and a third segment that is disposed between the first and second segments;

wherein the first segment and the second segment are inlaid within the knit element;

wherein the third segment is disposed outside the knit element; and

wherein the third segment extends at least partially across the second area of the knit element.

15. The article of footwear of claim 14, wherein the second area is disposed between a throat of the upper and a sole attachment area of the upper;

wherein the first segment is disposed proximate the throat;

wherein the second segment is disposed proximate the sole attachment area; and

wherein the third segment extends between the throat and the sole attachment area.

16. The article of footwear of claim 1, wherein the first area is disposed generally in a heel region of the upper; and

wherein the second area is disposed in at least one of a midfoot region of the upper and a forefoot region of the upper.

17. The article of footwear of claim 16, wherein the second area extends across the forefoot region between the medial side and the lateral side;

wherein the plurality of projection structures are arranged in a gradient pattern that extends across the forefoot region between the medial and lateral side; and

wherein the heights of the projection structures vary gradually from projection structure to adjacent projection structure within the gradient pattern.

18. The article of footwear of claim 16, wherein the upper defines a longitudinal direction extending between the heel region and the forefoot region;

wherein the plurality of projection structures are arranged in a gradient pattern that extends in the longitudinal direction; and

wherein the heights of the projection structures within the gradient pattern vary gradually from projection structure to adjacent projection structure along the longitudinal direction.

19. The article of footwear of claim 16, wherein the upper defines a vertical direction extending between a sole attachment area of the upper and a throat area of the upper;

wherein the plurality of projection structures are arranged in a gradient pattern that extends in the vertical direction; and

wherein the heights of the projection structures within the gradient pattern vary gradually from projection structure to adjacent projection structure along the vertical direction.

20. The article of footwear of claim 1, wherein at least one of the plurality of projection structures is substantially rounded.

21. The article of footwear of claim 1, wherein at least one of the plurality of projection structures includes a substantially flat surface.

22. The article of footwear of claim 1, wherein the plurality of projection structures are arranged in a gradient pattern; and

wherein the heights of the projection structures vary gradually from projection structure to adjacent projection structure within the gradient pattern;

wherein the textile includes a visual indicium that varies along the upper; and

wherein the varying of the visual indicium and the varying of the heights of the projection structures correspond to each other.

23. The article of footwear of claim 1, wherein the textile includes a plurality of second areas.

24. An article of footwear comprising:

a sole structure; and

an upper that is attached to the sole structure, the upper defining a cavity that is configured to receive a foot of a wearer;

the upper at least partially defined by a knitted component that is formed of unitary knit construction;

the upper including a first area that is substantially smooth, the first area defining a reference boundary that substantially conforms to the cavity;

the upper including a second area that includes a plurality of projection structures that project away from the reference boundary and away from the cavity, the plurality of projection structures being at least partially defined by the knitted component;

at least one of the plurality of projection structures including a convex exterior surface and a concave interior surface, the convex exterior surface facing generally away from the cavity, the convex exterior surface facing opposite the concave interior surface, the concave interior surface being open to the cavity.

25. The article of footwear of claim 24, wherein the second area further comprises a plurality of recess structures that recess inwardly from the reference boundary, the plurality of recess structures being at least partially defined by the knitted component;

wherein the plurality of recess structures and the plurality of projection structures are disposed in an alternating arrangement.

26. The article of footwear of claim 24, wherein the plurality of projection structures project away from the reference boundary at varying heights, the heights varying gradually across the second area such that the plurality of projection structures are arranged in a gradient pattern.

27. The article of footwear of claim 24, wherein the upper includes a skin layer that is layered on the knitted component, the skin layer defining one of the convex exterior surface and the concave interior surface.

28. The article of footwear of claim 24, wherein the knitted component includes a knit element and a tensile element;

wherein the knit element substantially defines the plurality of projection structures; and

wherein the tensile element is at least partially inlaid within the knit element.

29. A knitted component formed of unitary knit construction and configured to at least partially form an upper, the upper configured to define a cavity that is configured to receive a foot, the upper configured to attach to a sole structure to form an article of footwear, the knitted component comprising:

a first area that is substantially smooth, the first area defining a reference boundary, the reference boundary configured to substantially conform to the cavity; and

a second area that includes a plurality of projection structures that each project away from the reference boundary at a respective height;

the plurality of projection structures arranged in a gradient pattern such that the respective heights gradually increase across the gradient pattern.

30. The knitted component of claim 29, wherein the knitted component further comprises:

a knit element that substantially defines the first area and the plurality of projection structures of the second area; and

a tensile element that is at least partially inlaid within the knit element.

31. The knitted component of claim 30, wherein the tensile element is inlaid within at least one of the plurality of projection structures.

32. The knitted component of claim 30, wherein the tensile element includes a first segment, a second segment, and a third segment;

wherein the first segment and the second segment are inlaid within the knit element;

wherein the third segment is disposed outside the knit element; and

wherein the third segment extends at least partially across the second area.

* * * * *