



US 20160206039A1

(19) **United States**

(12) **Patent Application Publication**

Cross et al.

(10) **Pub. No.: US 2016/0206039 A1**

(43) **Pub. Date: Jul. 21, 2016**

(54) **SOLE SYSTEM FOR AN ARTICLE OF FOOTWEAR INCORPORATING A KNITTED COMPONENT WITH A ONE-PIECE KNIT OUTSOLE**

D04B 1/22 (2006.01)

A43B 23/02 (2006.01)

(52) **U.S. Cl.**

CPC *A43B 13/02* (2013.01); *A43B 23/0245* (2013.01); *A43C 15/16* (2013.01); *D04B 1/22* (2013.01)

(71) Applicant: **NIKE, Inc.**, Beaverton, OR (US)

(72) Inventors: **Tory M. Cross**, Portland, OR (US);
Daniel A. Podhajny, Beaverton, OR (US)

(57) **ABSTRACT**

(21) Appl. No.: **14/598,406**

(22) Filed: **Jan. 16, 2015**

Publication Classification

(51) **Int. Cl.**

A43B 13/02 (2006.01)

A43C 15/16 (2006.01)

An article of footwear including a sole system, including an upper and the sole system. The sole system includes a knitted component incorporating a one-piece knit outsole. The knit outsole has a ground-facing side, a top side, and a ground-engaging cleat member protruding from the ground-facing side of the knit outsole. The upper is connected at its bottom to the top side of the knit outsole.

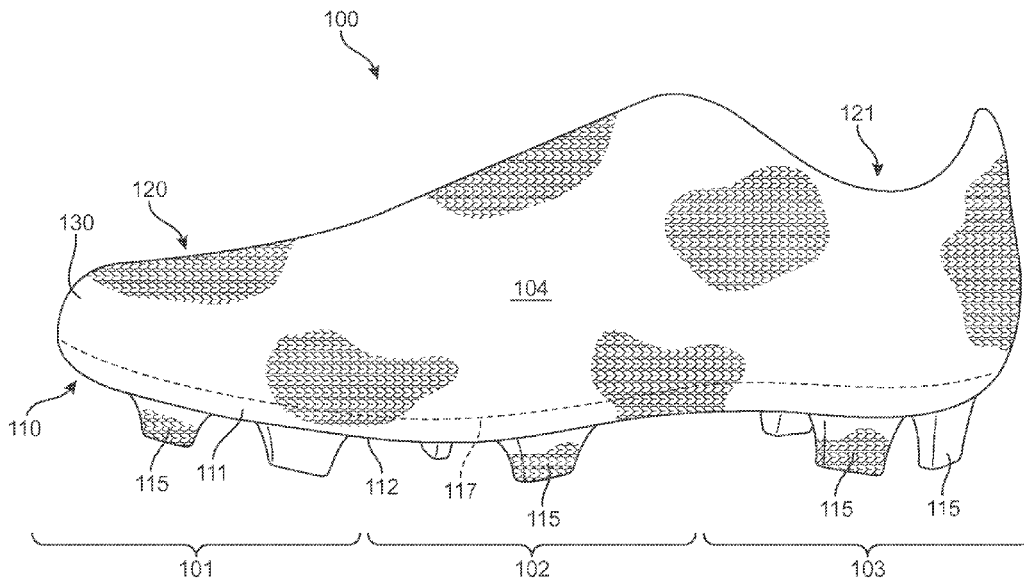

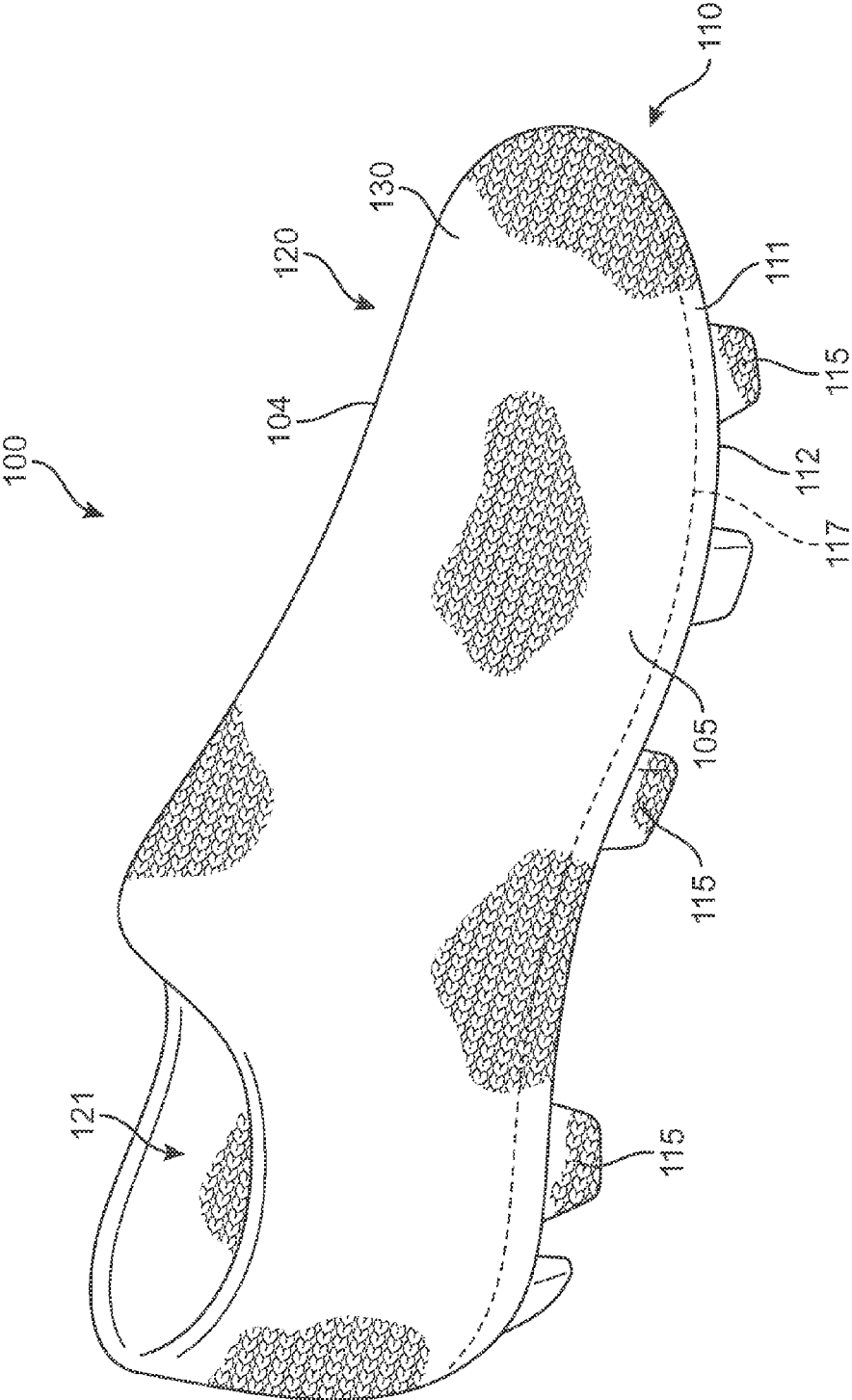

FIG. 1

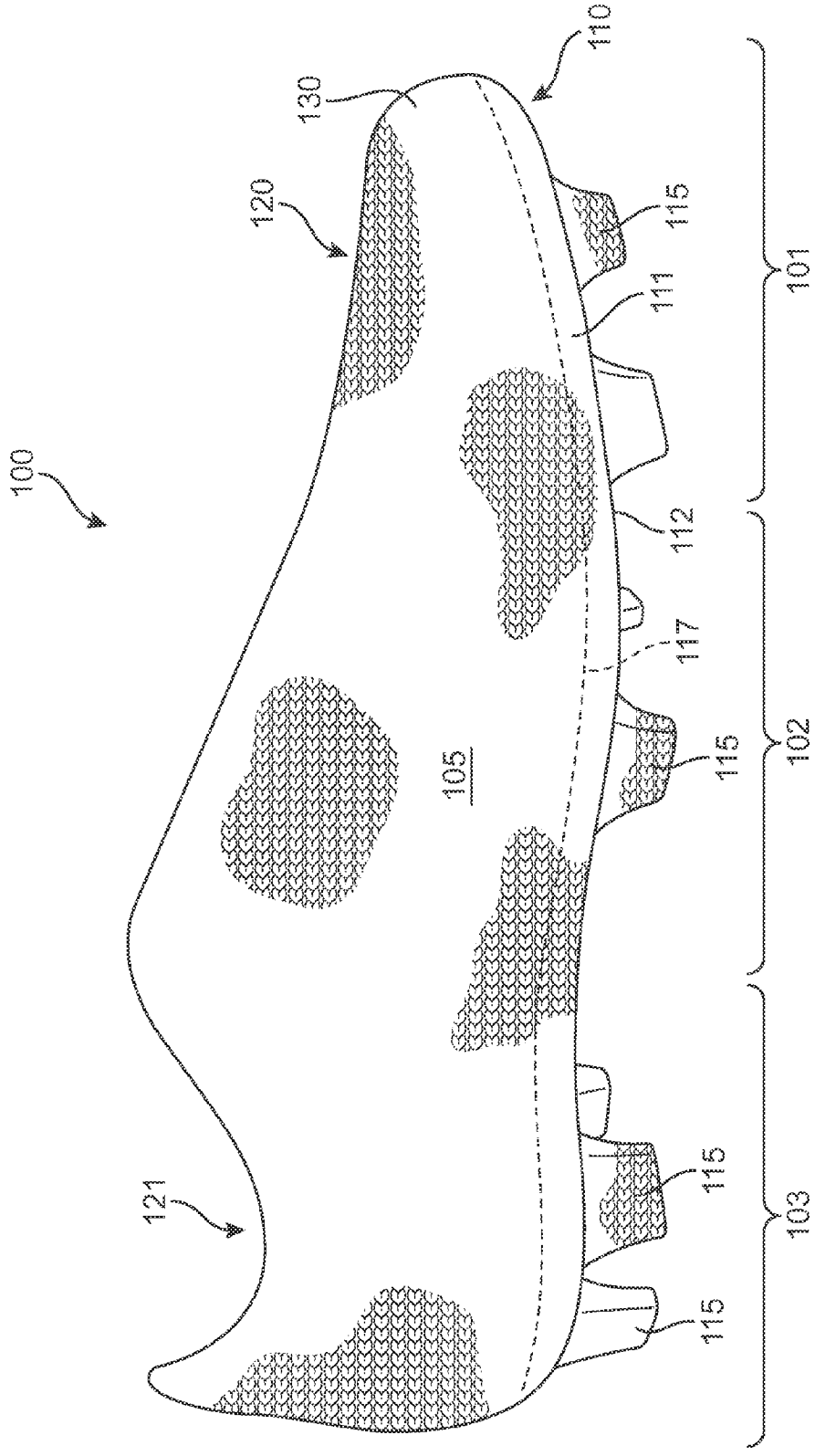

FIG. 2

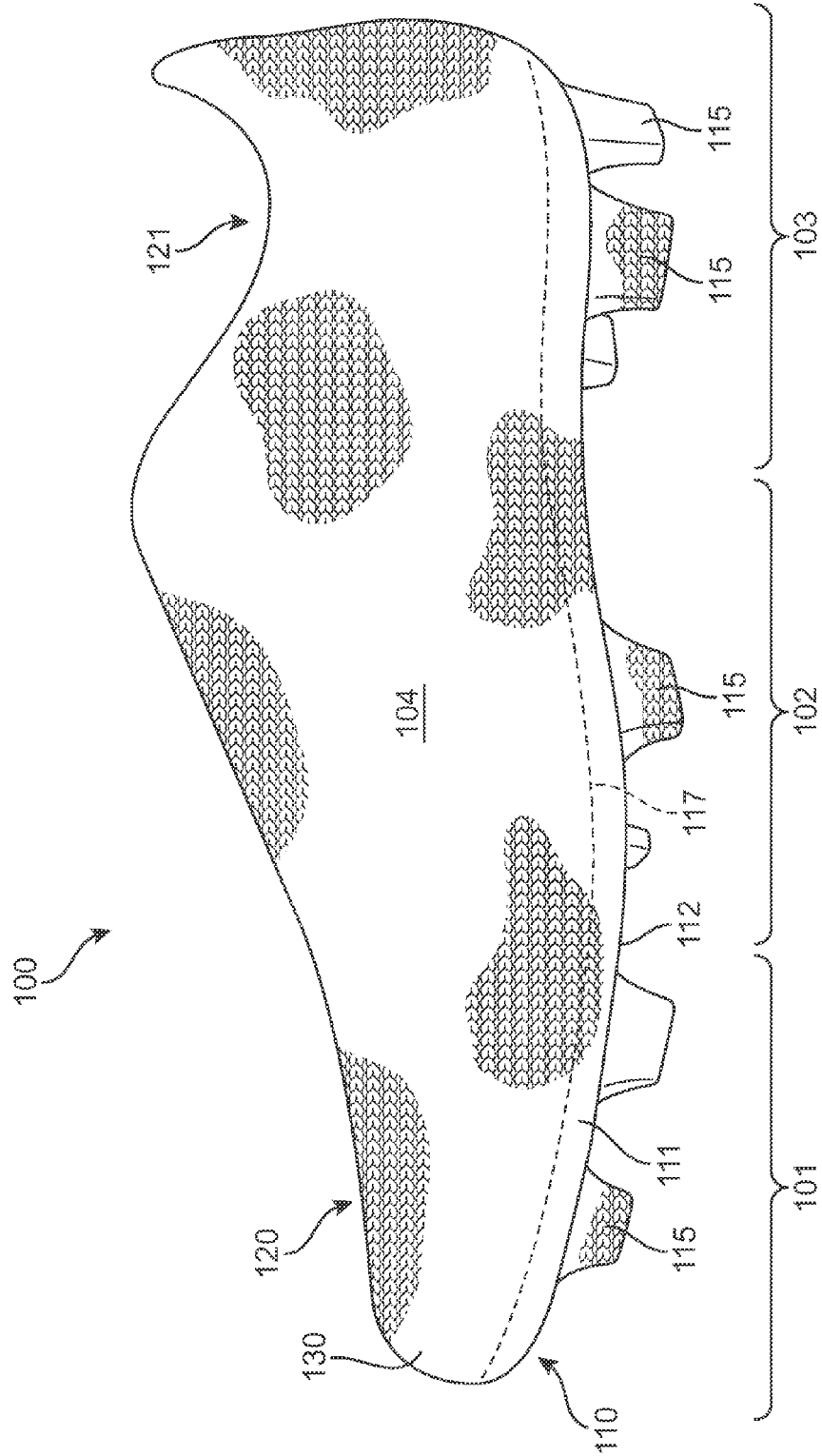

FIG. 3

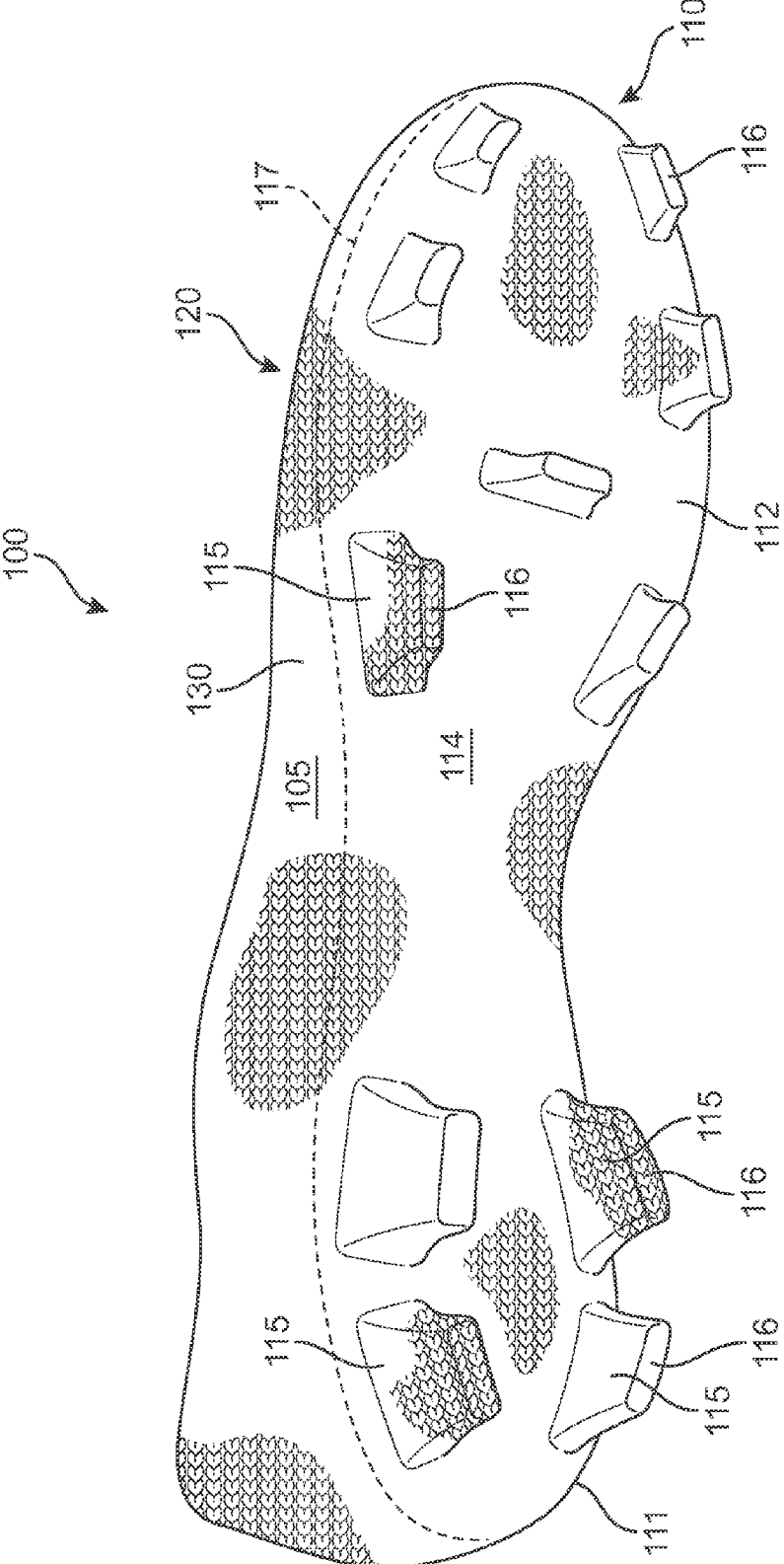

FIG. 4

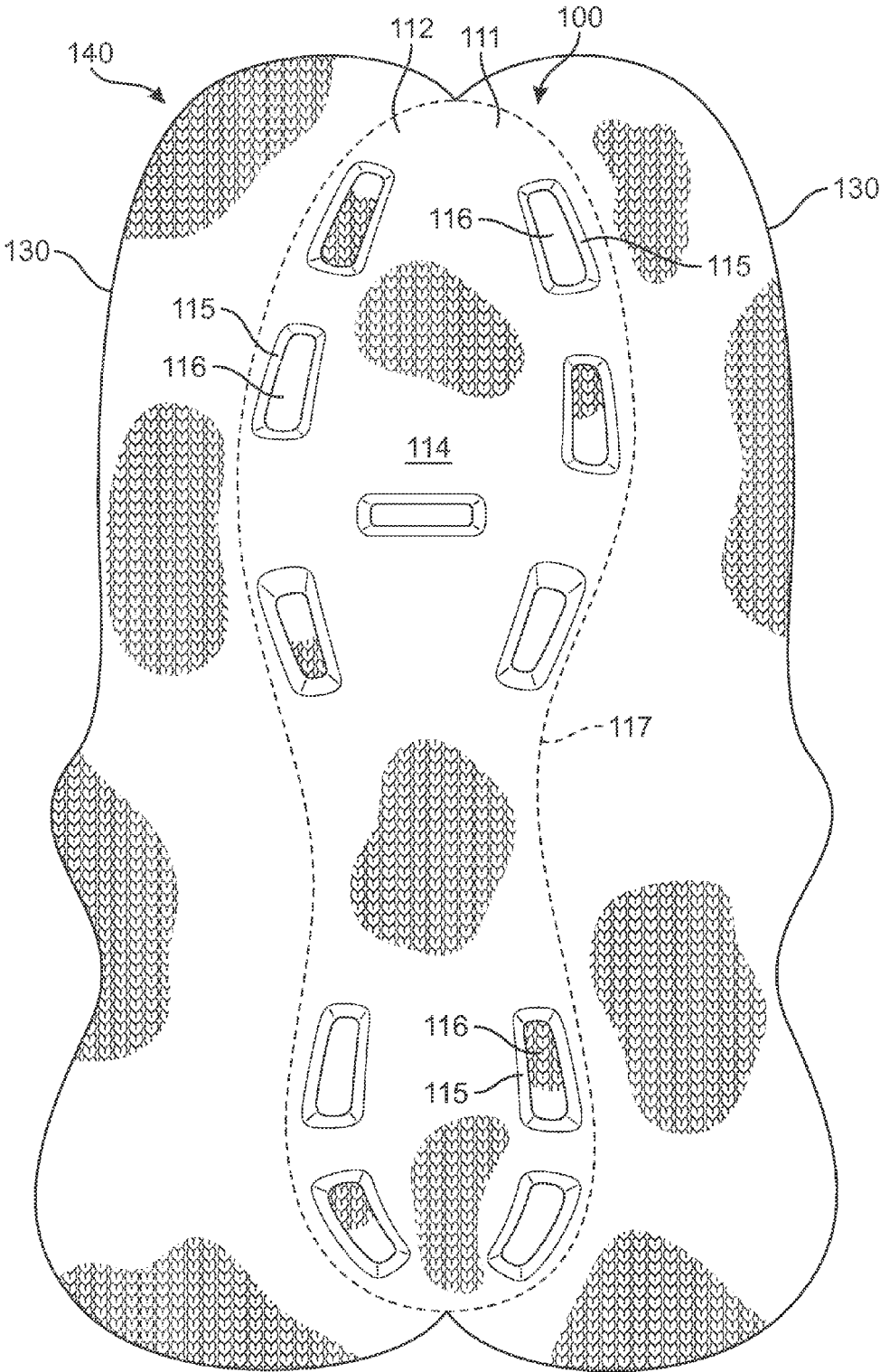

FIG. 5

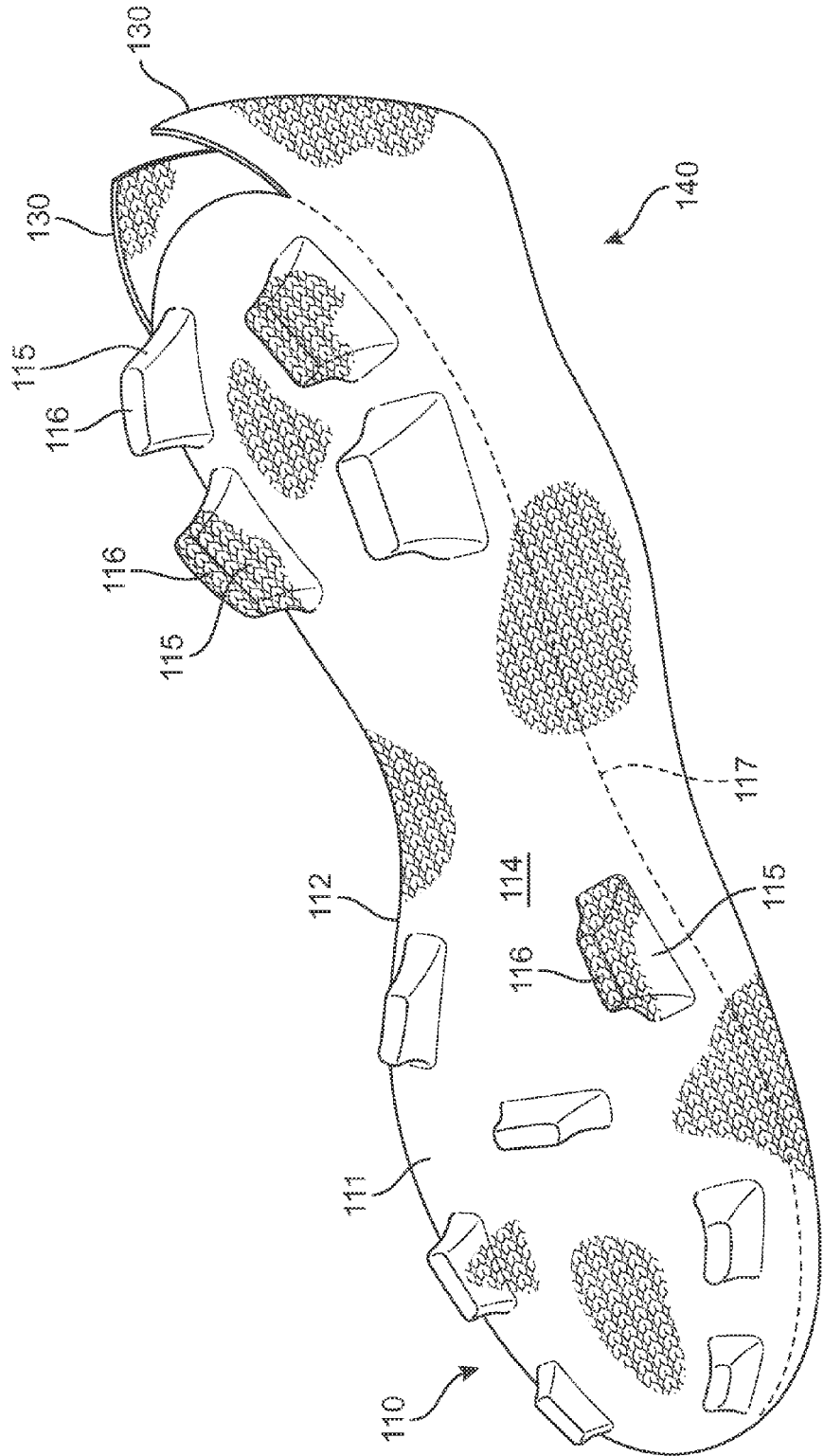

FIG. 6

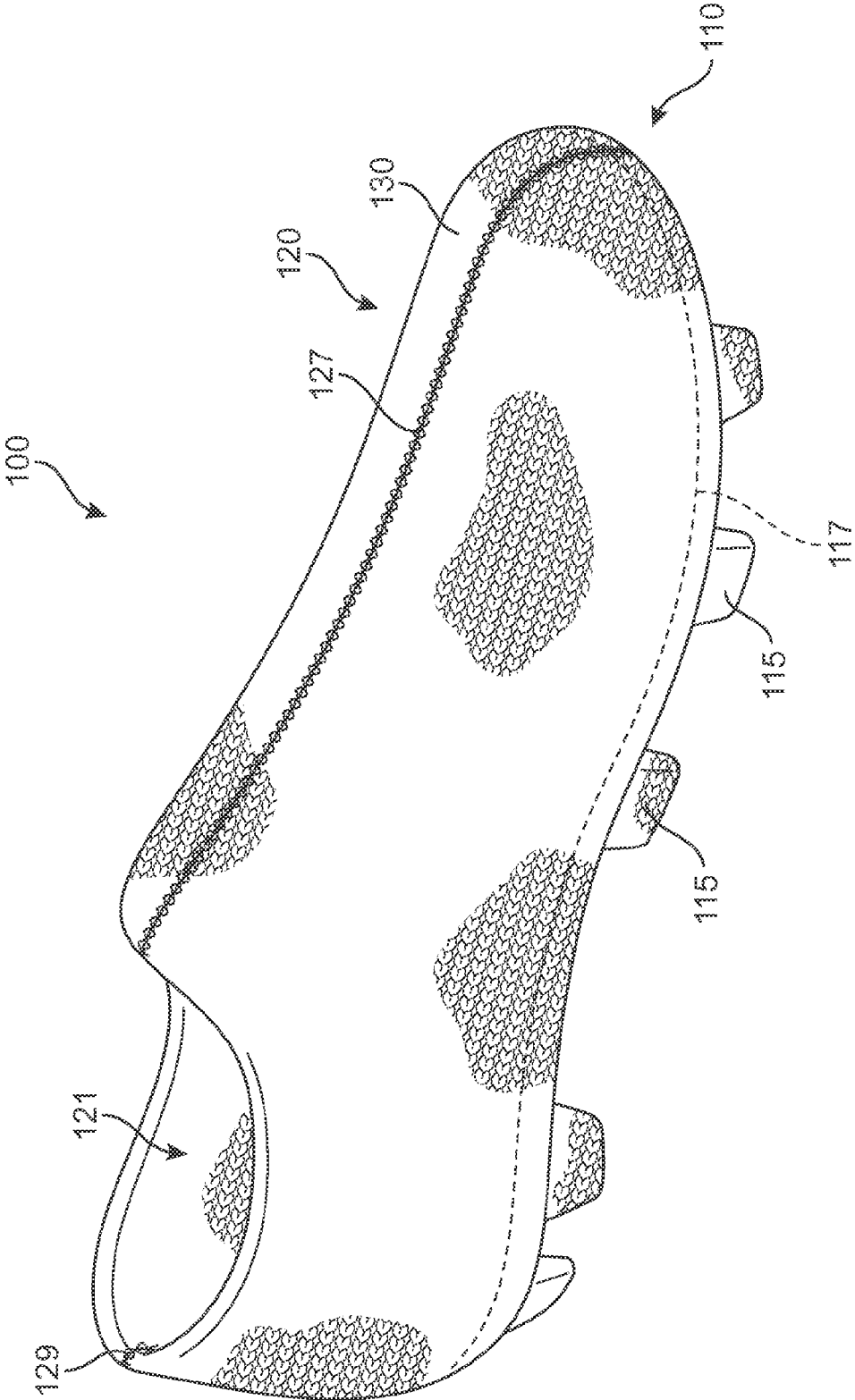

FIG. 7

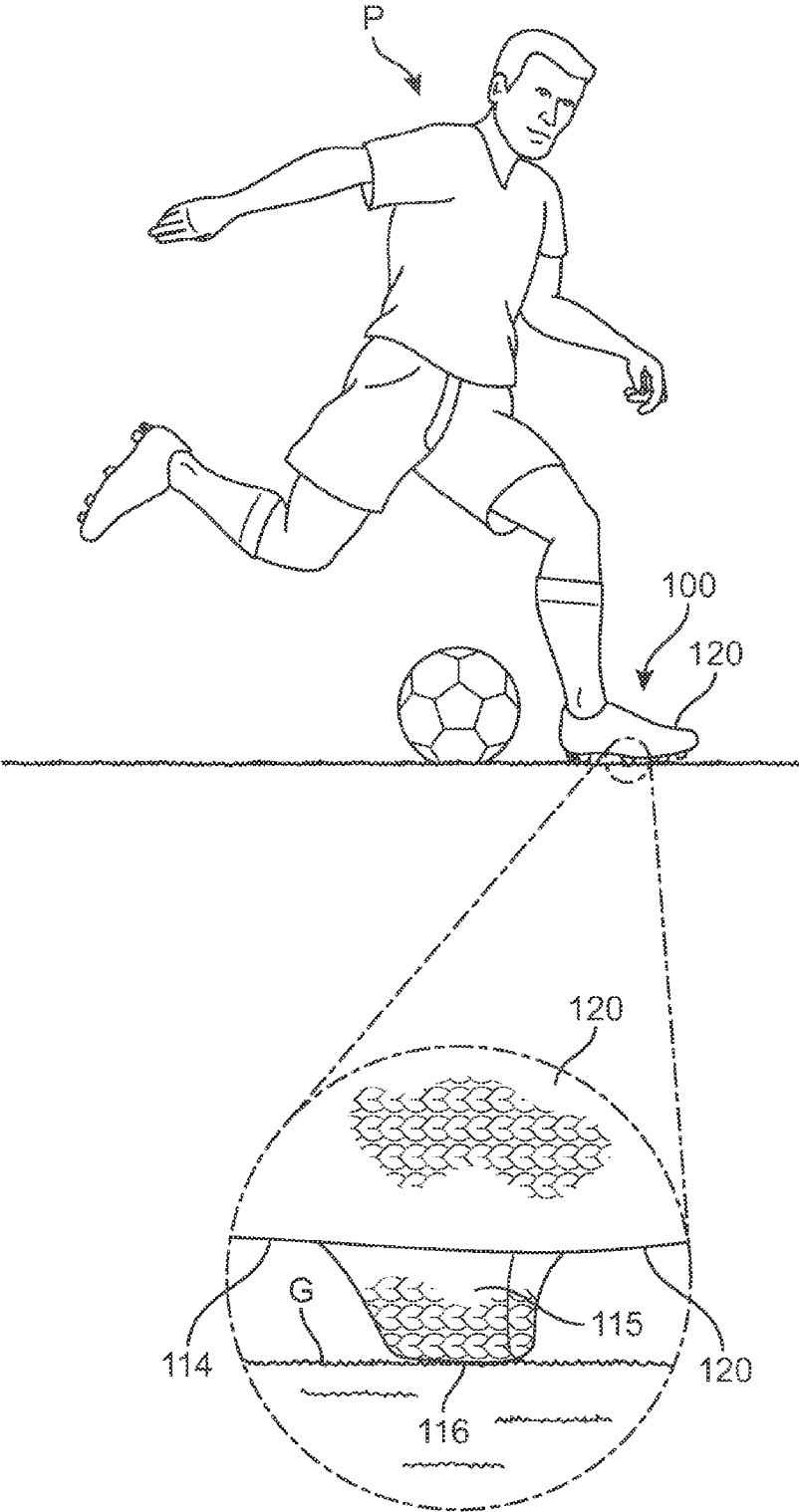

FIG. 8

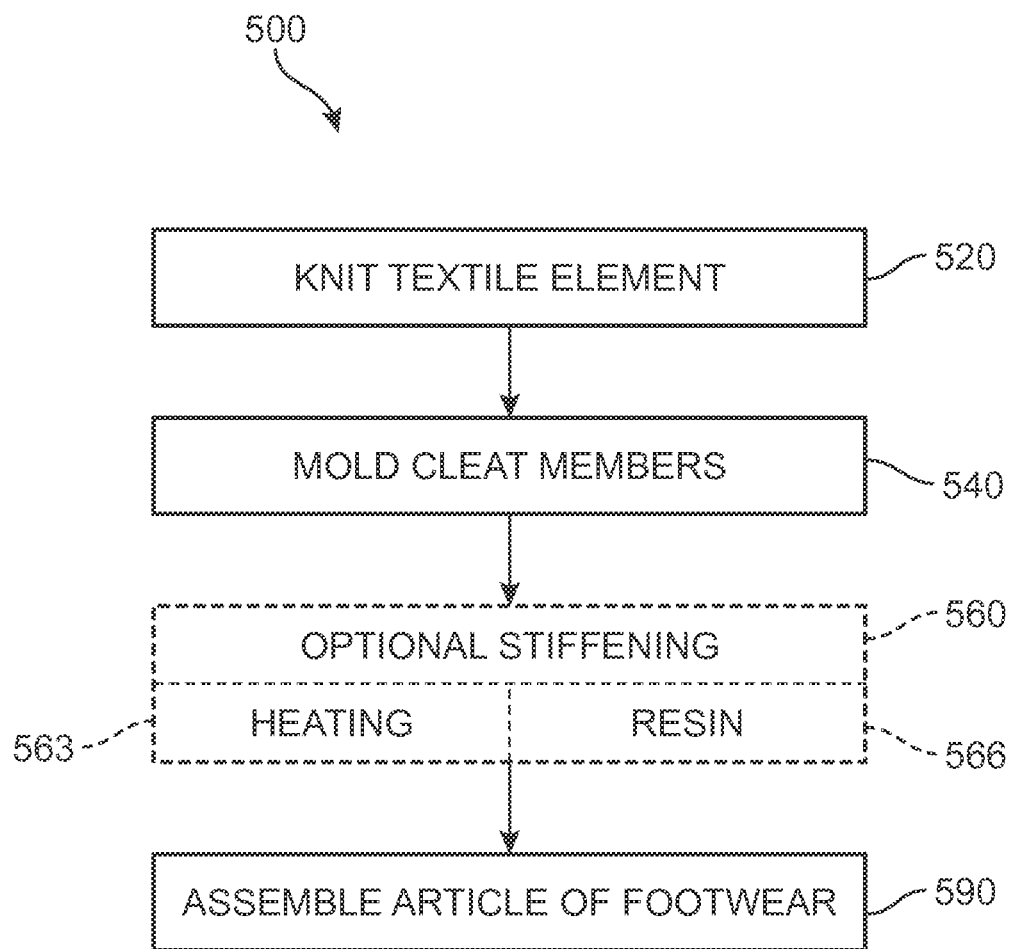

FIG. 9

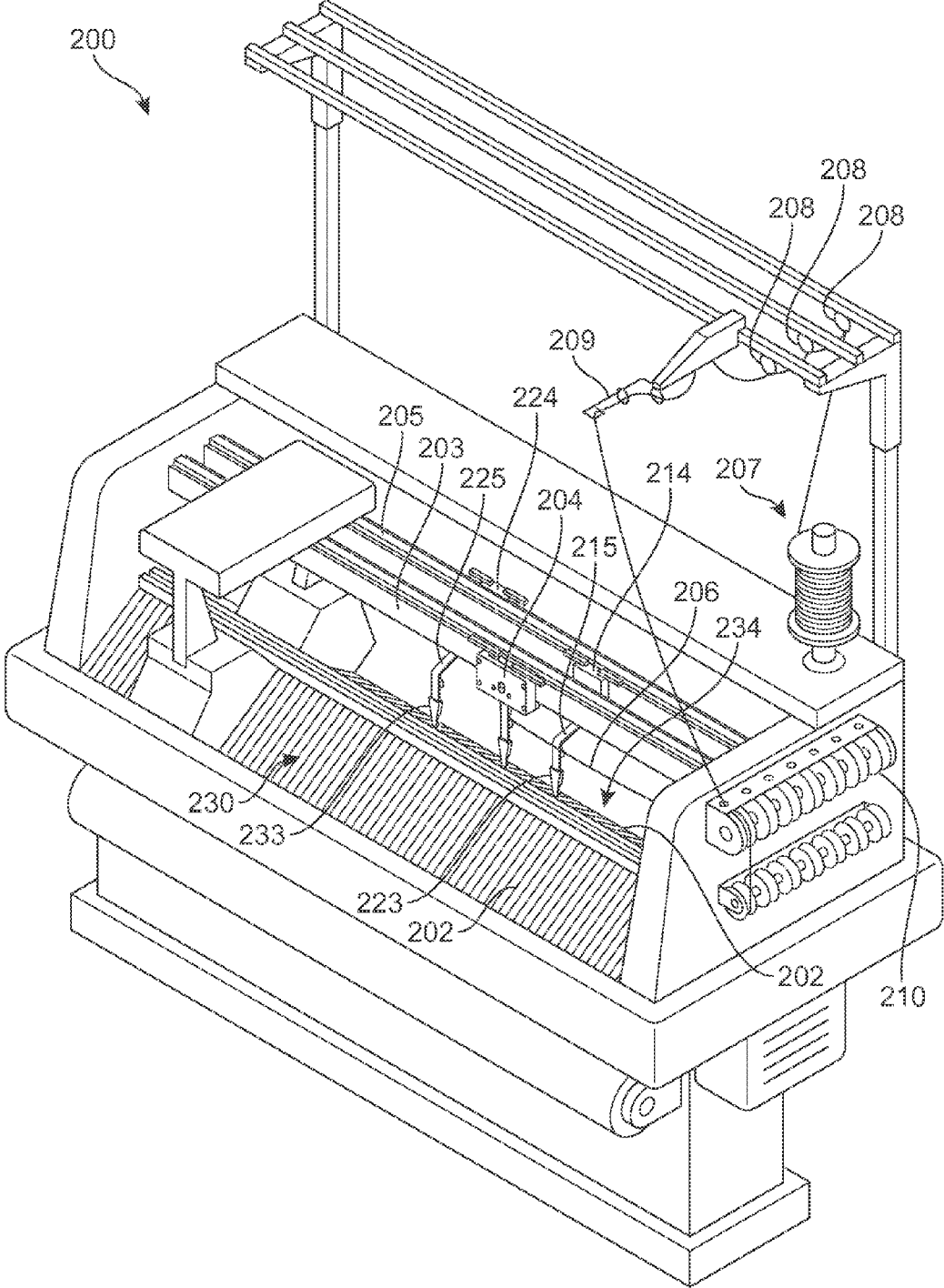

FIG. 10

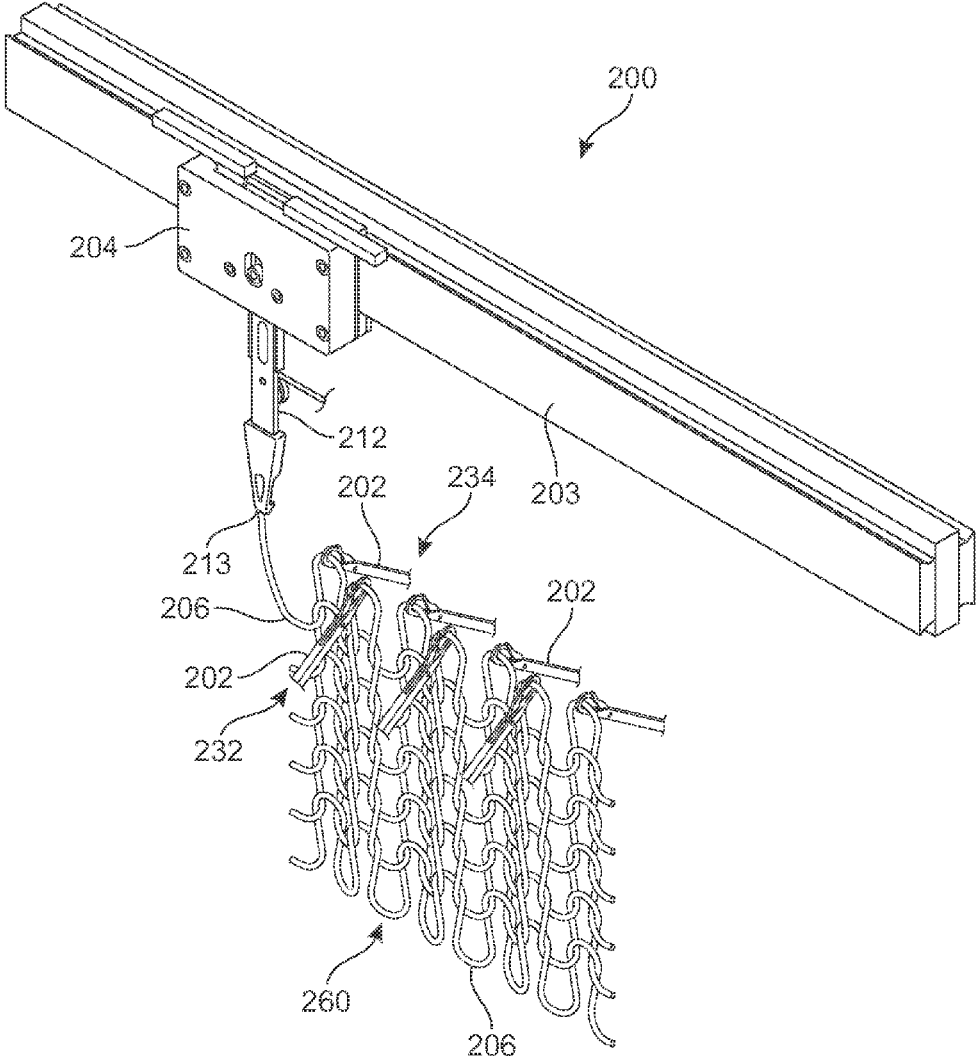

FIG. 11

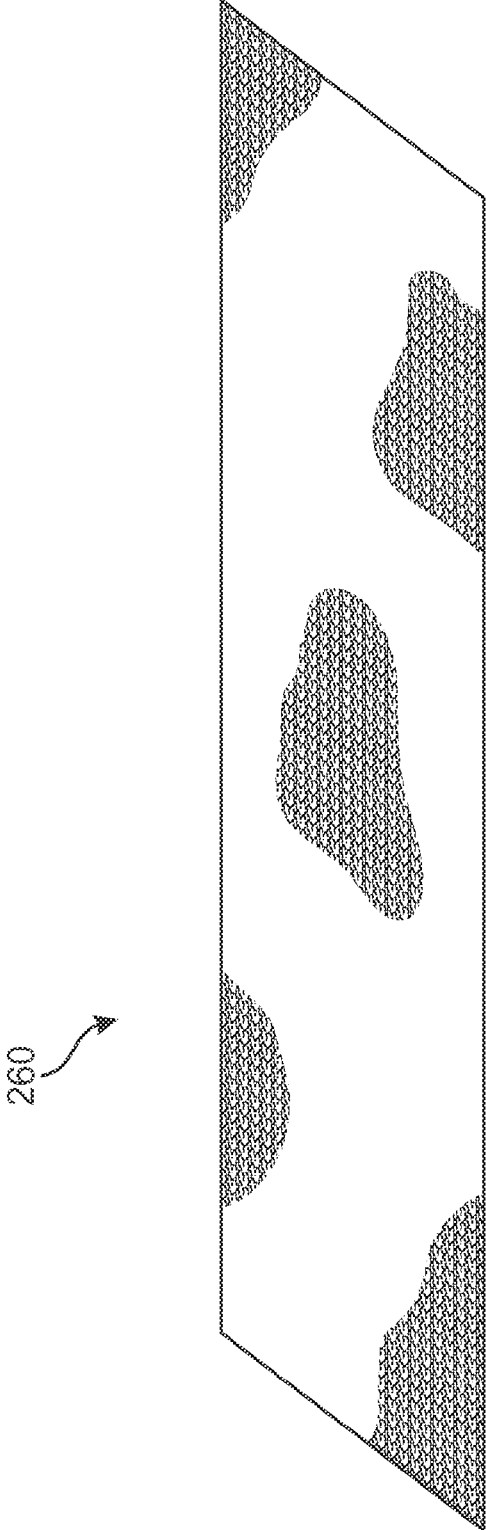

FIG. 12

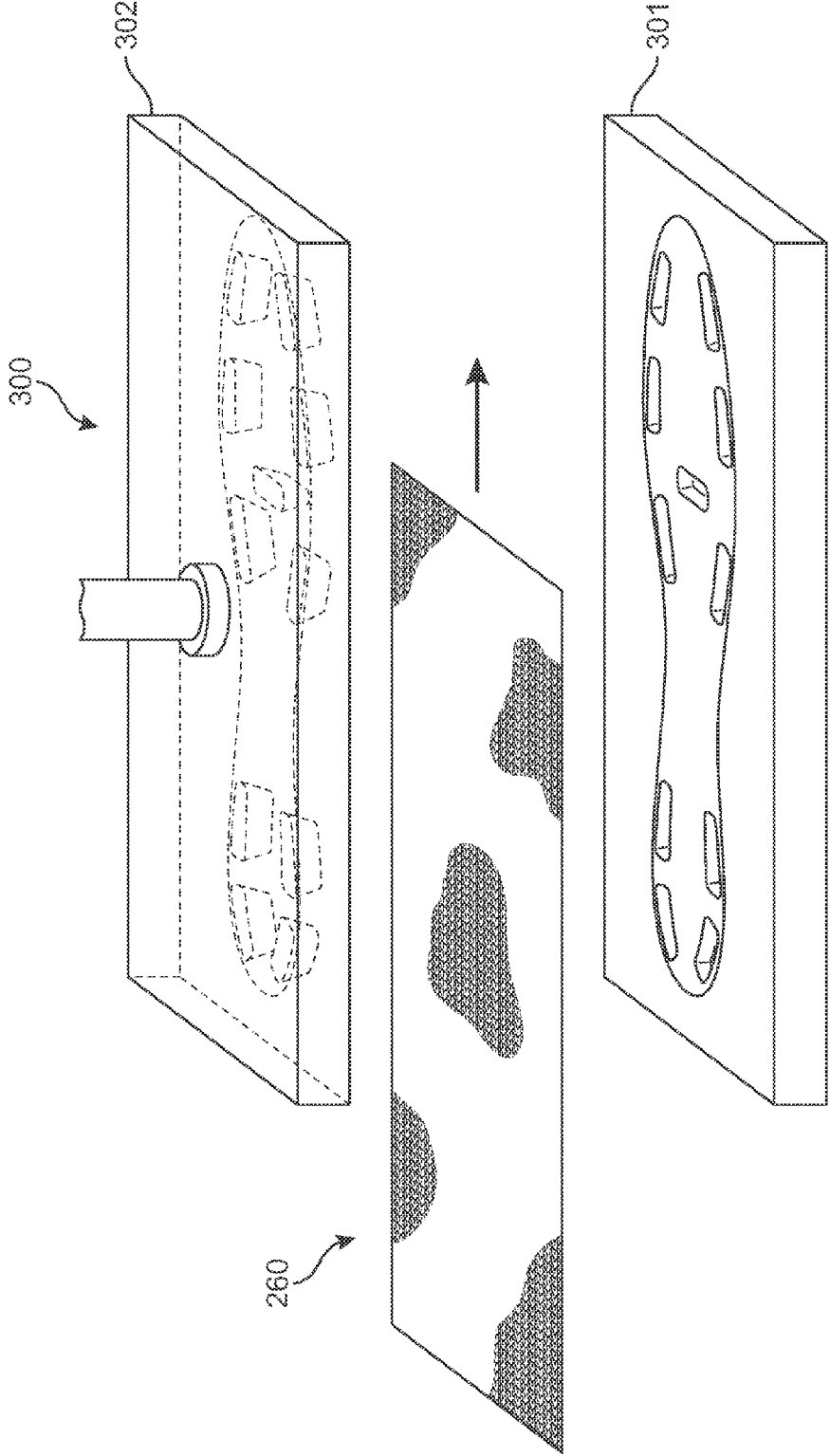

FIG. 13

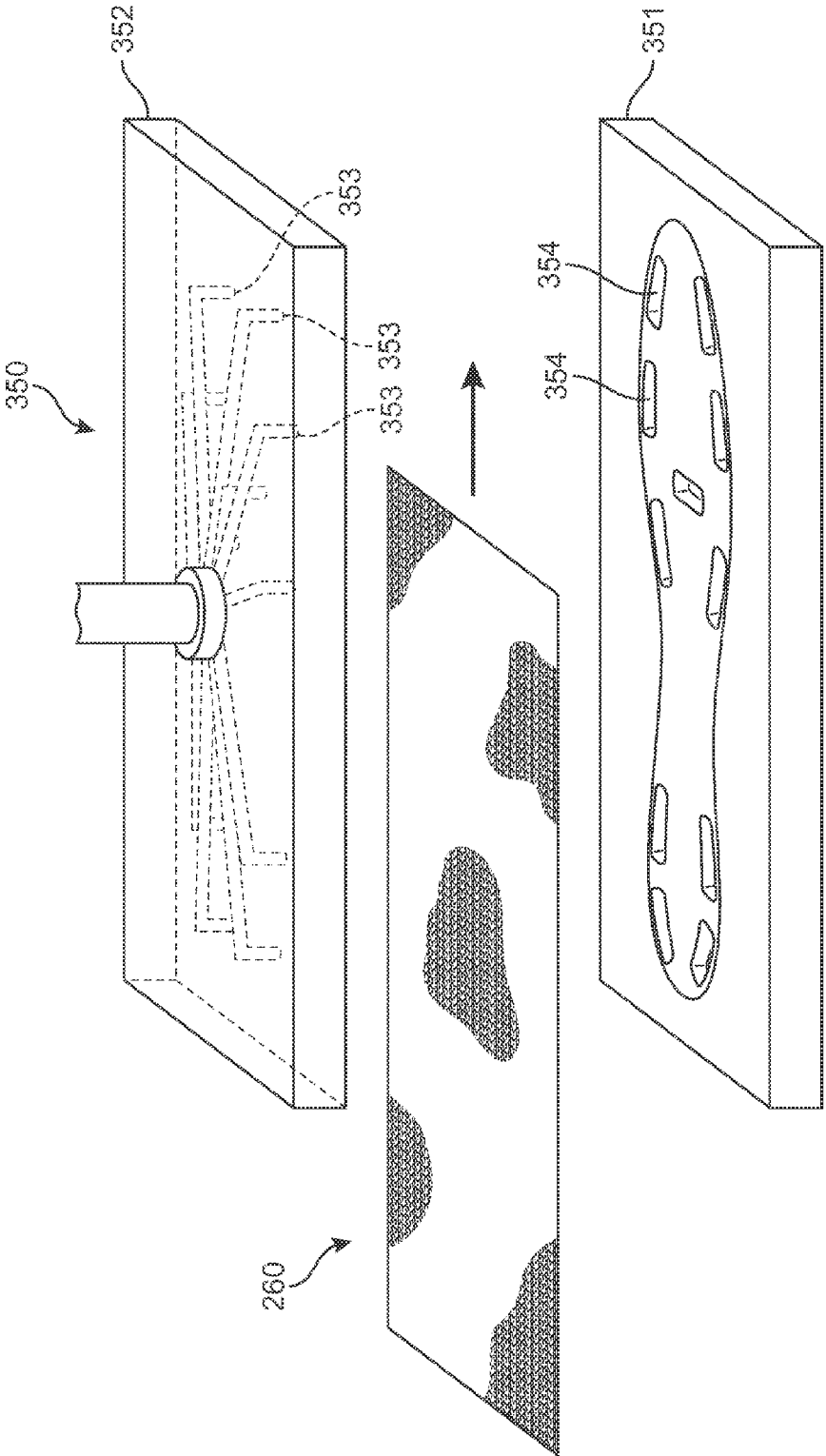

FIG. 14

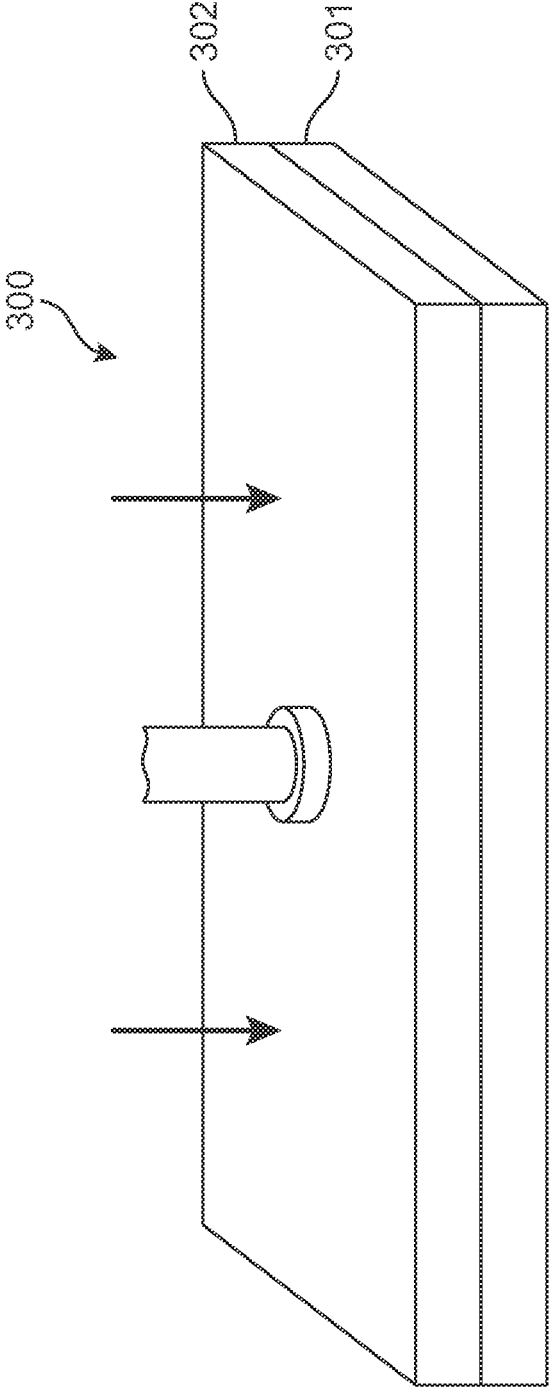

FIG. 15

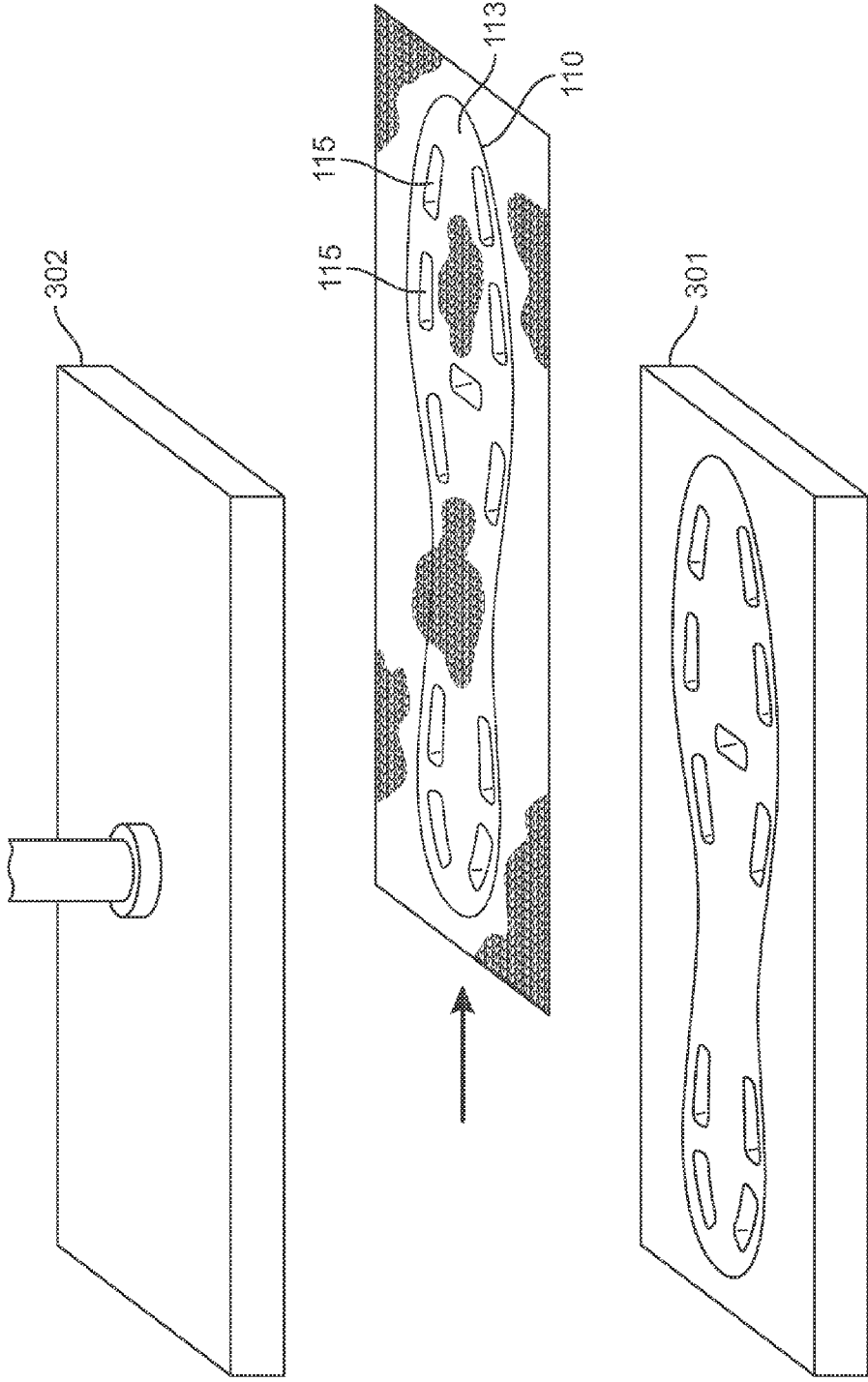

FIG. 16

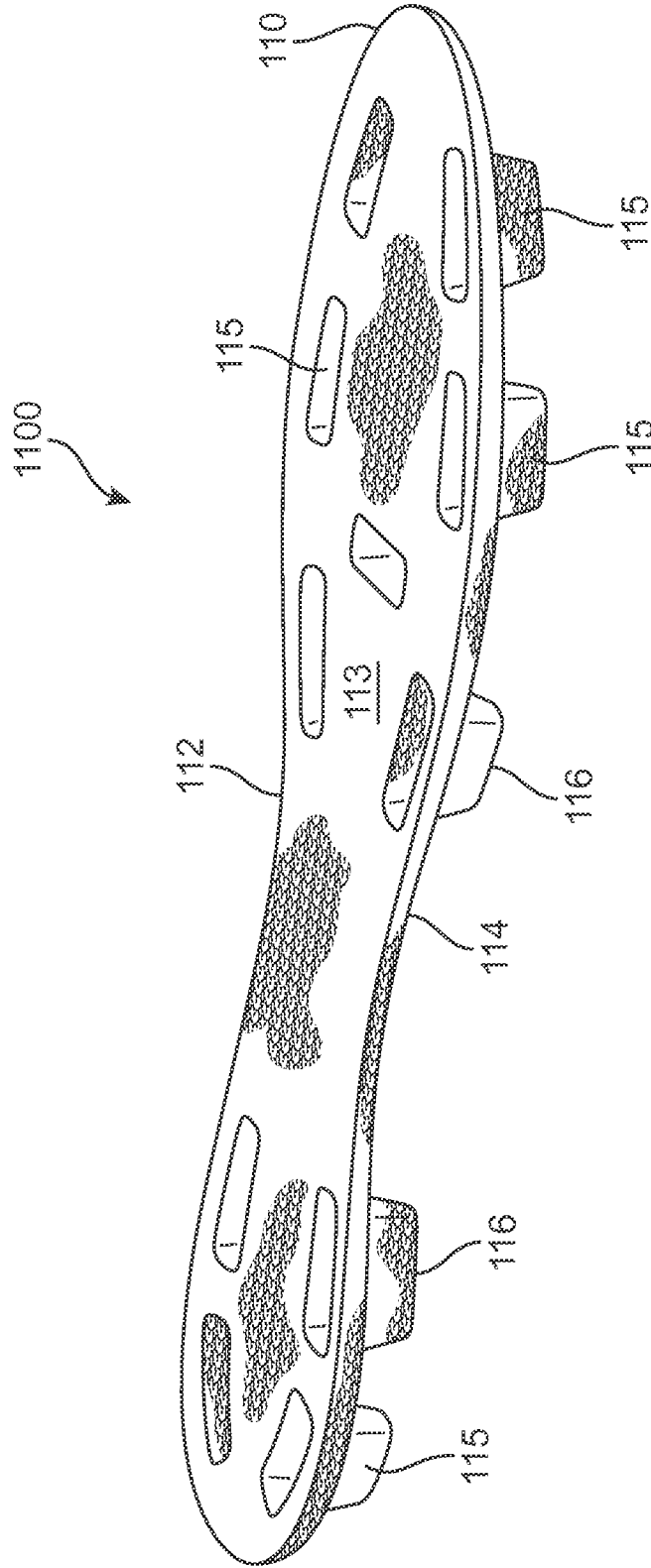

FIG. 17

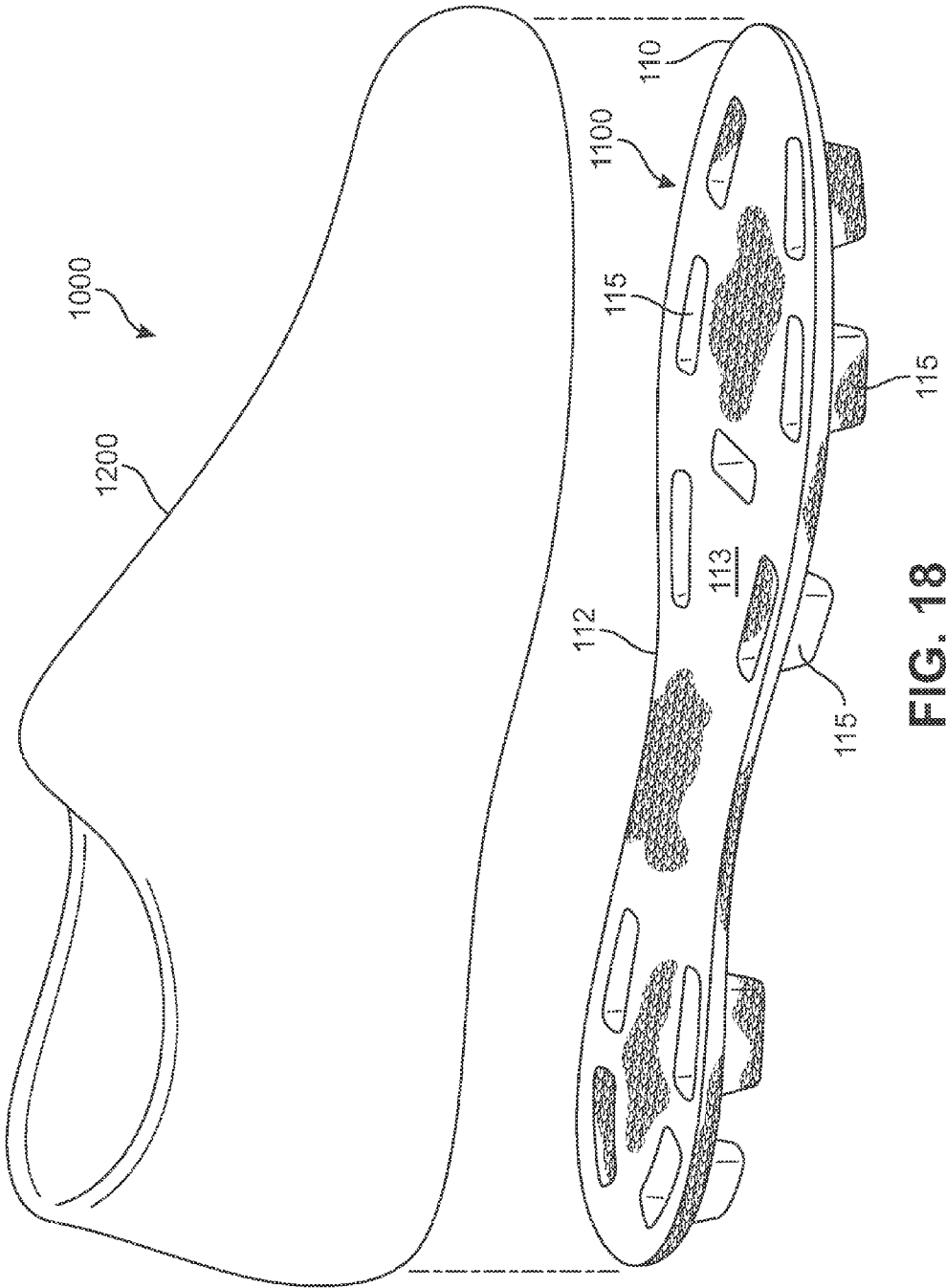

FIG. 18

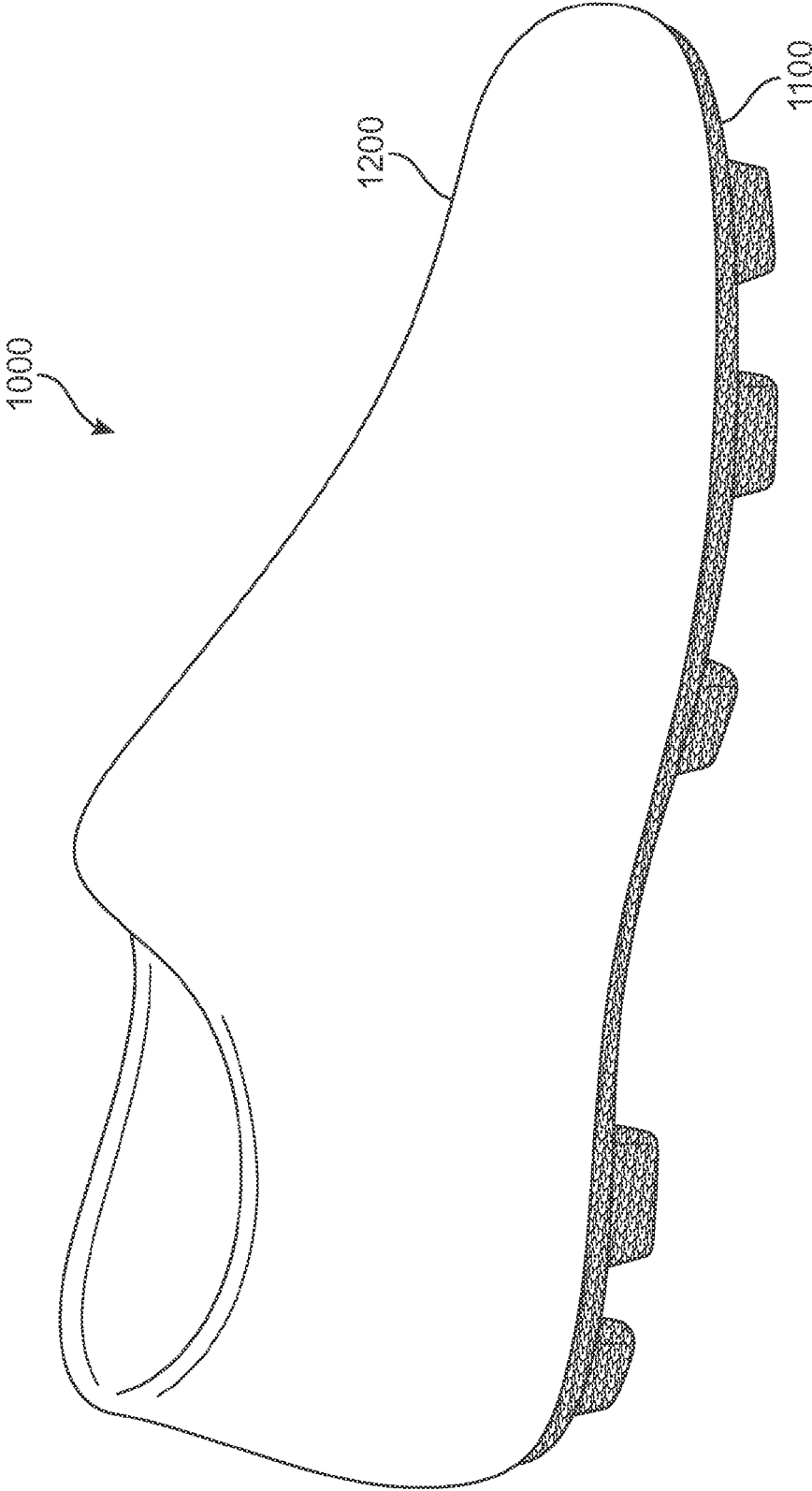

FIG. 19

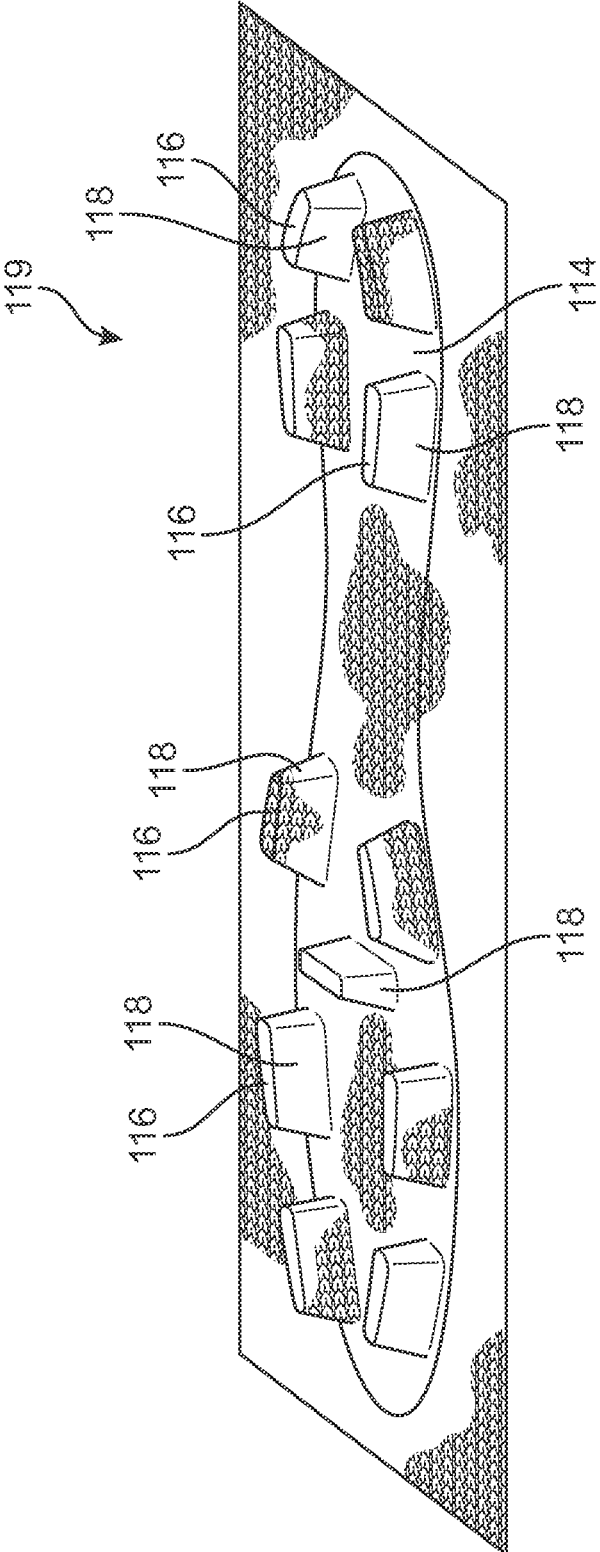

FIG. 20

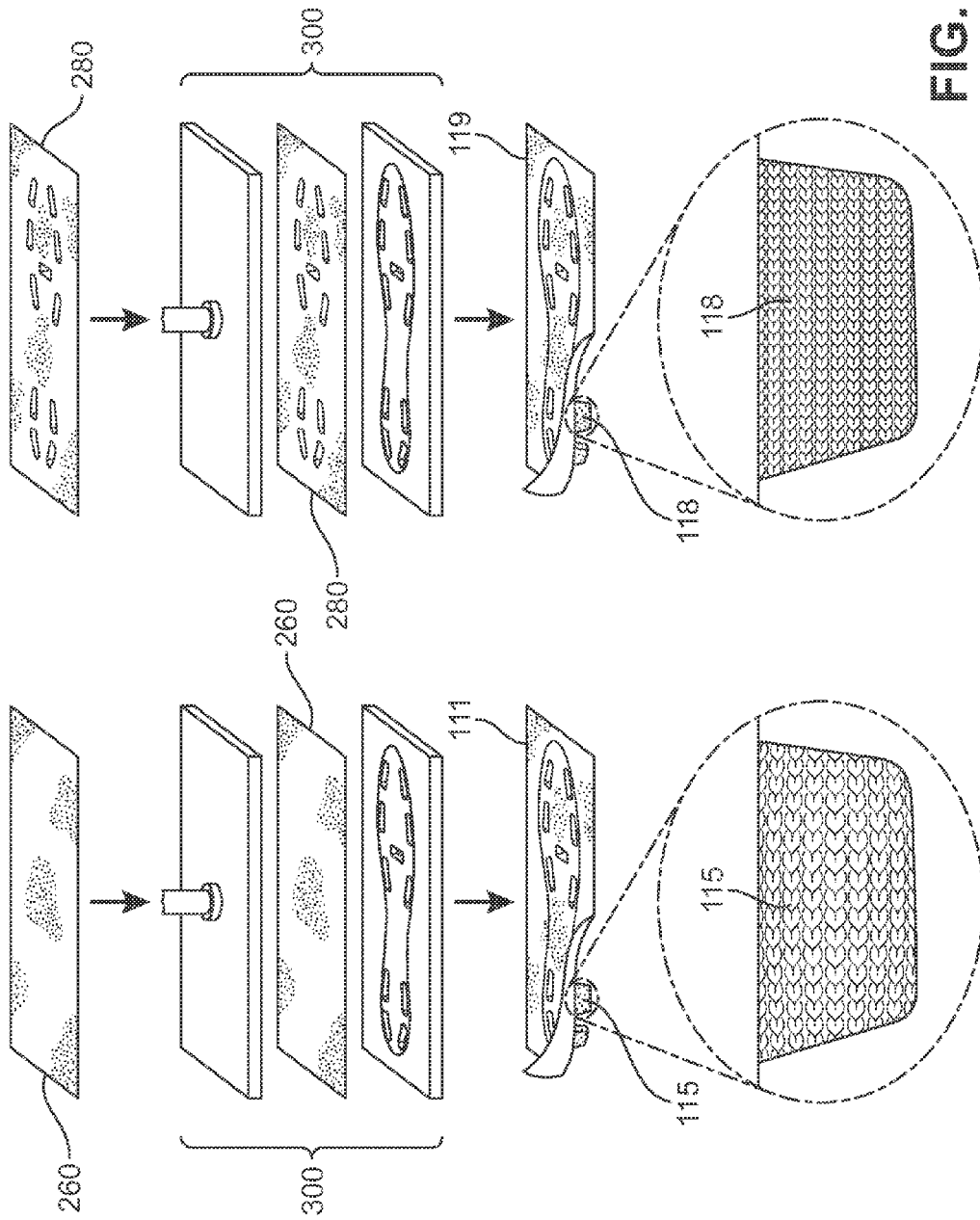

FIG. 21

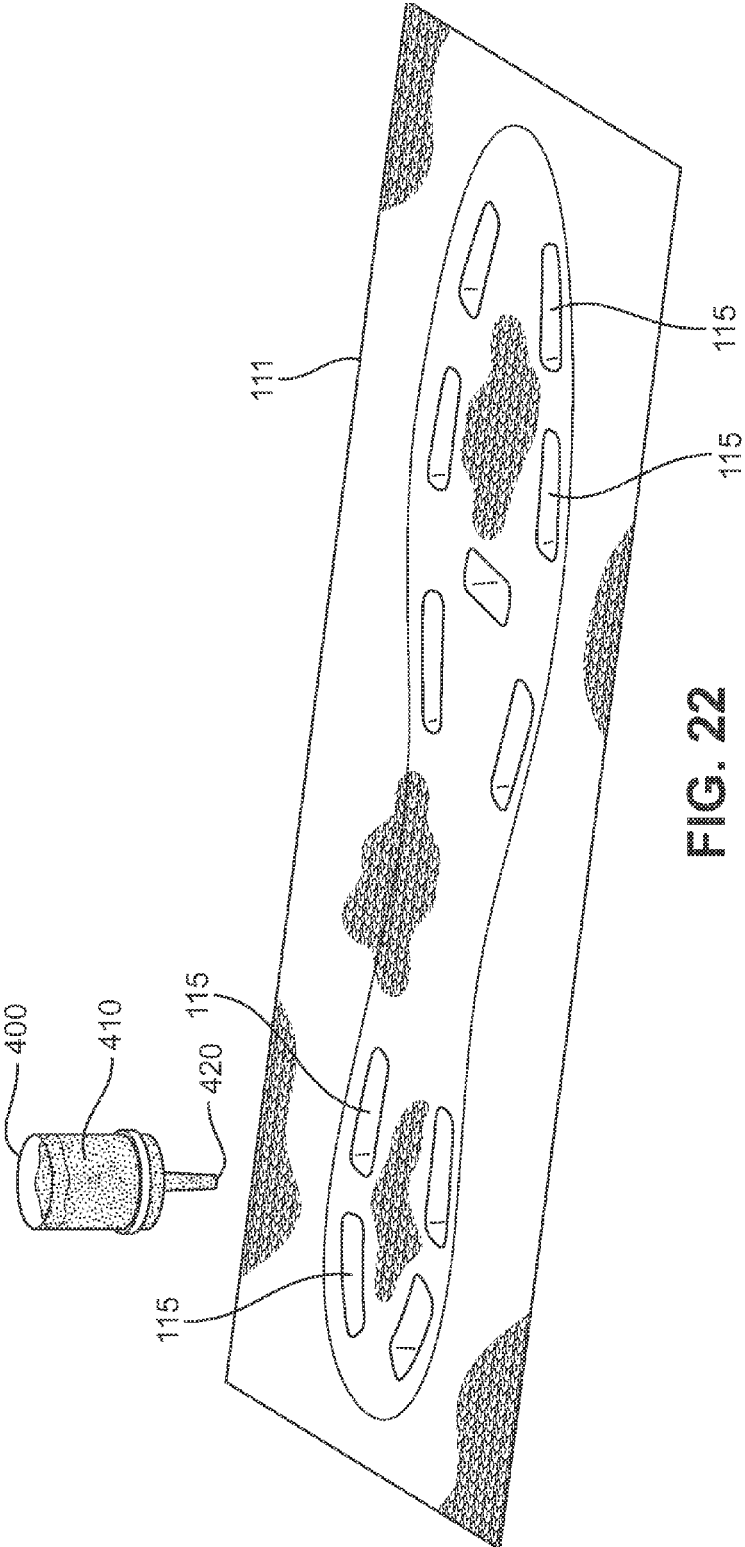

FIG. 22

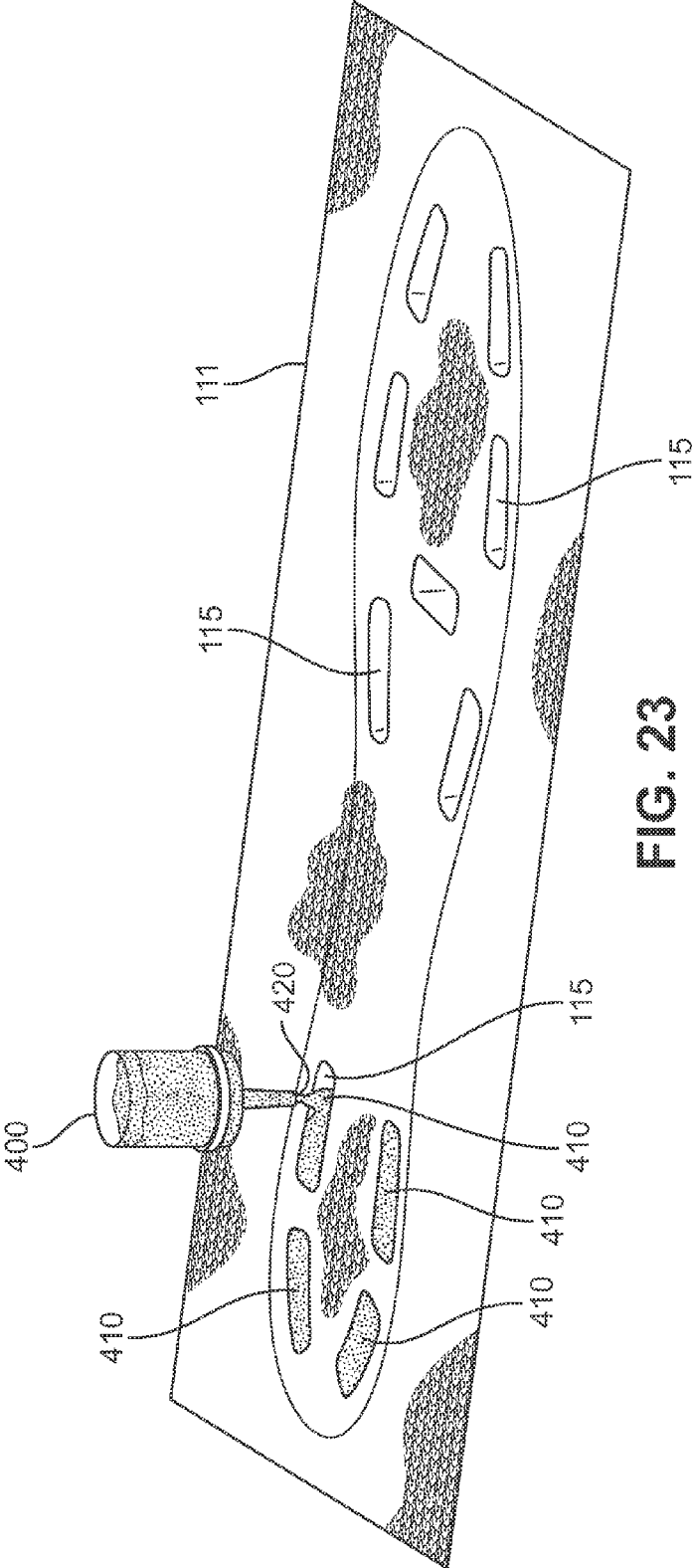

FIG. 23

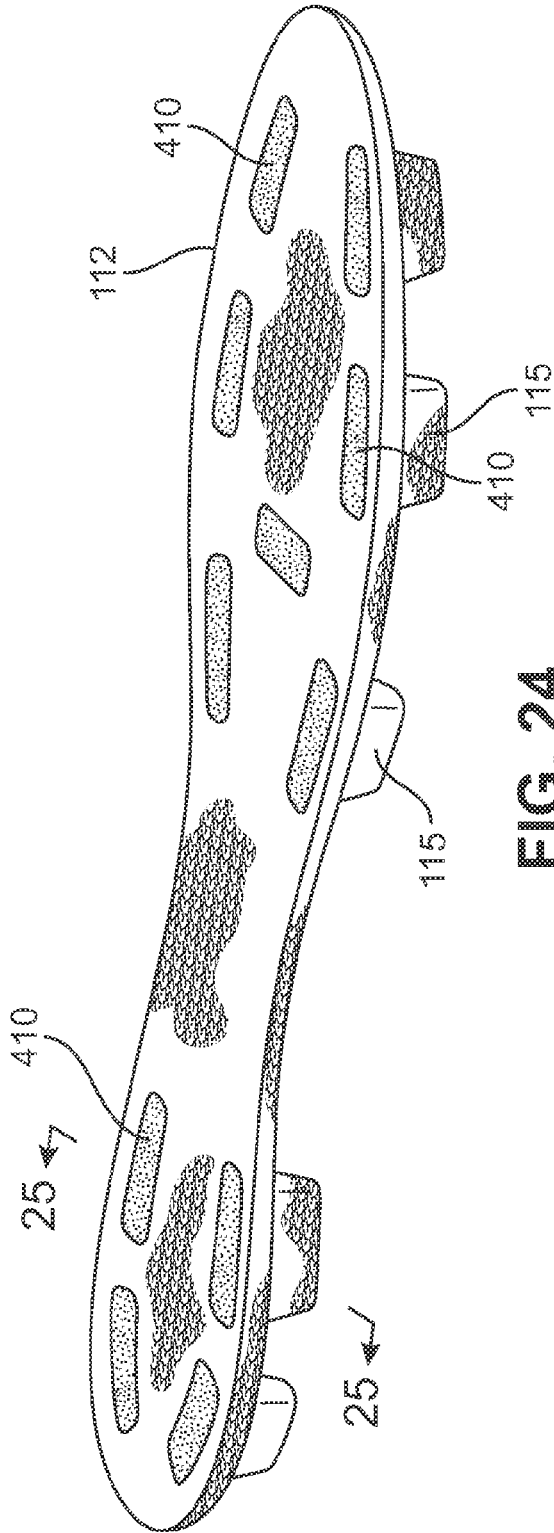

FIG. 24

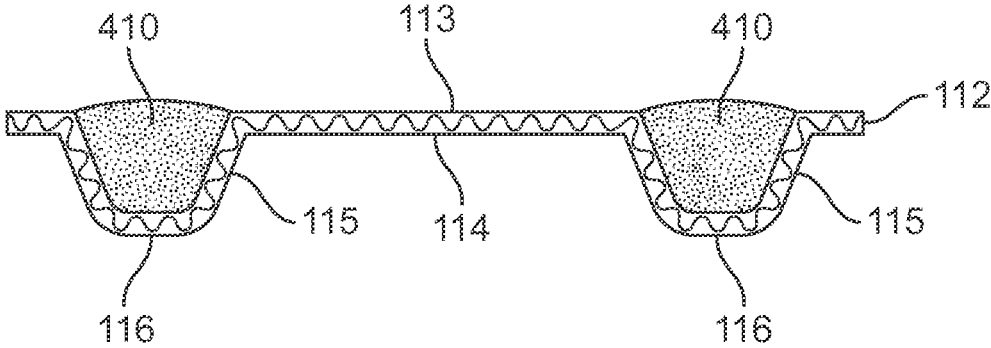

FIG. 25

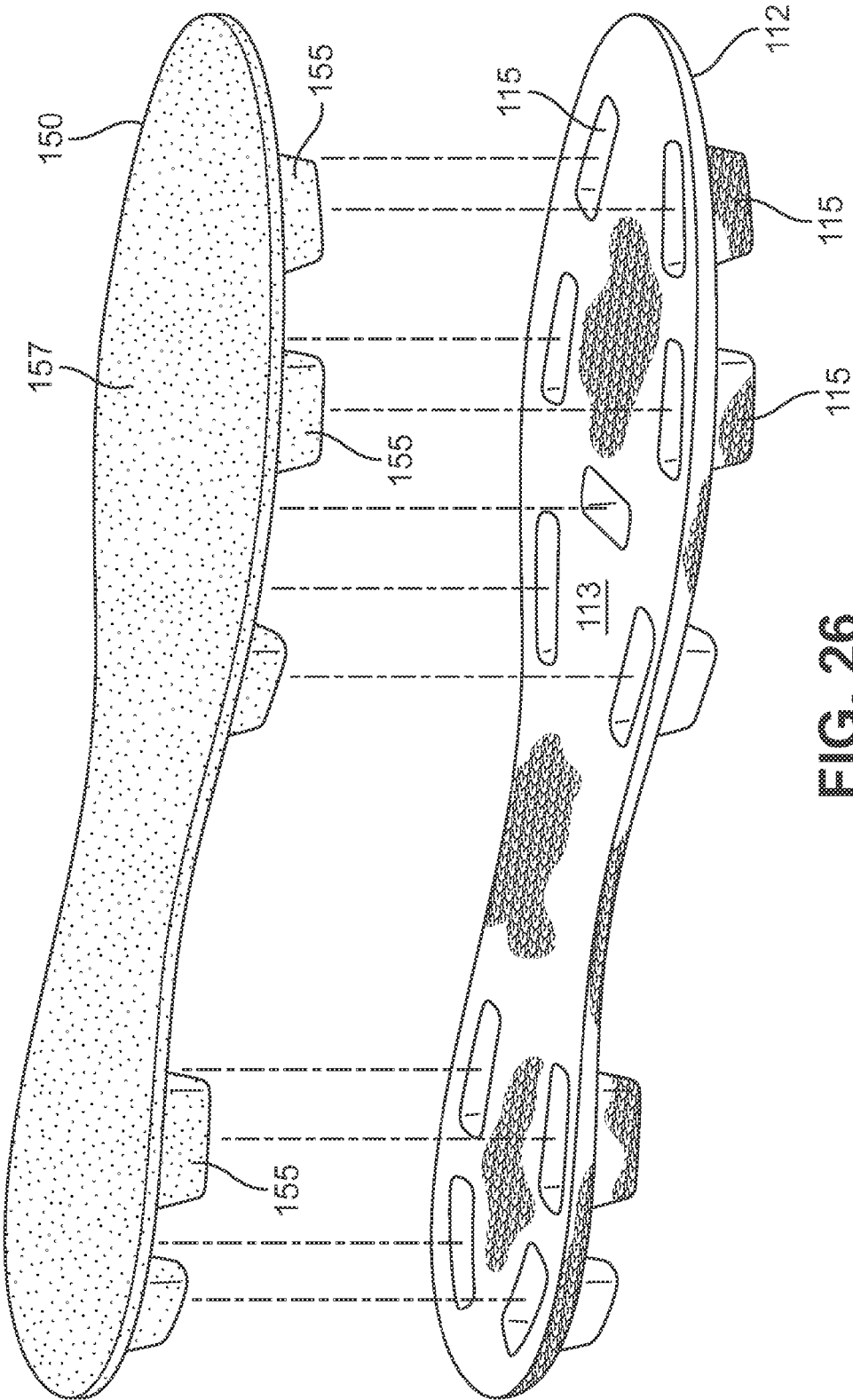

FIG. 26

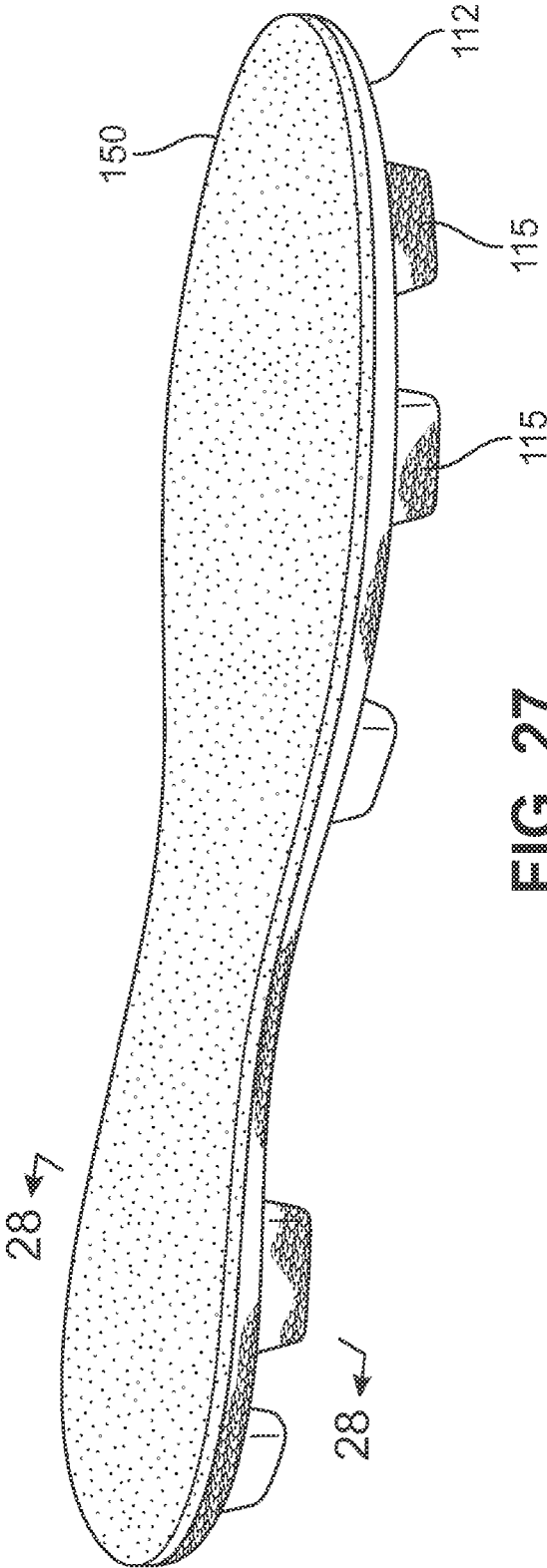

FIG. 27

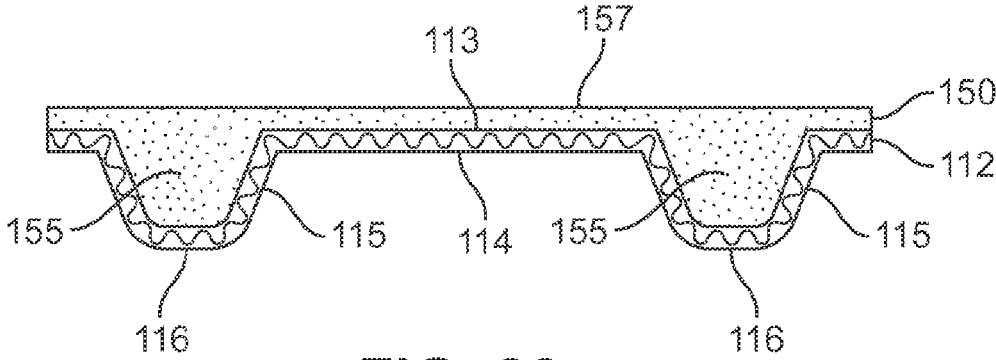

FIG. 28

**SOLE SYSTEM FOR AN ARTICLE OF
FOOTWEAR INCORPORATING A KNITTED
COMPONENT WITH A ONE-PIECE KNIT
OUTSOLE**

BACKGROUND

[0001] The present disclosure relates generally to a sole system for an article of footwear incorporating a knitted component with a one-piece knit outsole. The present disclosure also relates to an article of footwear comprising the knitted component. The present disclosure further is related generally to a method of knitting the knitted component, and to a method of making an article of footwear comprising the knitted component.

[0002] Conventional articles of footwear generally include two primary elements, an upper and a sole structure. The upper is secured to the sole structure and forms a void on the interior of the footwear for comfortably and securely receiving a foot. The sole structure is secured to a lower area of the upper, thereby being positioned between the upper and the ground. In athletic footwear, for example, the sole structure may include a midsole and an outsole. The midsole often includes a polymer foam material that attenuates ground reaction forces to lessen stresses upon the foot and leg during walking, running, and other ambulatory activities. Additionally, the midsole may include fluid-filled chambers, plates, moderators, or other elements that further attenuate forces, enhance stability, or influence the motions of the foot. The outsole is secured to a lower surface of the midsole and provides a ground-engaging portion of the sole structure formed from a durable and wear-resistant material, such as rubber. The sole structure may also include a sockliner positioned within the void and proximal a lower surface of the foot to enhance footwear comfort.

[0003] The upper generally extends over the instep and toe areas of the foot, along the medial and lateral sides of the foot, under the foot, and around the heel area of the foot. In some articles of footwear, such as basketball footwear and boots, the upper may extend upward and around the ankle to provide support or protection for the ankle. Access to the void on the interior of the upper is generally provided by an ankle opening in a heel region of the footwear. A lacing system is often incorporated into the upper to adjust the fit of the upper, thereby permitting entry and removal of the foot from the void within the upper. The lacing system also permits the wearer to modify certain dimensions of the upper, particularly girth, to accommodate feet with varying dimensions. In addition, the upper may include a tongue that extends under the lacing system to enhance adjustability of the footwear, and the upper may incorporate a heel counter to limit movement of the heel.

[0004] Articles of footwear often are constructed of many components. For example, an article of footwear may include many components, such as an upper, a sockliner, a strobrel, a midsole, and an outsole. An outsole may have spikes, cleats, or other protrusions to provide additional traction under selected circumstances. Each of these components is attached to at least one, typically two, and maybe three or more of the other components. Some components thus are stitched to, adhered to, or otherwise attached to other components.

[0005] Construction of an article of footwear comprising many components may require that components having significantly different properties and characteristics must be attached to each other. For example, an upper may be formed from cloth, a midsole from soft foam, and an outsole from

wear-resistant rubber. These components often can be adhered with adhesives. Adhesive may fail, causing delamination of the components. Further, wear may occur at joints between harder and softer materials, or between dissimilar materials. Therefore, such joints may cause premature failure of the article of footwear. Such joints also may provide uncomfortable sudden transitions between areas of softer or more compliant materials and areas of harder or more rigid materials.

[0006] Further, assembly of multiple components may be time-consuming and may lead to errors. For example, components from one style of an article of footwear may incorrectly be used on a different style of footwear. The number of potential errors and premature failures may be significant.

[0007] A variety of material elements (e.g., textiles, polymer foam, polymer sheets, leather, synthetic leather) are conventionally utilized in manufacturing an article of footwear. In athletic footwear, for example, the upper may have multiple layers that each include a variety of joined material elements. As examples, the material elements may be selected to impart stretch-resistance, wear-resistance, flexibility, air-permeability, compressibility, comfort, and moisture-wicking to different areas of the upper. Similarly, the sole structure may utilize a number of components to provide selected properties and characteristics. To impart the different properties to different areas of the article of footwear, material elements are often cut to desired shapes and then joined together, usually with stitching or adhesive bonding. Moreover, the material elements often are joined in a layered configuration to impart multiple properties to the same areas. As the number and type of material elements incorporated into the article of footwear increases, the time and expense associated with transporting, stocking, cutting, and joining the material elements also may increase. Waste material from cutting and stitching processes also accumulates to a greater degree as the number and type of material elements incorporated into the article of footwear increases. Moreover, articles of footwear with a greater number of material elements may be more difficult to recycle than articles of footwear formed from fewer types and numbers of material elements. By decreasing the number of material elements utilized in the article of footwear, therefore, waste may be decreased while increasing the manufacturing efficiency and recyclability of the upper.

[0008] Reducing the number of material elements may require that one material element provide multiple and additional properties and characteristics sought by users. Thus, there exists a need in the art for articles of footwear comprising a minimum number of material elements while providing a number of properties and characteristics sought by users.

SUMMARY

[0009] Various configurations of an article of footwear may have an upper and a sole system associated with the upper. Both the upper and the sole system may incorporate a knitted component.

[0010] In one aspect, the disclosure provides a sole system for an article of footwear. The sole system includes a knitted component incorporating a one-piece knit outsole. The knit outsole has a ground-facing side and a top side. A protruding ground-engaging cleat member is formed on the ground-facing side of the knit outsole.

[0011] In another aspect, the disclosure provides an article of footwear including the sole system. The article of footwear

includes an upper and the sole system connected thereto. The upper may be one-piece or may have a strobel sock or other closure at the bottom of the upper. The top side of the outsole and the bottom of the upper are affixed.

[0012] The disclosure also provides an aspect including a method of making a sole system for an article of footwear. In accordance with the method, a ground-engaging member is formed in a one-piece knit outsole having a ground-facing side and a top side. A protruding ground-engaging cleat member is formed by molding the knitted component.

[0013] In another aspect, the disclosure provides a method of making a sole system for an article of footwear. In accordance with the method, a one-piece knitted component is knitted to include a knit outsole. A ground-engaging cleat member is formed in the ground-facing side of the knit outsole by knitting.

[0014] In still another aspect, the disclosure provides a foot-enclosing sole system for an article of footwear. The sole system includes a one-piece foot-enclosing knit portion that encloses the foot and includes a knit outsole. The knit outsole has a ground-facing side and a top side. A ground-engaging cleat member protrudes from the ground-facing side of the outsole.

[0015] Other systems, methods, features, and advantages of the invention will be, or will become, apparent to one of ordinary skill in the art upon examination of the following figures and detailed description. It is intended that all such additional systems, methods, features and advantages be included within this description and this summary, be within the scope of the invention, and be protected by the following claims.

BRIEF DESCRIPTION OF THE DRAWINGS

[0016] The invention can be better understood with reference to the following drawings and description. The components in the figures are not necessarily to scale, emphasis instead being placed upon illustrating the principles of the invention. Moreover, in the figures, like reference numerals designate corresponding parts throughout the different views.

[0017] FIG. 1 is a perspective view of an exemplary embodiment of an article of footwear;

[0018] FIG. 2 is a lateral side elevational view of the exemplary embodiment of an article of footwear;

[0019] FIG. 3 is a medial side elevational view of the exemplary embodiment of an article of footwear;

[0020] FIG. 4 is a bottom view of an exemplary embodiment of an article of footwear;

[0021] FIG. 5 is a bottom view of an exemplary embodiment of an article of footwear before a foot-enclosing portion is formed;

[0022] FIG. 6 is a perspective view of the bottom of an exemplary embodiment of the article of footwear of FIG. 5 as the foot-enclosing portion is formed;

[0023] FIG. 7 is a perspective view of an exemplary embodiment of the completed article of footwear of FIG. 5 and FIG. 6;

[0024] FIG. 8 is an exploded view of an exemplary embodiment of an article of footwear in use;

[0025] FIG. 9 is a schematic diagram of an exemplary embodiment of a method of making an article of footwear;

[0026] FIG. 10 is a perspective view of a knitting process using conventional feeders;

[0027] FIG. 11 is a perspective view of a knitting process using conventional feeders;

[0028] FIG. 12 is a perspective view of an exemplary embodiment of a knitted component;

[0029] FIG. 13 is a view of a mold and a knitted component to be molded to form cleat members;

[0030] FIG. 14 is a view of a mold and a knitted component to be molded by injecting material to form cleat members;

[0031] FIG. 15 is a view of a mold closed on a knitted component to form cleat members;

[0032] FIG. 16 is a perspective view of a molded knitted component removed from the mold;

[0033] FIG. 17 is a perspective view of an outsole having molded cleat members;

[0034] FIG. 18 illustrates a relationship between the outsole of FIG. 17 and an upper;

[0035] FIG. 19 illustrates an assembled article of footwear, with the upper attached to the outsole;

[0036] FIG. 20 is a perspective view of the bottom of a knitted component of FIG. 17;

[0037] FIG. 21 is a comparison of cleat members that are stamped or stretched into a knitted component and cleat members that are knitted, including a close up of resultant knit pattern on the cleat members;

[0038] FIG. 22 is a perspective view of a preparation for reinforcing cleat members;

[0039] FIG. 23 is a perspective view of a method for reinforcing cleat members;

[0040] FIG. 24 is a perspective view of a knit outsole with reinforced cleat members;

[0041] FIG. 25 is cross-sectional view of the reinforced cleats at line 25-25 of FIG. 24;

[0042] FIG. 26 is a perspective view of a midsole with protrusions to register with ground-engaging cleat members of a knit outsole;

[0043] FIG. 27 is a perspective view of a knit outsole with a midsole;

[0044] FIG. 28 is cross-sectional view of the filled cleats at line 28-28 of FIG. 26.

DETAILED DESCRIPTION

[0045] An article of footwear **100** is depicted in FIGS. 1-4 as including a sole system **110** and an upper **120**. Although footwear **100** is illustrated as having a general configuration suitable for enhanced traction, concepts associated with footwear **100** may also be applied to a variety of other enhanced traction-type athletic footwear types, including baseball shoes, cycling shoes, football shoes, soccer shoes, and hiking boots, for example. The concepts may also be applied to footwear types that are generally considered to be non-athletic, including work boots. Accordingly, the concepts disclosed with respect to footwear **100** apply to a wide variety of footwear types.

[0046] The following discussion and accompanying Figures disclose a variety of concepts relating to knitted components and the manufacture of knitted components. Although the knitted components may be utilized in a variety of products, an article of footwear that incorporates one of the knitted components is disclosed below as an example. The description will be directed in detail to an article of footwear. However, in addition to footwear, the knitted components may be utilized in other types of apparel (e.g., gloves or mittens) where the ability to securely grip an object may be enhanced by protuberances. Accordingly, the knitted components and other concepts disclosed herein may be incorporated into a variety of products for both personal and industrial purposes.

[0047] For reference purposes, footwear 100 may be divided into three general regions: a forefoot region 101, a midfoot region 102, and a heel region 103. Forefoot region 101 generally includes portions of footwear 100 corresponding with the toes and the joints connecting the metatarsals with the phalanges. Midfoot region 102 generally includes portions of footwear 100 corresponding with an arch area of the foot. Heel region 103 generally corresponds with rear portions of the foot, including the calcaneus bone. Footwear 100 also includes a lateral side 104 and a medial side 105, which extend through each of forefoot region 101, midfoot region 102, and heel region 103 and correspond with opposite sides of footwear 100. More particularly, lateral side 104 corresponds with an outside area of the foot (i.e., the surface that faces away from the other foot), and medial side 105 corresponds with an inside area of the foot (i.e., the surface that faces toward the other foot). Forefoot region 101, midfoot region 102, heel region 103, lateral side 104, and medial side 105 are not intended to demarcate precise areas of footwear 100. Rather, forefoot region 101, midfoot region 102, heel region 103, lateral side 104, and medial side 105 are intended to represent general areas of footwear 100 to aid in the following discussion. In addition to footwear 100, forefoot region 101, midfoot region 102, heel region 103, lateral side 104, and medial side 105 may also be applied to sole system 110, upper 120, and individual elements thereof.

[0048] Embodiments of the disclosure provide a sole system for an article of footwear. The sole system includes a knitted component incorporating a one-piece knit outsole. The knit outsole has a ground-facing side and a top side. A protruding ground-engaging cleat member is formed on the ground-facing side of the knit outsole. The ground-engaging cleat member has a surface comprising a knitted textile that engages the ground.

[0049] Sole system 110 is secured to upper 120 and extends between the foot and the ground when footwear 100 is worn. The primary elements of sole system 110 are a knitted component 111, a one-piece knit outsole 112, an outsole top surface or side 113 (see FIG. 16), an outsole bottom surface or side 114, and a ground-engaging cleat member 115. Knitted component 111 forming one-piece knit outsole 112 is secured to a lower surface of upper 120 and may be formed from a one-piece knitted component. One-piece knit outsole 112 is secured to upper 120 and may be formed from knitted component 111. Outsole top surface or side 113 is located on the top surface of one-piece knit outsole 112, and is positioned to extend under a lower surface of the foot. Outsole bottom surface or side 114 comprises the outer bottom ground-facing surface of sole system 110 and the bottom surface of article of footwear 100. This side of the sole faces away from the foot, and may be ground-engaging if, for example, ground-engaging cleat member 115 becomes embedded in the ground. Ground-engaging cleat members 115 protrude from outsole bottom surface 114. Bottom 116 of ground-engaging cleat member 115 engages the ground first. Although this configuration for sole system 110 provides an example of a sole system that may be used in connection with upper 120, a variety of other conventional or nonconventional configurations for sole system 110 may also be utilized. Accordingly, the features of sole system 110 or any sole system utilized with upper 120 may vary considerably.

[0050] Additional embodiments provide a foot-enclosing sole system for an article of footwear. The sole system includes a one-piece foot-enclosing knit portion that encloses

the foot and includes a knit outsole. The sole system thus includes both an outsole and an upper. The outsole and the upper may be knit together as a one piece element. The knit outsole has a ground-facing side and a top side. A ground-engaging cleat member protrudes from the ground-facing side of the outsole. The ground-engaging cleat member may include a knit surface that contacts the ground.

[0051] Upper 120 defines a void within footwear 100 for receiving and securing a foot relative to sole system 110. The void is shaped to accommodate the foot and extends along a lateral side of the foot, along a medial side of the foot, over the foot, around the heel, and under the foot. Access to the void is provided by an ankle opening 121 located in at least heel region 103. In further configurations, upper 120 may include additional elements, such as (a) a heel counter in heel region 103 that enhances stability, (b) a toe guard in forefoot region 101 that is formed of a wear-resistant material, (c) a collar extending around ankle opening 121, and (d) logos, trademarks, and placards with care instructions and material information.

[0052] Many conventional footwear uppers are formed from multiple material elements (e.g., textiles, polymer foam, polymer sheets, leather, and synthetic leather) that are joined through stitching or bonding, for example. In contrast, in embodiments of the disclosure, a majority of upper 120 may be formed from a knitted component 130, which extends through each of forefoot region 101, midfoot region 102, and heel region 103 along both lateral side 104 and medial side 105, over forefoot region 101, and around heel region 103. In addition, knitted component 130 forms portions of both an exterior surface and an opposite interior surface of upper 120. As such, knitted component 130 defines at least a portion of the void within upper 120. In some configurations, knitted component 130 may also extend under the foot.

[0053] Thus, in one aspect, the disclosure provides a method of making a sole system for an article of footwear. In accordance with the method, a one-piece knitted component is knitted to include a knit outsole. A ground-engaging cleat member is formed in the ground-facing side of the knit outsole by knitting. A protruding ground-engaging cleat member may be formed by molding the knitted component. The cleat member may have a ground-engaging surface comprising a knitted surface that engages the ground and may provide traction.

[0054] Embodiments including a foot-enclosing sole system provide an article of footwear that may be formed from a one-piece knitted component. Thus, the upper and the outsole may comprise a knitted textile formed together as a one-piece element. Forming an article of footwear as a one piece textile element through knitting provides significant advantages over typical articles of footwear. For example, there is no need to attach an outsole to an upper, thus significantly reducing the number of steps required for assembly and, therefore, the possibility of assembly errors. Also, there are no joints at which disparate properties and characteristics of the joined materials may cause excessive wear and premature failure.

[0055] In some embodiments, knitted component 130 and sole system 110 comprise a single knitted component. FIG. 1 through FIG. 4 illustrate such an embodiment, wherein knitted component 130 and sole system 110 comprise a single knitted component. In these embodiments, knitted component 130 and knitted component 111 of sole system 110 are formed of unitary knit construction so as to be a one-piece element. Joint 117 depicts a joint between upper 120 and sole

system 110. However, for embodiments including sole system 110 having a one-piece foot-enclosing knit portion that encloses the foot and includes a knit outsole, joint 117 is not present. Rather, joint 117 is illustrated as a line of demarcation between sole system 110 and upper 120. No indicia corresponding to joint 117 may actually be physically present or visible on article 100.

[0056] In various embodiments, knitted component 130 may incorporate various types of yarn that impart different properties to separate areas of upper 120. For example, one area or portion of knitted component 130 may be formed from a first type of yarn that imparts a first set of properties, and another area or portion of first knitted component 130 may be formed from a second type of yarn that imparts a second set of properties. In this configuration, properties may vary throughout upper 120 by selecting specific yarns for different areas of knitted component 130. Similarly, knitted component 111 of sole system 110 may be knitted from various yarns, including any of the yarns used to form knitted component 130.

[0057] Yarns used in embodiments of the disclosure may be selected from monofilament yarns and multifilament yarns formed from natural or synthetic materials. Multifilament yarns may be twisted or untwisted. In some embodiments, yarn may be elastic or essentially inelastic. In some embodiments, yarn may be textured or have a natural finish. Natural materials may be selected from staple materials, such as silk, cotton, and wool. Synthetic materials may be selected from polymers that can be formed into filaments. Synthetic materials include but are not limited to polyesters; polyamides, such as any of the various types of homopolymeric and copolymeric nylon; aramides, such as Kevlar® and Nomex®; and urethanes, such as thermoplastic polyurethane. Fusible yarns also may be suitable for embodiments.

[0058] In embodiments of the disclosure, the yarn used to form the article of footwear may incorporate yarns with different deniers, materials (e.g., cotton, elastane, polyester, rayon, wool, and nylon), and degrees of twist, for example. The different types of yarns may affect the physical properties of a knitted component, including aesthetics, stretch, thickness, air permeability, and abrasion-resistance. In some configurations, multiple yarns with different colors may be utilized to form the knitted component. When yarns with different colors are twisted together and then knitted, the knitted component may have a heathered appearance with multiple colors randomly distributed throughout.

[0059] Other embodiments provide an article of footwear including the sole system. The article of footwear includes an upper and the sole system connected thereto. The upper may be one-piece or may have a strobel sock or other closure at the bottom of the upper. The top side of the outsole and the bottom of the upper are affixed. The surface of the ground-engaging cleat member on the sole system comprises a knitted textile, and the textile engages the ground.

[0060] In some embodiments, sole system 110 and knitted component 130 may be formed of unitary knit construction such that they may be knitted as a one-piece element to form a foot-enclosing knit portion 140. FIG. 5 illustrates such an embodiment. FIG. 5 illustrates an essentially planar or flat foot-enclosing knit portion 140 comprising sole system 110 and knitted component 130. Knitted component 130 is illustrated in two elements on opposite sides of sole system 110. Sole system 110 includes knitted component 111 forming one-piece knit outsole 112 having bottom surface 114, and

ground-engaging cleat member 115 having bottom 116. Line of demarcation 117 is illustrated for purposes of reference.

[0061] FIG. 5, FIG. 6, and FIG. 7 illustrate an exemplary process of forming article of footwear 100 from foot-enclosing knit portion 140, which is flat or planar in FIG. 5, and is configured into a completed article of footwear 100 in FIG. 7. FIG. 6 illustrates an intermediate stage, wherein foot-enclosing knit portion 140 has been folded or bent upward from about line of demarcation 117, clearly distinguishing sole system 110 from knitted component 130. Knitted component 111, one-piece knit outsole 112 having bottom surface 114, and ground-engaging cleat member 115 having bottom 116 are clearly visible as part of sole system 110. In FIG. 6, the forefoot area is completely formed, but the heel edges of knitted component 130 have not been brought together.

[0062] FIG. 7 illustrates a complete article of footwear 100 from foot-enclosing knit portion 140. Article of footwear 100 comprises knitted component 130 and sole system 110. Upper 120 is formed by stitching or otherwise attaching the ends of knitted component 130 at seam 127 in the forefoot region and the midfoot region and at seam 129 in the heel region to form a void for a wearer's foot.

[0063] In some embodiments, seam 127 and seam 129 resulting from the stitching or joining together of the sides of knitted component 130 may be located essentially on the longitudinal midline of article of footwear 100 if the size of knitted component 130 is essentially the same on each side of article of footwear 100, as illustrated in the drawing Figures herein. In other embodiments of the disclosure, the seam may be located anywhere on the surface of upper 120. Such an adjustment can be made by making one side of knitted component 130 wider than the other.

[0064] Line of demarcation 117 illustrates a dividing line between sole system 110 and other components of the article of footwear 100. Ground-engaging cleat member 115 protrudes away from the bottom side or surface 114 of one-piece knit outsole 112.

[0065] FIG. 8 illustrates an article of footwear in use by player P, with an exploded view of article of footwear 100 in contact with ground G. In this exploded view, upper 120 and ground-engaging cleat member 115 protruding from the bottom surface 114 of one-piece knit outsole 112 are clearly seen. Ground-engaging cleat member 115 makes contact with ground G at bottom surface 116 of ground-engaging cleat member 115. In this embodiment, bottom surface 116 of ground-engaging cleat member 115 is a knit surface directly in contact with the ground. Portions of bottom surface 114 of one-piece knit outsole 112 also may contact the ground directly, such as on uneven ground surfaces or when ground-engaging cleat member 115 is embedded in the ground.

[0066] FIG. 9 is a block schematic diagram of a method 500 for manufacturing an article of footwear in accord with the disclosure. In accordance with the method, a textile element (such as knitted component 111 and/or knitted component 130) is knit in step 520. Ground-engaging cleat members are formed in step 540. The textile may be steamed to set the yarn, in accordance with known processes. Then, areas of the textile element may be stiffened at method step 560. Typically, such stiffening would be useful in areas of the textile element subject to heavy abrasion. Fusible yarn may be used in this area, for example, on portions of knitted components corresponding to protuberances forming ground-engaging cleat members. Fusible yarn may be heated at step 563 to soften the outer surfaces of the yarn. Alternatively, a stiffening resin or

plastic may be applied and activated and cured or heated at step 566. Then, the final folding, matching, sticking and adhering to form the article of footwear is carried out as step 590 to form an article of footwear.

[0067] In one aspect, the disclosure provides a sole system for an article of footwear. The sole system includes a knitted component incorporating a one-piece knit outsole. The knit outsole has a ground-facing side and a top side. A protruding ground-engaging cleat member is formed on the ground-facing side of the knit outsole.

[0068] In another aspect, the disclosure provides an article of footwear including the sole system. The article of footwear includes an upper and the sole system connected thereto. The upper may be one-piece or may have a strobel sock or other closure at the bottom of the upper. The top side of the outsole and the bottom of the upper are affixed.

[0069] The disclosure also provides an aspect including a method of making a sole system for an article of footwear. In accordance with the method, a ground-engaging member is formed in a one-piece knit outsole having a ground-facing side and a top side. A protruding ground-engaging cleat member is formed by molding the knitted component.

[0070] Knitted component 111, knitted component 130, and foot-enclosing knit portion 140 can be formed of unitary knit construction. As used herein, the term “unitary knit construction” means that the respective component is formed as a one-piece element through a knitting process. That is, the knitting process substantially forms the various features and structures of unitary knit construction without the need for significant additional manufacturing steps or processes. A unitary knit construction may be used to form a knitted component having structures or elements that include one or more courses of yarn or other knit material that are joined such that the structures or elements include at least one course in common (i.e., sharing a common yarn) and/or include courses that are substantially continuous between each of the structures or elements. With this arrangement, a one-piece element of unitary knit construction is provided. Examples of various configurations of knitted components and methods for forming knitted components with unitary knit construction are disclosed in U.S. Pat. No. 6,931,762 to Dua; U.S. Pat. No. 7,347,011 to Dua, et al.; U.S. Patent Application Publication 2008/0110048 to Dua, et al.; U.S. Patent Application Publication 2010/0154256 to Dua; and U.S. Patent Application Publication 2012/0233882 to Huffa, et al.; each of which is incorporated herein by reference in its entirety. Knitted component 111, knitted component 130, and foot-enclosing knit portion 140 remain formed of unitary knit construction when other elements, such as logos, trademarks, placards with care instructions or other information, such as material information and size, tensile or structural elements, are added following the knitting procedure.

[0071] In still another aspect, the disclosure provides a foot-enclosing sole system for an article of footwear. The sole system includes a one-piece foot-enclosing knit portion that encloses the foot and includes a knit outsole. The knit outsole has a ground-facing side and a top side. A ground-engaging cleat member protrudes from the ground-facing side of the outsole.

[0072] Various methods, machines, and tools can be used for forming, treating, and otherwise adjusting knitted component 111 and for forming article of footwear 100 incorporating one-piece knit outsole 112. It will be appreciated that the order of steps within the method may vary from the order

described herein. Certain steps or aspects of some steps may be skipped or eliminated as well. Moreover, two or more steps within the method may be carried out sequentially or simultaneously. Furthermore, the steps within the method may be carried out manually or automatically, using any suitable tool, machine, or implement.

[0073] FIG. 10 and FIG. 11 illustrate an exemplary process of knitting a knitted component, including a knitted component substantially similar to knitted component 111, knitted component 130, and foot-enclosing knit portion 140 described above. Although knitting may be performed by hand, the commercial manufacture of knitted components is generally performed by knitting machines. An example of a knitting machine 200 that is suitable for producing any of the knitted components described herein is depicted in FIG. 10. Knitting machine 200 has a configuration of a V-bed flat knitting machine for purposes of example, but any of the knitted components described herein may be produced on other knitting machines.

[0074] Knitting machine 200 includes first needle bed 232 and second needle bed 234 having needles 202 that are angled with respect to each other, thereby forming a V-bed. That is, needles 202 from first needle bed 232 lay on a first plane, and needles 202 from the second needle bed 234 lay on a second plane. The first plane and the second plane are angled relative to each other and meet to form an intersection that extends along a majority of a width of knitting machine 200. As described in greater detail below, needles 202 each have a first position where they are retracted and a second position where they are extended. In the first position, needles 202 are spaced from the intersection where the first plane and the second plane meet. In the second position, however, needles 202 pass through the intersection where the first plane and the second plane meet.

[0075] Rail 203 and rail 205 extend above and parallel to the intersection of needles 202 and provide attachment points for standard feeder 204. Rail 203 and rail 205 each have two sides, each of which may accommodate one standard feeder. Therefore, knitting machine 200 may include a total of four feeders. Three such feeders are illustrated in FIG. 10. Standard feeder 204 is on the front of rail 203, feeder 214 is on the front of rail 205, and feeder 224 is on the back of rail 205. Although two rails are depicted, additional rails could be present. Such additional rails would accommodate additional feeders. Such feeders may be useful to manufacture embodiments including two or more types of yarn. These additional feeders are supplied with yarn and are operated in the same way as the feeders described in detail.

[0076] Feeder 204 moves along rail 203 and needle beds 232 and 234, thereby supplying yarn to needles 202. Yarn 206 is provided to feeder 204 by a spool 207. More particularly, yarn 206 extends from spool 207 to various yarn guides 208, yarn take-back spring 209, and yarn tensioner 210 before entering feeder 204. Although not depicted, additional spools 207 may be utilized to provide yarns to other feeders.

[0077] Standard feeders are conventionally utilized for a V-bed flat knitting machine 200. Each feeder has the ability to supply yarn that needles 202 manipulate to knit, tuck, and float. In some embodiments, only one feeder may be needed. In other embodiments, such as when the ground-engaging cleat members are knitted into the one-piece outsole, more than one feeder may be utilized. For such embodiments, a knitting machine 200 in FIG. 10 may include first standard feeder 204, second standard feeder 214, and third standard

feeder 224 that are substantially similar to each other. First standard feeder 204 may be secured to a front side of rail 203, second standard feeder 214 may be secured to a front side of rail 205, and third standard feeder 224 may be secured to a rear side of rail 205. In other embodiments of the disclosure, additional feeders may be used and may be located on the front or rear side of rail 203.

[0078] In this embodiment, first yarn 206 from spool 207 passes through first standard feeder 204 and an end of yarn 206 extends outwardly from first dispensing tip 213 at the end of first feeder arm 212. Although yarn 206 is depicted, any other strand (e.g., a filament, thread, rope, webbing, cable, chain, or yarn) may pass through first standard feeder 204. A second yarn (not shown) similarly passes through second standard feeder 214 and extends outwardly from second dispensing tip 233 on second feeder arm 215. A third yarn (not shown) may pass in a similar manner through third standard feeder 224 to third dispensing tip 233 on third feeder arm 227.

[0079] Needles 202 are manipulated to form loops 206, with a plurality of loops forming knitted component 260. The knitting process discussed herein relates to the formation of a knitted component 260, which may be any knitted component, including knitted components that are similar to knitted component 111, knitted component 130, and foot-enclosing knit portion 140. For purposes of the discussion, only a relatively small section of knitted component 260 is shown in the Figures in order to permit the knit structure to be illustrated. Moreover, the scale or proportions of the various elements of knitting machine 200 and knitted component 260 may be enhanced to better illustrate the knitting process.

[0080] First standard feeder 204 includes first feeder arm 212 with first dispensing tip 213. First feeder arm 212 is angled to position first dispensing tip 213 in a location that is (a) centered between needles 202 and (b) above an intersection of needle beds 201. Note that needles 202 lay on different planes, which planes are angled relative to each other. That is, needles 202 lay on the different planes of first needle bed 232 and second needle bed 234. Needles 202 each have a first position in which needles 202 are retracted, and a second position, in which needles 202 are extended. In the first position, needles 202 are spaced from the intersection where the planes upon which needle beds 201 meet. In the second position, however, needles 202 are extended and pass through the intersection where the planes upon which needle beds 201 meet. That is, needles 202 cross each other when extended to the second position. It should be noted that first dispensing tip 213, second dispensing tip 223, and third dispensing tip 233, are located above the intersection of the planes. In this position, first dispensing tip 213, second dispensing tip 223, and third dispensing tip 233 supply yarn to needles 202 for purposes of knitting, tucking, and floating.

[0081] Referring again to FIG. 11, first standard feeder 204 moves along rail 203 and a new course is formed in knitted component 260 from yarn 206. More particularly, needles 202 pull sections of yarn 206 through the loops of the prior course, thereby forming the new course. Accordingly, courses may be added to knitted component 260 by moving standard feeder 204 along needles 202, thereby permitting needles 202 to manipulate yarn 206 and form additional loops from yarn 206.

[0082] The processes and methods for knitting a knitted component described and illustrated herein are exemplary and are not meant to be exhaustive. Therefore, it should be understood that additional knitted components including the

features of the embodiments described herein, as well as similar knitted components including the features of the embodiments described herein, as well as similar knitted components not explicitly described herein, may be made using one or more knitting processes substantially similar to the knitting method for knitted components described herein or in the documents incorporated by reference.

[0083] Knitted components described herein can be formed from at least one yarn that is manipulated (e.g., with a knitting machine) to form a plurality of intermeshed loops that define a knitted component having a variety of courses and wales. Thus, adjacent areas of a knitted component can share at least one common course or at least one common wale. That is, knitted components can have the structure of a knitted textile. It will be appreciated that the knitted components can be formed via weft knitting operations, including flat knitting operations and circular knitting operations, warp knitting operations, or other suitable methods.

[0084] The knitted components may incorporate various types and combinations of stitches and yarns. With regard to stitches, the yarn forming the knitted components may have one type of stitch in one area of a knitted component and another type of stitch in another area of the knitted component. Depending upon the types and combinations of stitches utilized, areas of knitted components may have a plain knit structure, a mesh knit structure, or a rib knit structure, for example. The different types of stitches may affect the physical properties of a knitted component, including aesthetics, stretch, thickness, air permeability, and abrasion-resistance. That is, the different types of stitches may impart different properties to different areas of the knitted component. With regard to yarns, the knitted component may have one type of yarn in one area of a knitted component 130 and another yarn in a different area of the knitted component.

[0085] Although embodiments of the disclosure have been described in detail as providing an upper comprising a single layer, the disclosure also contemplates uppers having plural layers. The plural layers may be fused, double-knit, or otherwise associated with each other.

[0086] FIG. 12 illustrates a portion of a knitted component 260, which may represent any of knitted component 111, knitted component 130, or foot-enclosing knit portion 140. In particular, the portion is that portion in which ground-engaging cleat member 115 will be formed, so it includes portions that will become one-piece knit outsole 112, and ground-engaging cleat member 115.

[0087] Although the disclosure is described in detail as it relates to a knitted component for a sole system for an article of footwear, the principles described herein may be applied to any textile element to provide a knit surface on a protruding portion of an object to engage another object. For example, the principles may be applied to studs that protrude from the front or back of a glove or mitten to provide a secure grip on an object grasped with the glove or mitten. In such a case, the knitted component on the surface of the protruding object would not be ground-engaging, but rather would be object-engaging.

[0088] The disclosure also is described in detail as it relates to knitted textiles formed by weft knitting, but textiles formed by any suitable knitting process, including but not limited to: weft knitting processes, for example, flat knitting operations or circular knitting operations; warp knitting process; or any other knitting process suitable for providing a knitted textile, may be used.

[0089] A ground-engaging member may be formed on the knitted component in the sole system. The ground-engaging member protrudes from the ground-facing surface of the outsole. At least the bottom surface of the ground-engaging member engages the ground, and the sides of the ground-engaging member also may engage the ground.

[0090] In some embodiments, a ground-engaging member may be formed by stretching the knitted component in the area of the outsole where the ground-engaging member is to be located to form a protuberance. Typically, protuberances are found in the forefoot and in the heel, although protuberances may be placed anywhere on the outsole surface. If plural ground-engaging members are to be formed, they may be formed by stretching the knitted component individually, essentially simultaneously, in groups, or simultaneously to form the protuberances.

[0091] In some embodiments, a mold may be formed by any suitable method. The mold may have a single protuberance, or may have a protuberance for each ground-engaging member to be formed by the stretching operation. In other embodiments, two molds may be necessary. One mold may be used to form protuberances extending from the forefoot area, and the second mold may be used to form protuberances extending from the heel area.

[0092] In some embodiments, all protuberances are formed essentially simultaneously. A mold may have a male part and a mated female part into which the male part is pressed. The knitted component is placed in an open mold, typically on the female part of the open mold. The knitted component is located so that the portion of the knitted component that forms the bottom of the sole is appropriately registered with the portions of the female mold that form the protuberances. The mold ensures that the knitted component is retained at the edges so that the protuberances are formed by stretching, rather than by forcing extra textile into the cavity and wrinkling the remainder of the knitted component. Then, the male part of the mold is pressed into the knitted component and into the female part of the mold to form the protuberances in the sole. The mold parts then are separated, and the knitted component with protuberances is advanced for further processing.

[0093] FIG. 13 through FIG. 16 illustrate the method steps by which ground-engaging cleat members may be formed. Mold 300 is open, and knitted component 260 is placed between mold male part 302 and mold female part 301, as shown by the direction of the arrow. The mold is closed and the mold secures the edges of knitted component 260 to ensure that knitted component 260 is stretched to form ground-engaging cleat members 115 when the mold is closed.

[0094] FIG. 15 illustrates that male mold part 302 and female mold part 301 are moved together to press knitted component 260 therebetween. FIG. 16 illustrates that the mold parts have been separated, and one-piece outsole 112 has formed. In particular, the top surface of the outsole 113 and ground-engaging cleat member 115 are visible as the knitted textile is removed in the direction of the arrow from the separated mold.

[0095] In other embodiments, all protuberances may be formed essentially simultaneously by injection molding. Injection molding uses a fluid under pressure to form protuberances in a surface, here the knitted component. Injection molding may be used to inject materials such as elastomers and thermoplastic and thermosetting polymers. The knitted component is held in place and the knitted component is stretched to form the protuberances. Typically, thermoplastic

polymers are used because such materials are well-suited for injection molding. Thermoset materials may react too quickly or not quickly enough while being injected. Further, thermoplastic polymers may be re-used and recycled, thus making such material an environmentally sensitive choice.

[0096] A knitted component is correctly oriented on the female mold part. Then, the mold is closed. The other part of the mold contains runners and other tubes for delivering the injected material through nozzles to the mold cavity. Heated material is forced into the mold cavity to stretch the knitted component and form the protuberances. The material cools and hardens to the configuration of the protuberances. The molds then are separated and the molded knitted component is removed.

[0097] In some embodiments, the injected material may remain in the protuberances to provide rigidity. In some such embodiments, an additional feature such as a shank may be formed between the forefoot portion and the heel portion. The shank may provide additional rigidity to the outsole and thus to an article of footwear made with the sole system. In other embodiments, the injected material may be removed from the protuberances. In some such embodiments, the protuberances may be filled with another rigid material, or may be filled with soft material to provide a perception of cushioning.

[0098] FIG. 14 discloses another embodiment for forming ground-engaging cleat member 115. Mold 350 includes female part 351 and injectors 352 including nozzles 353. Each nozzle 353 corresponds with a cavity 354 shaped to form a ground-engaging cleat member 115. Knitted component 260 is placed between the injection nozzles, as shown by the arrow. Then, the mold parts are brought together and a material is injected from nozzles 353 into cavities 354 to form ground-engaging cleat members 115.

[0099] The material injected may be left in a ground-engaging cleat member 115 to provide additional support. Also, the individual pieces of injected material may be connected by a sprue or another manner. A mass of injected material also may be used to form a structure that will attenuate forces from the ground-engaging cleat member 115 reinforcement into the wearer's foot. A skilled practitioner will be able, with the guidance provided herein, to select suitable materials for this purpose.

[0100] FIG. 17 through FIG. 19 illustrate assembly of an article of footwear 1000. Article of footwear 1000 comprises both an upper and a sole system in a unitary knit construction, whereas article of footwear 1000 comprises an upper separate from the sole system. FIG. 17 illustrates sole system 1100, including knitted component 111 forming a one-piece knit outsole 112 having top surface 113 and ground-engaging cleat members 115. The bottom surface or side 114 of the outsole and the ground-engaging portion 116 of selected ground-engaging cleat members 115 also are indicated.

[0101] FIG. 18 illustrates assembly of article of footwear 1000 using sole system 1100. Upper 1200 is brought into contact with sole system 1100 and affixed to the top surface 113 thereof. Upper 1200 may be made from any material, such as leather, plastic, woven materials, and the like. FIG. 19 illustrates an assembled article of footwear 1000. This article of footwear 1000 includes a one-piece knit outsole 112.

[0102] Still other embodiments provide a method of making a sole system for an article of footwear. In accordance with the method, a one-piece knitted component is knitted to include a knit outsole. A ground-engaging cleat member is formed in the ground-facing side of the knit outsole by knit-

ting. A surface of the ground-engaging cleat member may include a knitted surface that contacts the ground.

[0103] FIG. 20 illustrates knitted component 280, another embodiment of a knitted component. In this embodiment, ground-engaging cleat members 118 are knit into the one-piece knit outsole. Therefore, there is less stress in the textile in the vicinity of the ground-engaging cleat members, and in the ground-engaging cleat members. In this embodiment, ground-engaging cleat members 118 are knitted into one-piece knit outsole 112 as pockets or cavities extending from bottom surface 114 of the outsole. Each of ground-engaging cleat members 118 may be knitted from the same yarn as the remainder of the knit outsole 112; other embodiments may form pockets using a different yarn. Such embodiments may require more than one feeder on knitting machine 200.

[0104] FIG. 21 illustrates the difference in stress in the ground-engaging cleat members between stretching or molding to form ground-engaging cleat member 115 and knitting to form ground-engaging cleat member 118. Knitted component 260 and knitted component 280 are molded in molds 300 to form knitted component 111. Knitted component 260 is molded to stretch the textile of knitted component 260 to form ground-engaging cleat members 115 in knitted component 111. However, when knitted component 280 is molded to form knitted component 119, there is essentially no stretching of the knit ground-engaging cleat member 118 or of the remainder of the knit structure forming knitted component 119. The exploded views of stretched ground-engaging cleat member 115 and of unstretched ground-engaging cleat member 118 clearly illustrate this difference.

[0105] In some embodiments, the ground-engaging cleat members 115 may be reinforced from the inside. In some embodiments, a cap-type protector may be used to cover the bottom and at least a portion of the sides of the ground-engaging cleat members. In some embodiments, the ground-engaging cleat member is filled with a reinforcing material. In some embodiments, the filling may be done by using injection molding to stretch-form ground-engaging cleat members 115. In other embodiments, a midsole insert form to fill the ground-engaging cleat members is used.

[0106] FIG. 22 through FIG. 25 illustrate a method for reinforcing ground-engaging cleat members by filling them with reinforcing material. FIG. 22 illustrates knitted component 111 with stretch-formed ground-engaging cleat members 115, but knitted ground-engaging cleat members 118 also may be reinforced by filling them. Container 400 is in position to dispense filler 410 through filler nozzle 420, as illustrated in FIG. 23.

[0107] FIG. 23 further illustrates that some ground-engaging cleat members 115 have not yet been filled with reinforcing material 410. Some ground-engaging cleat members 115 may be left empty to provide a selected cushioning response. However, as illustrated in FIG. 25, each ground-engaging cleat member 115 may be filled with filler or reinforcement material 410.

[0108] FIG. 25 is a cross sectional view taken at line 25 of FIG. 24. One-piece knit outsole 112, including outsole top side 113, outsole bottom side 114, bottom surfaces 116 of ground-engaging cleat members 115, and ground-engaging cleat member 115 filled with reinforcement material 410 are illustrated in FIG. 25. As illustrated, reinforcement material 410 may extend above outsole top surface 113. The individual masses filling the ground-engaging cleat members 115 also may be connected, as described above. Bottom surface 116 of

ground-engaging cleat member 115 is a knit surface that may be directly in contact with the ground. Other surfaces of one-piece knit outsole 112, such as outsole bottom side 114, also may be in direct ground contact.

[0109] Filler material 410 may be any suitable reinforcing material. Reinforcing materials may include compositions that provide minimal support. Such compositions may be used to tune a cushioning response. More typically, however, a reinforcing material 410 may be selected for its rigidity and strength. The material may be foamed material, such as foamed plastic materials. For example, foamed thermoplastic polyurethane may be suitable. The density of foamed materials may be controlled to tune cushioning response. Higher density may give a more supportive response and better reinforcement of ground-engaging cleat members.

[0110] In some embodiments, thermoplastic material may be used because such materials may be tough and strong, and can be foamed to tune cushioning response. Thermoset materials also may be used, but may present additional complications in manufacture because the thermoset reaction should not be completed before the material is in place. Further, as set forth above, thermoplastic materials may be more easily recycled, and thus present less waste.

[0111] Reinforcing materials may be liquid or may be in powder or particulate form, particularly in a form that can be compressed into the ground-engaging cleat members to provide reinforcement. Therefore, a retaining seal may be used to retain these reinforcing materials in the ground-engaging cleat members.

[0112] In other embodiments, a properly-designed midsole insert may be used to both reinforce the ground-engaging cleat members and to provide support for the foot. Reinforcement of the ground-engaging cleat members in this way is subject to the same considerations regarding selection of reinforcing material as are set forth above, but also may be formed to provide additional comfort or support for the wearer. An additional benefit also may be obtained by designing the insert to improve the strength of the shoe by, for example, providing arch support.

[0113] Thus, in some embodiments, the midsole may be monolithic or may have zones that provide additional support or resistance to twisting, for example. Midsoles are illustrated in FIG. 26 through FIG. 28. Reinforcement zones may be more rigid than the midsole surface 157 that is in contact with the foot. Reinforcement zones may be found in the ground-engaging cleat members and in other areas of midsole 150. For example, midsole 150 may have a strengthened zone in the midfoot region for arch protection and comfort.

[0114] In some embodiments, some regions of midsole 150 may comprise foamed thermoplastic material while other regions may be formed of the same or different materials. In some embodiments, midsole 150 may comprise a zone of low-density foam, a zone of high-density foam, and a zone of unfoamed material.

[0115] Midsole 150 having reinforcing members 155 protruding from the bottom thereof is shown in relationship to one-piece knit outsole 112 in FIG. 26. Reinforcement members 155 are aligned with corresponding ground-engaging cleat members 115.

[0116] FIG. 27 illustrates midsole 150 affixed to the top surface 113 of one-piece knitted component outsole 112. A cross-sectional view at line 28, shown in FIG. 28, illustrates midsole 150 in place on the top surface 113 of one-piece knit outsole 112. Reinforcement members 155 are in place in

ground-engaging cleat members **115**. Foot-contacting surface **157** of midsole **150** is the upper surface of the assembly, and the bottom surface **116** of the ground-engaging cleat members **115** are facing downward. Bottom surface **116** of ground-engaging cleat member **115** is a knit surface that may be directly in contact with the ground. Other surfaces of one-piece knit outsole **112**, such as outsole bottom side **114**, also may be in direct ground contact.

[0117] Embodiments including a foot-enclosing sole system may comprise areas in which different yarns are used. Different types of yarns may impart different properties to different areas of the knitted component. By combining various types and combinations of stitches and yarns, each area of knitted component may have specific properties that enhance the comfort, durability, and performance of the article of footwear.

[0118] Embodiments of a sole system typically may include areas of durable yarns and fusible yarns. Durable yarns and fusible yarns typically may provide the wear resistance users likely will prefer to have in ground-engaging areas and areas of the sole system that are likely to experience greater wear. For example, the outer surface of the sole system comprises a knitted textile, but is likely to experience greater wear because the surface faces the ground and is, at least in part, adjacent ground-engaging protuberances that certainly may be ground-engaging. Further, fusible yarns may provide not only excellent wear resistance, but also support for the bottom of the foot. Strands of fusible yarn may, when heated, fuse to form an impermeable mass. Fusible yarns also may provide a highly water resistant surface that helps keep the interior of the article of footwear free of water that otherwise would enter the article of footwear from the outside.

[0119] Suitable materials also may be added anywhere on the outer surface where water resistance or another property or characteristic, such as rigidity, is sought. Such materials, typically in the form of a film, may be applied to the surface of the knitted component before the sole system is formed. Application of a film to a knitted component also may be accomplished after formation of components of the sole system.

[0120] For example, resistance of an article of footwear to incursion of water, particularly through the sole system, may be increased by affixing a thin film or water-resistant material on the outside surface of the outsole. The entirety of the outer sole surface may be covered with thin film, or only a portion or portions of the lower surface may be covered with film for wear resistance and water repellence.

[0121] Suitable thin film materials include polymers such as polyethylene and polypropylene, which may retain flexibility when bonded to the outer surface of a knitted component. Such films may suitably be used on surfaces of a knitted component that preferably retain their flexibility, such as an upper of an article of footwear. The skilled practitioner will be able to identify appropriate films.

[0122] In other embodiments, a thin film may be rigid or resistant to bending before or upon application, typically with heat and pressing. Application with heat and pressing causes the film to adhere or being adhered to the knitted component. Such rigid film may be formed of plural thin layers or one or two thicker layers. Plural materials may be stacked to form a more rigid film. A thicker, single layer also may be used.

[0123] Embodiments of a foot-enclosing sole system may include areas of softer yarns, compliant yarns, durable yarns,

and fusible yarns, for example. Softer and compliant yarns typically may be used where comfort is an important feature, with durable yarns used in areas susceptible to wear. In particular, embodiments may have fusible yarns on the outsole, the protruding ground-engaging projection, and on the ground-engaging surface. Fusible yarns may be particularly durable and may serve the same purposes ascribed to them above. Similarly, a thin film may be used to the same advantage as set forth above.

[0124] Another suitable yarn may be a core and sheath-type bi-component construction. Core and sheath construction is obtained having a sheath of material having one set of properties essentially concentric with and surrounding a core of yarn material having another set of properties and characteristics. In embodiments, the sheath material is one type of yarn having a first set of properties and characteristics. Other bi-component yarns, such as “islands in the sea” type, also may be suitable. Such yarns typically may have fusible material on the outside, just as a core and sheath fiber has fusible material as a sheath material. Still another technique may be to spray a solvent-based fusible composition onto yarn. In such embodiments, the solvent may be water, thus making the composition environmentally sensitive.

[0125] In still further embodiments, a plurality of yarns may be used to provide transition zones for areas of the knitted component. For example, whereas durable, rigid yarns may be preferred for surfaces of the knitted component that are ground-facing, such yarns may not be preferred for an upper of an article of footwear. Rather, softer, more compliant yarns may be preferred on the upper, but such yarns may wear out prematurely in areas of high abrasion or stress, such as in the area of the heel, for example. For such high abrasion areas, it may be preferable to have a durable yarn.

[0126] In some embodiments, a rigid layer may be applied to both the top side of the outsole and the ground-facing side of the outsole. Such embodiments provide a rigid outsole, yet retain the look, properties, and characteristics of a knitted textile formed from a knitted component. Further, the rigid layer of material attached to the top side of the outsole may be useful in forming a protruding ground-engaging member.

[0127] Other embodiments may include a rubberized portion on the ground-facing surface of the outsole. A rubberized portion may be formed on the surface of the outsole by painting on a rubberized material, by adhering a rubberized material to the portion of the knitted component that forms the ground-facing surface of the outsole, or in any suitable method.

[0128] In embodiments having a layer of material on the ground-facing surface of the outsole, the shape of the layer may be formed to reduce adhesion of mud and dirt to the bottom of the sole, and thus to the bottom of an article of footwear incorporating the sole system. Various geometric shapes may be formed in the covering layer, or added to the ground-facing surface of the outsole, to minimize adhesion of mud and dirt.

[0129] While various embodiments of the invention have been described, the description is intended to be exemplary rather than limiting, and it will be apparent to those of ordinary skill in the art that many more embodiments and implementations are possible that are within the scope of the embodiments. Accordingly, the embodiments are not to be restricted except in light of the attached claims and their equivalents. Also, various modifications and changes may be made within the scope of the attached claims. As used in the

claims, "any of", when identifying the previous claims, is intended to mean (i) any one claim or (ii) any combination of two or more claims identified.

- 1. A sole system for an article of footwear, the sole system including:
 - a knitted component incorporating a one-piece knit outsole;
 - wherein the knit outsole has a ground-facing side and a top side; and
 - a ground-engaging cleat member protruding from the ground-facing side of the knit outsole.
- 2. The sole system of claim 1, wherein the one-piece outsole comprises fusible yarn.
- 3. The sole system of claim 1, wherein the knitted component further comprises a first yarn and a second yarn.
- 4. The sole system of claim 1, wherein the ground-engaging cleat member is reinforced.
- 5. An article of footwear including a sole system, the article of footwear includes an upper and the sole system connected thereto;
 - the upper having a bottom;
 - the sole system including:
 - a knitted component incorporating a one-piece knit outsole,
 - wherein the knit outsole has a ground-facing side and a top side; and
 - a ground-engaging cleat member protruding from the ground-facing side of the knit outsole; and
 - the top side of the knit outsole and the bottom of the upper are affixed.
- 6. The sole system of claim 5, wherein the one-piece knit outsole comprises fusible yarn.
- 7. The sole system of claim 5, wherein the knitted component further comprises a first yarn and a second yarn.
- 8. The sole system of claim 5, wherein the ground-engaging cleat member is reinforced.
- 9. A method of making a sole system for an article of footwear, the method comprising:
 - molding a one-piece knit outsole having a ground-facing side and a top side to form a ground-engaging cleat member;

- the ground-engaging cleat member protruding from the ground-facing side of the knit outsole.
- 10. The method of claim 9, wherein the one-piece outsole comprises fusible yarn.
- 11. The method of claim 9, wherein the knitted component further comprises a first yarn and a second yarn.
- 12. The method of claim 9, wherein the ground-engaging cleat member is reinforced.
- 13. A method of making a sole system for an article of footwear, the method comprising:
 - knitting a one-piece knitted component;
 - the one-piece knitted component comprising a knit outsole;
 - the knit outsole having a top side and a ground-facing side; and
 - knitting a ground-engaging cleat member on the ground-facing side of the knit outsole.
- 14. The method of claim 13, wherein the one-piece outsole comprises fusible yarn.
- 15. The method of claim 13, wherein the knitted component further comprises a first yarn and a second yarn.
- 16. The method of claim 13, wherein the ground-engaging cleat member is reinforced.
- 17. A foot-enclosing sole system for an article of footwear, the sole system comprising:
 - a one-piece foot-enclosing knit portion that encloses the foot;
 - the one-piece foot-enclosing knit portion including a knit outsole;
 - the knit outsole having a ground-facing side and a top side; and
 - the ground-facing side of the outsole includes a protruding ground-engaging cleat member.
- 18. The sole system of claim 17, wherein the one-piece outsole comprises fusible yarn.
- 19. The sole system of claim 17, wherein the knitted component further comprises a first yarn and a second yarn.
- 20. The sole system of claim 17, wherein the ground-engaging cleat member is reinforced.

* * * * *