



(11) **EP 1 905 319 B1**

(12) **EUROPEAN PATENT SPECIFICATION**

(45) Date of publication and mention of the grant of the patent:  
**29.10.2008 Bulletin 2008/44**

(51) Int Cl.:  
**A41D 19/015 (2006.01) A63B 71/14 (2006.01)**

(21) Application number: **06020573.9**

(22) Date of filing: **29.09.2006**

(54) **Glove reinforcing element**

Handschuhverstärkungselement

Élément de renfort pour gant

(84) Designated Contracting States:  
**AT BE BG CH CY CZ DE DK EE ES FI FR GB GR HU IE IS IT LI LT LU LV MC NL PL PT RO SE SI SK TR**

(43) Date of publication of application:  
**02.04.2008 Bulletin 2008/14**

(73) Proprietor: **adidas International Marketing B.V.**  
**1062 KR Amsterdam (NL)**

(72) Inventors:  
• **Geyer, Harald**  
**91475 Lonnerstadt (DE)**  
• **Steidle, Volker, Peter**  
**90443 Nürnberg (DE)**

• **Saur, Erwin, Friedrich**  
**91126 Schwabach-Wolkersdorf (DE)**

(74) Representative: **Hess, Peter K. G.**  
**Patent- und Rechtsanwälte**  
**Bardehle . Pagenberg . Dost .**  
**Altenburg . Geissler**  
**Postfach 86 06 20**  
**81633 München (DE)**

(56) References cited:  
**WO-A-20/05065789 DE-B3-0102005 014**  
**47**  
**US-A- 5 018 221**

**EP 1 905 319 B1**

Note: Within nine months of the publication of the mention of the grant of the European patent in the European Patent Bulletin, any person may give notice to the European Patent Office of opposition to that patent, in accordance with the Implementing Regulations. Notice of opposition shall not be deemed to have been filed until the opposition fee has been paid. (Art. 99(1) European Patent Convention).

## Description

### 1. Technical field

**[0001]** The present invention relates to a glove reinforcing element, in particular for a goalkeeper glove, allowing a bending in gripping direction but avoiding a hyperextension of the fingers and/or the hand.

### 2. The prior art

**[0002]** Apart from a thermal isolation, gloves typically serve to protect the hands. Injuries are to be avoided by blocking or at least cushioning mechanical impacts onto the hand. For example, working gloves are typically made from stable and tear-resistant materials to reduce the risk of cuts to the hand.

**[0003]** A goalkeeper glove fulfills several functions. Apart from improving the grip on the inner side of the hand, it is important to protect the hand against the substantial mechanical loads when deflecting a sharply shot ball. A particular risk for a goalkeeper glove is the hyperextension of individual fingers or the thumb. When a goalkeeper tries to deflect a ball with the extended hand, there is the risk that one or two fingers of the extended hand, which barely contact the ball, are subjected to the full impact and are therefore hyperextended. Straining or even breaking a finger or the hand are the consequences. It has therefore been known for several years to provide goalkeeper gloves and gloves for sports (such as snowboard gloves), wherein the hand is subjected to particularly high loads, with active reinforcing elements. The reinforcing elements allow to bend the hand in gripping direction. However, they block a bending of the extended hand into the opposite direction, i.e. in the direction of a hyperextension. In the case of a goalkeeper glove, the extended hand and in particular individual fingers and the thumb are actively supported by the glove when deflecting a sharply shot ball.

**[0004]** To obtain the desired mechanical properties it is known from the DE 35 16 545 C2 to manufacture the backside of a glove in certain areas out of two layers. A series of compression-proof bodies are arranged on a flexible but non-yielding first layer (for example a suitable foil). A glove having such a backside can be easily bent, since the first, flexible layer does not provide any significant resistance against such a deformation. However, if the hand and the glove is extended, the compression-proof bodies of the second layer contact each other. Due to the non-yielding nature of the first layer, it is avoided that the backside of the glove can be bent in direction of hyperextension beyond the extended configuration.

**[0005]** A similar approach is known from the DE 201 13 431 U1. A glove reinforcing element is disclosed comprising a plurality of hingedly connected parts. The DE 201 13 431 U1 discloses links, each of which have a rotation pin and at the other end a corresponding bearing cavity. The links are designed such that a rotation of two

links is only possible in one direction and that the link chain blocks a movement in the opposite direction beyond the extended configuration.

**[0006]** A further design is shown in the DE 100 10 404 A1. The glove reinforcing element disclosed in this document comprises a plurality of links which are threaded onto a pulling element extending through the links. This arrangement is similar to the design of the backside of the glove according to the DE 35 16 545 C2, wherein the pulling element, for example a wire, has the function of the first, non-yielding layer.

**[0007]** However, all glove reinforcing elements known in the prior art for an active protection against hyperextension are difficult to manufacture. For example, in the designs of hingedly connected links explained above, each link must be manufactured in a first step. Subsequently, all links have to be interconnected. Since up to ten reinforcing elements are needed for a complete protection of the hands, this will lead to a significant manufacturing effort and resulting costs. As a consequence, gloves having an active protection against hyperextension can until now only be found in high-priced gloves for (semi-) professional users. In particular, it is impossible to produce gloves with a protection against hyperextension for children at costs, which would be accepted by the market, even though kids have the greatest risk of injuries.

**[0008]** A further disadvantage is the comparatively high weight of gloves having a backside as described in the DE 35 16 545 C2. The same applies to gloves having other known glove reinforcing elements. As a result, the movements of the goalkeeper become slower and he cannot quickly react to a surprise shot.

**[0009]** Furthermore, known glove reinforcing elements are typically uncomfortable and create pressure points on the backside of the finger and / or the hand, for example when a ball is deflected using the fist, so that a very high load acts locally on a reinforcing element. Glove manufacturers try to avoid this effect by providing a complex cushioning. However, such a complex cushioning further increases the price, renders the glove bulky and leads to a less direct support function of the glove reinforcing element.

**[0010]** Finally, the use of a plurality of compression-proof bodies or hinges makes it difficult to control the ball when deflecting with the fist, so that the ball is often deflected in an uncontrolled manner.

**[0011]** In a completely different technical field, i.e. the manufacture of soccer boots, it is known from the DE 27 32 463 to integrate a curved reinforcing insert into the shoe sole, which allows a bending of the shoe during rolling-off, but which stabilizes the shoe when shooting a ball.

**[0012]** DE-102005 014470 B3, discloses a glove reinforcing element according to the preamble of claim 1.

**[0013]** It is therefore the problem underlying the present invention to provide a glove reinforcing element for a protection against hyperextension which overcomes

at least some of the above mentioned disadvantages of the prior art and which can be manufactured at low costs.

### 3. Summary of the invention

**[0014]** According to one embodiment, this problem is solved by a glove reinforcing element, in particular for a goalkeeper glove, allowing a bending in gripping direction but avoiding a hyperextension of the fingers and / or the hand, comprising at least one bending area. The bending area has a curvature with a shape which allows to bend the glove reinforcing element into at least a first direction and which blocks a bending of the glove reinforcing element into at least a second direction. Furthermore, the glove reinforcing element comprises at least one blocking element arranged at the bending area.

**[0015]** The glove reinforcing element according to the invention is based on a fundamentally different mechanical principle than the reinforcing elements used in the prior art. Instead of hingedly connected links or material layers with non-yielding or compression-proof elements, the uni-directional bendability is provided by a suitable shape of the curvature of at least one bending area of the glove reinforcing element. In addition, the at least one blocking element reinforces the bending area when the bending of the glove reinforcing element is blocked.

**[0016]** In the most basic embodiment, the bending area of the glove reinforcing element according to the invention can be realized by a gutter-shaped component, since already such a shape allows to bend the glove reinforcing element into the direction of the open side of the gutter but remains rigid when bending into the opposite direction subject to a failure of the used material. A gutter-shaped curvature is only arched in one spatial direction and thus shows a curved line in a cross-section, e.g. a part of a circular arc, whereas a longitudinal section through a gutter-shaped curvature shows no curve. All further embodiments, which are described below, are therefore only optional modifications of the basic principle to provide the anisotropic bending properties of the glove reinforcing element by a suitable shape of a curvature.

**[0017]** It is apparent that the glove reinforcing element according to the invention can be significantly easier and more cost-efficiently produced than the above described constructions of the prior art. In the most simple embodiment an integral part is used which can be manufactured by injection molding a suitable plastic material. A complicated assembly of individual components is not necessary. Furthermore, the glove reinforcing element according to the invention can be easily adapted to different finger sizes, for example by using different injection molding tools.

**[0018]** In a preferred embodiment the at least one bending area of the glove reinforcing element comprises a dome-like curvature, i.e. a curvature which is curved in more than one direction. Both, a cross-section and a longitudinal section through a dome-shaped curvature lead to a curved cross-section line. In contrast to a gutter-

shaped curvature, a dome-shaped curvature allows to localize the bending at a predefined position, i.e. along a line extending essentially through the centre of the dome-shaped curvature.

5 **[0019]** In a particularly preferred embodiment, the bending area is arranged in the region of a joint of the finger and / or the wrist. Since a bent joint (wrist or finger joint) forms an upwardly curved outer surface, the glove reinforcing element can be reliably arranged so that its shape, curved in the same direction, is above the joint to be protected without requiring further measures to assure that it remains in this position. The conformation between the shape of the backside of the finger and / or the hand and the glove reinforcing element, which is preferably arranged thereon, avoids local pressure points as they occur with the canted reinforcing elements of the prior art. Preferably, the glove reinforcing element comprises a plurality of bending sections which are assigned to a plurality of finger joints.

20 **[0020]** An essentially rigid interconnection area is preferably arranged adjacent to the at least one bending area having preferably a gutter-shaped curvature and in addition preferably at least one stiffening element to avoid its deformation. In contrast to the bending area, the stiffening area remains essentially rigid in spite of its curvature, regardless in which direction the glove reinforcing element is bent. The curvature provides also here in an advantageous manner a secure arrangement of the glove reinforcing element on the backside of a finger or the hand.

30 **[0021]** The simple design of the glove reinforcing element allows a preferred manufacture as a single piece. More complex properties of the single piece component can be realized by multi-component injection molding using at least two different plastic materials. For example a plastic material of a different elasticity can be used for the bending areas than for the interconnection areas.

35 **[0022]** Reinforcing elements of the prior art are typically maintained in the correct position by permanent gluing or Velcro® connections. By contrast, it is for the glove reinforcing element of the invention preferred, if it is made from a suitable material and / or provided with a suitable coating to slide within the receptacle of a glove. As already explained above, the use of a curvature provides a high amount of conformation between the backside of the finger or the hand and the inside of the glove reinforcing element, so that it slides essentially automatically to the correct position.

40 **[0023]** The self-adjustment will be particularly effective, if the curvature of the at least one bending area and / or the at least one interconnecting area extends, as in a preferred embodiment, from the backside of a finger laterally around the finger. Furthermore, such a shape protects the finger against injuries from the side, for example caused by the hard studs on the football boot of a player. Furthermore, it is conceivable that the at least one bending area and / or the at least one interconnecting area comprises at least one cut-out. Such a cut-out fur-

ther reduces the weight of the glove reinforcing element. In addition, it allows to selectively influence the bending properties in sections of the glove reinforcing element.

**[0024]** The at least one blocking element is preferably arranged on top of the at least one bending area. Other arrangements adjacent to or below the bending area are also possible. It is further preferred that the at least one blocking element comprises at least two parts separately arranged at the at least one bending area. The two parts blockingly contact each other when the bending area blocks a bending of the glove reinforcement element during bending into the second direction. The bending presses the two parts against each other which provides a substantial, additional resistance to a hyperextension of the finger. However, bending in the opposite direction is allowed because the two parts are turned away from each other. In one embodiment, the glove reinforcing element including the at least one blocking elements is manufactured as a single piece. Alternatively, the glove reinforcing element and the at least one blocking elements can be realized by multi-component injection molding using at least two different plastic materials.

**[0025]** In a preferred embodiment, the at least one blocking element is a separate element. The at least one blocking element may be attached to the glove reinforcing element by different means such as glue, rivets, (high-frequency) welding, hook-and-loop fasteners or a clip mechanism. In a preferred embodiment, the bending area comprises at least one pin to which the blocking element is attached. If there is more than one blocking element, or if the blocking element comprises two or more separate parts, there may be more than one pin. This is particularly useful when the blocking element is made from a different material, preferably a harder material, in order to reinforce the bending area. In one embodiment, the blocking element is detachably attached to the glove reinforcing element so that the blocking element can be exchanged. This is advantageous when adjustment of the glove reinforcing element to different purposes is required, for example an adjustment to a particular load or force exerted on the glove reinforcing element.

**[0026]** Further preferred modifications of the glove reinforcing element according to the invention are defined in further dependent claims.

**[0027]** According to a further aspect, the present invention relates to a glove, in particular to a goalkeeper glove, comprising at least one glove reinforcing element in accordance with one of the above explained embodiments. Preferably, the glove has an element for the backside of the hand to which the at least one glove reinforcing element is attached, preferably in a releasable manner. The element for the backside of the hand is preferably provided as a plate protecting the backside of the hand against injuries. Such a glove protects not only against hyperextension but also against injuries as they may for example be caused by the sharp edges of studs which may contact the hands of a goalkeeper during use.

#### 4. Short description of the drawing

- [0028]** In the following detailed description a presently preferred embodiment of the invention is described with reference to the following figures:
- 5 Fig. 1: a perspective general view of a presently preferred embodiment of the glove reinforcing element;
- 10 Fig. 2a: an illustrating representation where the glove reinforcing element is arranged above the backside of the finger inside the glove (not shown);
- 15 Fig. 2b: an illustrating representation of the glove reinforcing element of Fig. 2a. in the case of a hand bent in the gripping direction;
- 20 Fig. 3: a schematic presentation of the attachment of an additional weight at one end of the embodiment of Figs. 1 and 2;
- 25 Fig. 4: a perspective presentation of a plate for the backside of the hand wherein a plurality of glove reinforcing elements of the embodiments of Figs. 1- 3 are releasably attached thereto;
- 30 Fig. 5: a side view of the plate for the backside of the hand and the attached glove reinforcing elements of Fig. 4;
- 35 Fig. 6: a perspective view of the glove reinforcing element with blocking elements according to another embodiment of the invention;
- 40 Fig. 7: a side view of the glove reinforcing element of Fig. 6;
- 45 Fig. 8: a front view of the glove reinforcing element of Fig. 6;
- 50 Fig. 9: a perspective view of the glove reinforcing element with pins and separate blocking elements according to another embodiment of the invention;
- 55 Fig. 10: a perspective view of the glove reinforcing element of Fig. 9 without blocking elements;
- Fig. 11: a perspective view of a blocking element;
- Fig. 12: a bottom view of the blocking element of Fig. 11; and
- Fig. 13: a close-up perspective view of the bending area of the glove reinforcing element of Fig. 9.

## 5. Detailed description of the preferred embodiment

**[0029]** In the following, a presently preferred embodiment of the present invention is explained with reference to a glove reinforcing element for a goalkeeper glove. However, it is to be understood that the present invention can also be used for other types of gloves, for example snowboarding or working gloves worn during activities which involve a risk of hyperextension of individual fingers, the thumb or the overall hand.

**[0030]** Fig. 1 presents a perspective view of a single glove reinforcing element 1. As can be seen, there are three, significantly upwardly curved areas 10 connected by two interconnecting areas 20. At the rear end and the front end, an end area 30 can be found.

**[0031]** As indicated by the dashed arrows in Fig. 1, the areas 10 can be elastically bent and each allow a downwardly directed bending of the glove reinforcing element 1. However, they provide a substantial resistance subject to material failure in case of bending into the opposite direction. The dotted lines in Fig. 1 indicate approximately the buckling line when bending the corresponding bending area 10. It can be seen that these lines each extend approximately through the centre of the essentially dome-like curved areas. However, the shape of the bending area 10 only roughly defines the location of the buckling line. Therefore, the position of the buckling line can within certain limits adapt to the anatomical situation of the finger arranged therebelow (cf. Fig. 2). The less dome-like the curvature of the area 10 is shaped, the greater is this adaptability. In case of an exclusively gutter-shaped curvature (not shown) the glove reinforcing element can be downwardly bent using the same force at any location of the bending area.

**[0032]** Interconnecting areas 20 are arranged between the bending areas 10. Also the interconnecting area 20 comprises a curvature. However, this curvature is preferably fully gutter-shaped and preferably adapted to the contour of the backside of a finger in sections without joints.

**[0033]** For limiting the bendability of the glove reinforcing elements to the bending area 10, the interconnecting areas 20 are each provided with ribs 21. As a result, these sections of the glove reinforcing element are essentially rigid in spite of their curvature. This property can also be achieved in a different manner, for example by manufacturing the interconnecting areas 20 from an inelastic material. As explained in detail further below, the glove reinforcing element 1 of the preferred embodiment is preferably a single piece. However, using suitable methods it can still be made from different materials. Alternatively or additionally to the interconnecting areas 20 stiffened by the ribs 21, tube-shaped interconnecting areas could be arranged (not shown), which extend over the finger like a sleeve and therefore provide a high degree of stiffness without any further measures. Another conceivable embodiment (not shown) uses only one or more reinforcing ribs 21 without a curved interconnecting surface.

**[0034]** In the presently preferred embodiment shown in Fig. 1, the interconnecting areas 20 extend laterally around the finger (not shown in Fig. 1) and protect it against injuries, for example caused by contacting the hard studs on a football boot of a soccer player or the like. In the bending areas 10 the lateral extension is slightly smaller to allow an easier bending.

**[0035]** The end areas 30 essentially correspond to the interconnecting areas 20. However, it is conceivable to provide a lower number of reinforcing ribs 21 on the end areas compared to the number of ribs on the interconnecting areas 20, e.g. one rib instead of three ribs, as shown in Fig. 1.

**[0036]** Fig. 2a shows schematically where the reinforcing element 1 shown in Fig. 1 is to be arranged inside a glove (not shown). As can be directly seen, the three bending areas 10 are arranged on top of the three joints of the finger to be protected, whereas the essentially rigid interconnecting areas 20 cover the straight finger bones extending between the joints. Fig. 2b shows the glove reinforcing element in a bent configuration. As one can see the elastic bending areas 10 are bent, whereas the substantially rigid interconnecting areas 20 are unchanged. Thus, the glove-reinforcing element also adapts itself to the bent contour of the finger. As a result, the glove reinforcing element has a shape on its inner side, which essentially corresponds to the shape of the backside of the finger so that it "latches" onto the backside of the finger and therefore automatically moves into or maintains the correct position.

**[0037]** To this end, it can be advantageous to manufacture the glove reinforcing element from a material which easily slides within certain limits inside the receptacle of the glove - typically a pocket-like cavity. This can for example be achieved by providing a coating out of a friction-reducing material, e.g. a PTFE material, such as e.g. sold by the company DuPont under the trademark Teflon® and/or by coating the receptacle inside the glove (not shown) with such a friction reducing material. Finally, the good fit of the glove reinforcing element 1 due to the sequence of dome-shaped bending areas 10 and the gutter-shaped interconnecting areas 20 leads to a significantly improved wearing comfort compared to the reinforcing elements of the prior art with their hard, typically planar shaped links which are not adapted to the positioning of the joints in the finger.

**[0038]** The two end areas 30 preferably extend slightly beyond the topmost end of the finger to be protected and its rear end, respectively. This leads to an additional protection of the finger at its front end, when a ball or the like hits the finger from the front side, since the arising load is directly taken up by the glove reinforcing element 1. At the rear end, the end area 30 has at least an extension so that a hyperextension load is securely transmitted from the glove reinforcing element 1 to the overall area of the hand.

**[0039]** Figs. 1, 2a and 2b show that also the upwardly directed upper side of the glove reinforcing element 1

has a shape which corresponds - apart from the ribs 21 - essentially to the contour of the unprotected finger. This feature facilitates to use the upper side for deflecting a ball, for example for deflecting a ball using the fist. In contrast to known reinforcing elements with a sequence of comparatively thick and hard elements having a canted shape and many edges, the glove reinforcing element of Figs. 1, 2a and 2b allows to more easily deflect the ball into a certain direction. If necessary, the stiffening ribs can be covered by a second curved surface on the outside leading to an almost complete conformation with the typical shape of the backside of a finger (not shown), which will even more improve the control over a deflected ball.

**[0040]** Fig. 3 illustrates an additional weight 40, which is arranged at the end region 30 of the glove reinforcing element 1. The additional weight 40 allows to influence the dynamic properties of the glove and thus the movements of the goalkeeper. For example an increased weight at the finger tips leads due to the arising centrifugal force automatically to a maximally extended hand configuration when the goalkeeper quickly raises his arms so that he covers the maximum area with his hands.

**[0041]** The additional weight 40 can be attached to the glove reinforcing elements in different ways, for example by clipping, screwing, lateral insertion or other releasable mounting techniques which allow to replace the additional weight against another weight of a different mass or to use the glove reinforcing element 1 without additional weight 40. In general, it is also conceivable to permanently integrate the additional weight 40 into the glove receiving element 1. Apart from the preferred arrangement at or in the end area 30, the additional weight 40 can also be arranged at any other section of the glove reinforcing element 1. In addition, it is conceivable to use different additional weights for different fingers.

**[0042]** Figs. 4 and 5 illustrate how the presently preferred embodiment of the glove reinforcing element 1 is preferably integrated into a complete protection system inside a glove (not shown). To this end, there is for each finger and, if necessary, the thumb (not shown) a glove protection element 1, which is releasably connected with a plate 50 for the backside of the hand. As already mentioned with respect to the additional weight 40, a number of known attaching methods are available for the person skilled in the art. The important aspect is that the interconnection is sufficiently stable to securely transmit the arising load on an individual glove reinforcing elements 1 into the plate 50 on the backside of the hand. In the embodiment shown in Figs. 4 and 5, the glove reinforcing elements 1 are inserted from the front into receptacles 52, which are on their top side closed by a reinforcing ridge 53 which may, if necessary, be provided with suitable latching means. The preferred contact between the rear end area 30 and the receptacle 52 includes a form fit and thereby provides the required stability.

**[0043]** The plate 50 for the backside of the hand covers preferably the overall backside of the hand and addition-

ally protects the hand, for example if a player steps with a studded shoe onto the flat hand of the goalkeeper. As can be seen in the side view of Fig. 5, the plate 50 for the backside of the hand also laterally encompasses the hand in its rear part to provide a good fit and to extend the protection also onto the side regions of the hand. Although it is not shown in Figs. 4 and 5, the plate for the backside of the hands may also comprise a bending area with a curvature in its rear part to protect the wrist in a similar manner against hyperextension, as an individual glove reinforcing element 1 of Figs. 1 - 3 protects the finger joints.

**[0044]** The glove reinforcing element of the explained embodiments is preferably manufactured as a single plastic part made by injection molding. A manufacture by extruding plastic material is also conceivable. Both methods lead to very low manufacturing costs, a low weight and allow in addition an easy adaptation to different sizes, for example for kids gloves, by using correspondingly adapted molds for injection molding. Suitable plastic materials are thermoplastic polyurethanes (TPU) or polypropylene (PP). Also the use of memory-materials is conceivable which can be brought back into the initial state by applying heat or the like, if the supporting function decreases after some time of use. However, the very cost efficient manufacture by injection molding also allows to use the discussed glove reinforcing elements as wearing parts. In this case glove reinforcing elements, which are permanently bent or no longer sufficiently stable, are simply replaced.

**[0045]** In order to provide more advanced embodiments, the preferably single piece glove reinforcing element can also be manufactured by multi-component injection molding more than one plastic material. For example a harder plastic material can be used for the interconnecting areas 20 and a particularly soft and elastic plastic material can be used for the bending areas 10 to provide a lower bending resistance, in particular for kids gloves. The multi-component injection molding may be performed simultaneously using one or more nozzles or sequentially. Alternatively, the plastic material can be injected around separately pre-manufactured components of the glove reinforcing element. For example interconnecting areas made from a sufficiently hard material (for example a metal or a composite material including carbon fiber) may be encompassed by a soft plastic material forming the bending areas 10.

**[0046]** It is also possible to modify the above explained embodiments by selectively arranging cut-outs in sections of the glove reinforcing element (not shown). The cut-outs allow to influence the bending properties. In addition, they further reduce the overall weight. The arrangement of cut-outs as well as the material selection and the exact shape of the discussed glove reinforcing element can easily be optimized using a finite-element-analysis.

**[0047]** Fig. 6 presents a perspective view of a glove reinforcing element 1 according to a further preferred em-

bodiment of the invention. As can be seen, the glove reinforcing element 1 comprises an additional blocking element 60 arranged in the bending area 10. The blocking element 60 allows bending of the glove reinforcing element 1 in a first direction (indicated by the dashed arrows in Fig. 1) and reinforces the bending area 10 when bending into a second direction (the direction opposite to the dashed arrows in Fig. 1) is blocked. As a result, the maximum load or force which can be blocked is increased.

**[0048]** Preferably, the blocking element 60 is arranged on top of the bending area 10. Alternatively, the blocking element 60 may be arranged in other suitable regions of the bending area 10. The blocking element 60 may cover a part of the bending area 10 or it may cover the whole bending area 10. Furthermore, the blocking element 60 may extend into interconnecting region 20 and may also extend from one bending area 10 to another bending area 10.

**[0049]** As can also be seen in Fig. 6, it is preferred if the blocking element 60 comprises two parts 61, 62. When the glove reinforcing element 1 is bent into the second direction, the two parts 61, 62 blockingly contact each so that a further bending is blocked. The bending presses the two parts against each other which provides a substantial, additional resistance against a hyperextension of the fingers. However, bending in the first direction is allowed because the two parts are turned away from each other.

**[0050]** In the embodiment of Fig. 6, the two parts 61 and 62 are separated by a gap 63 in the initial configuration of the glove reinforcing element 1, i.e. without bending. The size of the gap 63 may vary and become infinitely small. The two parts 61 and 62 may also be in direct contact with each other. Further, the two parts 61 and 62 may be arranged in such a way that they prebend the glove reinforcing element 1 in the first direction, i.e. the gripping direction.

**[0051]** Alternatively, the blocking element 60 may comprise more than two parts. In still another embodiment the blocking element 60 is a single piece which is adapted to allow bending of the glove reinforcing element 1 in the first direction and to block bending in the second direction.

**[0052]** As also illustrated in Fig. 6, the blocking element 60 comprises a dome-shaped curvature. In this way, the blocking element 60 is adjusted to the overall shape of glove reinforcing element 1 which reduces the risk of injuries of other players and improves the control when deflecting a ball.

**[0053]** The blocking element 60 and the glove reinforcing element 1 are preferably integrally manufactured during a single injection moulding process. Preferably, the same material is used for both elements. Alternatively, the manufacture may use co-injection of different materials with one or two moulds. In this case, the blocking element 60 is preferably made from a harder material than the glove reinforcing element 1 in order to increase the reinforcement of the bending area 10.

**[0054]** Fig. 7 is a side view of the glove reinforcing element 1 of Fig. 6. Fig. 7 clearly shows the gap 63 between the two parts 61 and 62 of the blocking element 60 in the initial configuration of the glove reinforcing element 1. As already mentioned above, the gap 63 may become infinitely small, or the two parts 61 and 61 may directly contact each other. This figure also shows the above mentioned dome-shaped curvature of the blocking element 60 which is different at its top side and its bottom side.

**[0055]** Fig. 8 is a front view of the glove reinforcing element of Fig. 6. Also from this direction, the dome-shaped curvature of the blocking element 60 can be seen.

**[0056]** A further embodiment of the invention is illustrated in Fig. 9 wherein the blocking element 60 is a separate element which is attached to the glove reinforcing element 1. The use of a separate element provides various advantages such as the use of specifically adapted materials and the possibility to exchange blocking elements, which is described in more detail below.

**[0057]** The blocking element 60 may be attached to the glove reinforcing element 1 by different means such as glue, rivets, hook-and-loop fasteners or a clip mechanism. In the embodiment illustrated in Fig. 9, the glove reinforcing element 1 comprises pins 91 on which the blocking element 60 is placed. The pins may be located in the bending area 10 or in any other area to which the blocking element 60 extends. Preferably, the pins are an integral part of the glove reinforcing element 1. Alternatively, the pins are located on the blocking element 60, and the glove reinforcing element 1 comprises corresponding holes.

**[0058]** In the preferred embodiment of Fig. 9, a pair of pins 91 is located on each side of region of maximum bending of the bending area 10. The blocking element 60 is placed on the two pairs of pins 91. This arrangement of the pins 91 can also be seen in Fig. 10, however without the blocking element 60. Alternatively to this attachment of the blocking element 60 to the glove reinforcing element 1 with 4 pins 91, a smaller or higher number of pins 91 may be used.

**[0059]** The at least one blocking element 60 may be manufactured from the same material as the glove reinforcing element 1. Alternatively, the blocking element 60 is manufactured from a different material, preferably a harder one including metals or composite materials. In another embodiment, the blocking element 60 itself comprises more than one material. For example, the blocking element 60 may comprise a hard bottom layer to maximize reinforcement of the bending area 10 and a soft top layer, in order to minimize an impact to other objects contacted by the glove reinforcing element 1 during use.

**[0060]** In one embodiment, the blocking element 60 and the glove reinforcing element 1 are made from plastic material so that they can be permanently attached to each other by heating and pressing.

**[0061]** It is further preferred if the blocking element is detachably attached to the glove reinforcing element 1 so that the blocking element 60 can be exchanged. This

is useful when an adjustment of glove reinforcing element 1 to different purposes is required, for example an adjustment to a particular load or force exerted on the glove reinforcing element 1. To this end, blocking elements 60 with different mechanical properties may be used. Moreover, detachable blocking elements 60 enable the use of materials for blocking elements 60 with particular mechanical properties but which wear-out after some use so that they need replacement. For example, a goalkeeper may prefer to use harder blocking elements during training in order to improve protection of his fingers. On the other hand, during a game he may prefer softer blocking elements which provide a better feeling for the ball.

**[0062]** Fig. 11 is a perspective view of a blocking element 60 according to a preferred embodiment. As can be seen, the blocking element 60 comprises two parts 61 and 62. Moreover, the blocking element 60 comprises holes 121 corresponding to pins 91 of the glove reinforcing element 1. Fig. 11 also illustrates that the top surface of the blocking element 60 comprises a dome-shaped curvature.

**[0063]** Fig. 12 is the corresponding bottom view of the blocking element 60 of Fig. 11. As can be seen, the bottom side of the blocking element 60 also comprises a dome-shaped curvature. In a preferred embodiment, the bottom side of the blocking element 60 and the bending area 10 of the glove reinforcing element 1 have substantially the same dome-shaped curvature which facilitates the attachment of the two. As can be recognized in Fig. 12, the blocking elements 60 could preferably comprise indentations 132 on the bottom side of the blocking elements, whereby the indentations correspond to ribs 21 on the glove reinforcing element 1 (not shown in Fig. 12 but in Fig. 1) which extend into the bending area 10.

**[0064]** Fig. 12 also shows a recess 131 in the middle of the bottom side of the blocking element 60. As explained above, the bending area 10 obtains a different shape during bending, in particular along a centerline of the bending area 10. The recess 131 provides a space into which the bending area 10 can extend. Therefore, the recess 131 facilitates bending of the bending area 10. Moreover, it avoids stress on the blocking element 60 which may cause detachment of the blocking element 60.

**[0065]** The recess 131 is also illustrated in Fig. 13 which is a close-up perspective view of the bending area 10 of the glove reinforcing element 1. As can be seen, the recess 131 leaves a space between the bending area 10 and the bottom side of the blocking element 60. In this view, the glove reinforcing element 1 is not bent. As explained, the bending area 10 gradually extends into the recess 131 during bending. Fig. 13 illustrates different curvatures in the longitudinal direction and the transversal direction and on the top side and the bottom side of the blocking element 60.

**[0066]** As can also be recognized in Fig. 13, the pins 91 may extend out of the at least one blocking element 60. Once the at least one blocking element 60 has been

placed on a pin 91, the end of the pin 91 may be heated, for example by ultrasonic welding, and pressed downwards. Subsequently, the hot plastic material of the pins deforms and avoids a removal of the blocking element.

5 Preferably, the heated plastic material of the pin is squeezed into the recess provided by the conical expansion on the top of the holes 121 for the pins 91, which can be recognized in Fig. 11. This would then lead to a fixation of the at least one blocking element 60 on the  
10 glove reinforcing element 1, wherein the top surface of the blocking element 60 and the top surface of the pin 91 are preferably flush in the final state (not shown in Fig. 13).

**[0067]** The explained glove reinforcing element 1 is preferably arranged in the glove in a detachable manner. This generates a plurality of individual adaptation possibilities. For example, stiffer glove reinforcing elements can be exchanged against softer glove reinforcing elements if a goalkeeper prefers a lesser bending resistance. Besides an individual adaptation of the length,  
20 width variations are possible to comply with different finger thicknesses. Finally, a color adaptation for optical aspects is possible if the reinforcing elements are arranged in transparent "pockets" on the glove's back, e.g.  
25 corresponding to certain tricot colors. Moreover, the releasable arrangement in the glove enables the goalkeeper to replace damaged or insufficiently stiff glove reinforcing elements immediately, i.e. even during a game.

## 30 Claims

1. Glove reinforcing element (1), in particular for a goalkeeper glove, which allows a bending in gripping direction but avoids a hyperextension of the fingers and / or the hand, comprising
  - a. at least one bending area (10);
  - b. wherein the bending area (10) comprises a curvature having a shape which allows a bending of the glove reinforcing element (1) into at least a first direction and which blocks a bending of the glove reinforcing element (1) into at least a second direction, **characterized by**
  - c. at least one blocking element (60) arranged at the bending area (10).
2. Glove reinforcing element (1) according to claim 1, wherein the at least one bending area (10) has a dome-shaped curvature.
3. Glove reinforcing element (1) according to one of the preceding claims, wherein the bending area (10) is arranged in the region of the joints of a finger and / or the wrist when worn.
4. Glove reinforcing element (1) according to one of the preceding claims with a plurality of bending areas



- (10), which are assigned to a plurality of finger joints when worn.
5. Glove reinforcing element (1) according to one of the preceding claims, wherein an essentially rigid interconnection area 20 is arranged adjacent to the at least one bending area (10). 5
  6. Glove reinforcing element (1) according to claim 5, wherein the interconnection area (10) comprises a gutter-shaped curvature. 10
  7. Glove reinforcing element (1) according to claim 6, wherein the interconnection area (20) comprises at least one stiffening element (21) to avoid a deformation. 15
  8. Glove reinforcing element (1) according to one of the preceding claims with a sufficient length to extend starting from the backside of the hand up to essentially the end of a finger. 20
  9. Glove reinforcing element (1) according to one of the preceding claims having a length extending beyond the end of a finger. 25
  10. Glove reinforcing element (1) according to one of the preceding claims, wherein the glove reinforcing element (1) is made as a single piece. 30
  11. Glove reinforcing element (1) according to one of the preceding claims, wherein the glove reinforcing element (1) is made by multi-component injection molding at least two different plastic materials. 35
  12. Glove reinforcing element (1) according to one of the preceding claims, wherein the glove reinforcing element (1) is made from a suitable material and / or comprises a suitable coating to slide within a receptacle of a glove. 40
  13. Glove reinforcing element (1) according to one of the preceding claims further comprising a preferably releasably mounted additional weight (40). 45
  14. Glove reinforcing element (1) according to the preceding claim, wherein the additional weight (40) is arranged at the front end of the glove reinforcing element (1). 50
  15. Glove reinforcing element (1) according to one of the preceding claims, wherein the curvature of the at least one bending area (10) and / or the at least one interconnection area (20) extends starting from the backside of a finger laterally around the finger. 55
  16. Glove reinforcing element (1) according to one of the preceding claims, wherein the at least one bending area (10) and / or the at least one interconnection area (20) comprise at least one cut-out.
  17. Glove reinforcing element (1) according to any of the claims 1 to 9 and 11 to 16, wherein the at least one blocking element (60) is preferably detachably attached to the bending area (10).
  18. Glove reinforcing element (1) according to any of the preceding claims, wherein the at least one blocking element (60) is arranged on top of the at least one bending area (10).
  19. Glove reinforcing element (1) according to any of the preceding claims, wherein the at least one blocking element (60) comprises at least two parts (61, 62) arranged at the bending area (10) which blockingly contact each other when the bending area (10) blocks a bending of the glove reinforcing element (1).
  20. Glove reinforcing element (1) according to any of the preceding claims, wherein the top surface at least one blocking element (60) has a dome-shaped curvature.
  21. Glove reinforcing element (1) according any of the preceding claims, wherein the at least one blocking element (60) is manufactured from a different, preferably a harder material than a material of the glove reinforcing element (1).
  22. Glove reinforcing element (1) according to one of the preceding claims 1 to 9 and 11 to 21, wherein the blocking element (60) is a separate element and wherein the glove reinforcing element (1) comprises at least one pin (91) to which the blocking element (60) is attached.
  23. Glove reinforcing element (1) according to claim 22, wherein the blocking element (60) comprises a recess (131) at the bottom side.
  24. Glove reinforcing element (1) according to one of the claims 22 or 23, wherein at least two pins (91) are located on each side of the region of maximum bending of the bending area (10).
  25. Glove, in particular goalkeeper glove, comprising at least one glove reinforcing element (1) according to one of the preceding claims.
  26. Glove according to the preceding claim, wherein the glove further comprises an element (50) on the backside of the hand to which the at least one glove reinforcing element (1) is preferably releasably attached.
  27. Glove according to one of the preceding claims 25

or 26, wherein the element (50) for the backside of the hand is provided as a plate protecting the surface of the backside of the hand against injuries.

### Patentansprüche

1. Handschuhverstärkungselement (1), insbesondere für einen Torwarthandschuh, das ein Abwinkeln in Greifrichtung ermöglicht aber ein Überstrecken der Finger und / oder der Hand verhindert, mit
  - a. zumindest einem Biegebereich (10);
  - b. wobei der Biegebereich (10) eine Wölbung mit einer Formgebung aufweist, die ein Abbiegen des Handschuhverstärkungselements (1) in zumindest eine erste Richtung ermöglicht und ein Abbiegen des Handschuhverstärkungselements (1) in zumindest eine zweite Richtung verhindert, **gekennzeichnet durch**
  - c. zumindest ein Sperrelement (60), das in dem Biegebereich (10) angeordnet ist.
2. Handschuhverstärkungselement (1) nach Anspruch 1, wobei der zumindest eine Biegebereich (10) eine kuppelförmige Wölbung aufweist.
3. Handschuhverstärkungselement (1) nach einem der vorhergehenden Ansprüche, wobei der Biegebereich (10) beim Tragen im Bereich eines Fingergelenks und / oder des Handgelenks angeordnet ist.
4. Handschuhverstärkungselement (1) nach einem der vorhergehenden Ansprüche mit einer Mehrzahl von Biegebereichen (10), die beim Tragen einer Mehrzahl von Fingergelenken entsprechen.
5. Handschuhverstärkungselement (1) nach einem der vorhergehenden Ansprüche, wobei ein im Wesentlichen starrer Verbindungsbereich (20) benachbart zu dem zumindest einen Biegebereich (10) angeordnet ist.
6. Handschuhverstärkungselement (1) nach Anspruch 5, wobei der Verbindungsbereich (10) eine rinnenförmige Wölbung aufweist.
7. Handschuhverstärkungselement (1) nach Anspruch 6, wobei der Verbindungsbereich (20) zumindest ein Verstärkungselement (21) aufweist, um eine Verformung zu verhindern.
8. Handschuhverstärkungselement (1) nach einem der vorhergehenden Ansprüche mit einer ausreichenden Länge, um sich vom Handrücken ausgehend im Wesentlichen bis zum Ende eines Fingers zu erstrecken.
9. Handschuhverstärkungselement (1) nach einem der vorhergehenden Ansprüche mit einer Länge, um sich über das Ende eines Fingers hinaus zu erstrecken.
10. Handschuhverstärkungselement (1) nach einem der vorhergehenden Ansprüche, wobei das Handschuhverstärkungselement (1) als ein einstückiges Bauteil gefertigt ist.
11. Handschuhverstärkungselement (1) nach einem der vorhergehenden Ansprüche, wobei das Handschuhverstärkungselement (1) durch Mehrkomponentenspritzen aus zumindest zwei verschiedenen Kunststoffmaterialien gefertigt ist.
12. Handschuhverstärkungselement (1) nach einem der vorhergehenden Ansprüche, wobei das Handschuhverstärkungselement (1) aus einem geeigneten Material gefertigt ist und / oder eine geeignete Beschichtung aufweist, um innerhalb einer Aufnahme eines Handschuhs gleiten zu können.
13. Handschuhverstärkungselement (1), nach einem der vorhergehenden Ansprüche, ferner aufweisend Zusatzgewicht (40), das vorzugsweise lösbar befestigt ist.
14. Handschuhverstärkungselement (1) nach dem vorhergehenden Anspruch, wobei das Zusatzgewicht (40) am vorderen Ende des Handschuhverstärkungselements (1) angeordnet ist.
15. Handschuhverstärkungselement (1) nach einem der vorhergehenden Ansprüche, wobei die Wölbung des zumindest einen Biegebereichs (10) und / oder des zumindest einen Verbindungsbereichs (20) sich von der Rückseite eines Fingers beginnend seitlich um den Finger erstreckt.
16. Handschuhverstärkungselement (1) nach einem der vorhergehenden Ansprüche, wobei der zumindest eine Biegebereich (10) und / oder das zumindest eine Verbindungselement (20) zumindest eine Aussparung aufweist.
17. Handschuhverstärkungselement (1) nach einem der Ansprüche 1 bis 9 und 11 bis 16, wobei das zumindest eine Sperrelement (60) mit dem Biegebereich (10) verbunden, vorzugsweise lösbar verbunden ist.
18. Handschuhverstärkungselement (1) nach einem der vorhergehenden Ansprüche, wobei das zumindest eine Sperrelement (60) auf dem zumindest einen Biegebereich (10) angeordnet ist.
19. Handschuhverstärkungselement (1) nach einem der vorangehenden Ansprüche, wobei das zumindest

- eine Sperrelement (60) zumindest zwei Teile (61, 62) aufweist, die in dem Biegebereich (10) angeordnet sind, die sich sperrend berühren, wenn der Biegebereich (10) ein Biegen des Handschuhverstärkungselements (1) sperrt.
20. Handschuhverstärkungselement (1) nach einem der vorangehenden Ansprüche, wobei die obere Oberfläche des zumindest einen Sperrelements (60) eine kuppelförmige Wölbung aufweist.
21. Handschuhverstärkungselement (1) nach einem der vorangehenden Ansprüche, wobei das zumindest eine Sperrelement (60) aus einem anderen, vorzugsweise einem härteren Material als ein Material des Handschuhverstärkungselements (1) hergestellt wird.
22. Handschuhverstärkungselement (1) nach einem der vorangehenden Ansprüche 1 bis 9 und 11 bis 21, wobei das Sperrelement (60) ein separates Element ist und wobei das Handschuhverstärkungselement (1) wenigstens einen Zapfen (91) aufweist, an dem das Sperrelement (60) befestigt ist.
23. Handschuhverstärkungselement (1) nach Anspruch 22, wobei das Sperrelement (60) eine Vertiefung (131) auf der Unterseite aufweist.
24. Handschuhverstärkungselement (1) nach einem der Ansprüche 22 oder 23, wobei mindestens zwei Zapfen (91) auf jeder Seite des Bereichs der größten Biegung des Biegebereichs (10) angeordnet sind.
25. Handschuh, insbesondere Torwarthandschuh, mit zumindest einem Handschuhverstärkungselement (1) nach einem der vorhergehenden Ansprüche.
26. Handschuh nach einem dem vorhergehenden Anspruch, wobei das Handschuhverstärkungselement (1) weiterhin ein Element (50) auf der Rückseite der Hand aufweist, mit dem das Handschuhverstärkungselement (1) verbunden, vorzugsweise lösbar verbunden ist.
27. Handschuh nach einem der vorhergehenden Ansprüche 25 oder 26, wobei das Element (50) für die Rückseite der Hand als eine Platte bereitgestellt ist, die die Handrückenfläche gegen Verletzungen schützt.
- Revendications**
1. Élément de renfort de gant (1), en particulier pour un gant de gardien de but, qui autorise une flexion dans la direction d'agrippement mais évite une hyperextension des doigts et/ou de la main,
- comprenant :
- a. au moins une zone de flexion (10),
- b. la zone de flexion (10) comprenant une courbure ayant une forme qui permet une flexion de l'élément de renfort de gant (1) dans au moins une première direction et qui bloque une flexion de l'élément de renfort de gant (1) en au moins une seconde direction, **caractérisée par**
- c. au moins un élément de blocage (60) disposé à l'endroit de la zone de flexion (10).
2. Élément de renfort de gant (1) selon la revendication 1, dans lequel la au moins une zone de flexion (10) a une courbure en forme de dôme.
3. Élément de renfort de gant (1) selon l'une des revendications précédentes, dans lequel la zone de flexion (10) est disposée dans la région des articulations d'un doigt et/ou du poignet lorsqu'il est porté.
4. Élément de renfort de gant (1) selon l'une des revendications précédentes avec une pluralité de zones de flexion (10), qui sont affectées à une pluralité d'articulations de doigt lorsqu'il est porté.
5. Élément de renfort de gant (1) selon l'une des revendications précédentes, dans lequel une zone d'interconnexion essentiellement rigide (20) est disposée adjacente à la au moins une zone de flexion (10).
6. Élément de renfort de gant (1) selon la revendication 5, dans lequel la zone d'interconnexion (10) comprend une courbure en forme de gouttière.
7. Élément de renfort de gant (1) selon la revendication 6, dans lequel la zone d'interconnexion (20) comprend au moins un élément raidisseur (21) pour éviter une déformation.
8. Élément de renfort de gant (1) selon l'une des revendications précédentes avec une longueur suffisante pour s'étendre depuis le dos de la main jusqu'à essentiellement l'extrémité d'un doigt.
9. Élément de renfort de gant (1) selon l'une des revendications précédentes ayant une longueur s'étendant au-delà de l'extrémité d'un doigt.
10. Élément de renfort de gant (1) selon l'une des revendications précédentes, dans lequel l'élément de renfort de gant (1) est réalisé d'une seule pièce.
11. Élément de renfort de gant (1) selon l'une des revendications précédentes, dans lequel l'élément de renfort de gant (1) est réalisé par moulage par injection multi-composant d'au moins deux matières plas-

- tiques différentes.
- 12.** Élément de renfort de gant (1) selon l'une des revendications précédentes, dans lequel l'élément de renfort de gant (1) est réalisé à partir d'un matériau approprié et/ou comprend un revêtement approprié pour coulisser à l'intérieur d'un réceptacle d'un gant. 5
- 13.** Élément de renfort de gant (1) selon l'une des revendications précédente comprenant en outre une masse additionnelle montée de préférence de façon amovible (40). 10
- 14.** Élément de renfort de gant (1) selon l'une des revendications précédentes, dans lequel la masse additionnelle (40) est disposée à l'extrémité avant de l'élément de renfort de gant (1). 15
- 15.** Élément de renfort de gant (1) selon l'une des revendications précédentes, dans lequel la courbure de la au moins une zone de flexion (10) et/ou de la au moins une zone d'interconnexion (20) s'étend depuis le dos d'un doigt latéralement autour du doigt. 20
- 16.** Élément de renfort de gant (1) selon l'une des revendications précédentes, dans lequel la au moins une zone de flexion (10) et/ou la au moins une zone d'interconnexion (20) comprennent au moins une découpe. 25
- 17.** Élément de renfort de gant selon l'une des revendications 1 à 9 et 11 à 16, dans lequel le au moins un élément de blocage (60) est de préférence fixé de manière détachable à la zone de flexion (10). 30
- 18.** Élément de renfort de gant selon l'une des revendications précédentes, dans lequel le au moins un élément de blocage (60) est disposé au-dessus de la au moins une zone de flexion (10). 35
- 19.** Élément de renfort de gant (1) selon l'une des revendications précédentes, dans lequel le au moins un élément de blocage (60) comprend au moins deux pièces (61, 62) disposées à l'endroit de la zone de flexion (10) qui viennent en contact bloquant l'une avec l'autre lorsque la zone de flexion (10) bloque une flexion de l'élément de renfort de gant (1). 40
- 20.** Élément de renfort de gant (1) selon l'une des revendications précédentes, dans lequel la surface supérieure d'au moins un élément de blocage (60) présente une courbure en forme de dôme. 45
- 21.** Élément de renfort de gant (1) selon l'une des revendications précédentes, dans lequel le au moins un élément de blocage (60) est fabriqué à partir d'un matériau différent, de préférence plus dur, par rapport à un matériau de l'élément de renfort de gant (1). 50
- 22.** Élément de renfort de gant (1) selon l'une des revendications précédentes 1 à 9 et 11 à 21, dans lequel l'élément de blocage (60) est un élément séparé et dans lequel l'élément de renfort du gant (1) comprend au moins une broche (91) à laquelle est fixé l'élément de blocage (60). 55
- 23.** Élément de renfort de gant (1) selon l'une la revendication 22, dans lequel l'élément bloquant (60) comprend un évidement (131) du côté inférieur.
- 24.** Élément de renfort de gant (1) selon l'une des revendications 22 ou 23, dans lequel au moins deux broches (91) sont situées sur chaque côté de la région de flexion maximale de la zone de flexion (10).
- 25.** Gant, en particulier gant de gardien de but, comprenant au moins un élément de renfort de gant (1) selon l'une des revendications précédentes.
- 26.** Gant selon la revendication précédente, dans lequel le gant comprend en outre un élément (50) sur le dos de la main auquel est fixé de façon de préférence amovible le au moins un élément de renfort de gant (1).
- 27.** Gant selon l'une des revendications précédentes 25 ou 26, dans lequel l'élément (50) pour le dos de la main est prévu en tant que plaque protégeant la surface du dos de la main à l'encontre des blessures.

Fig. 1

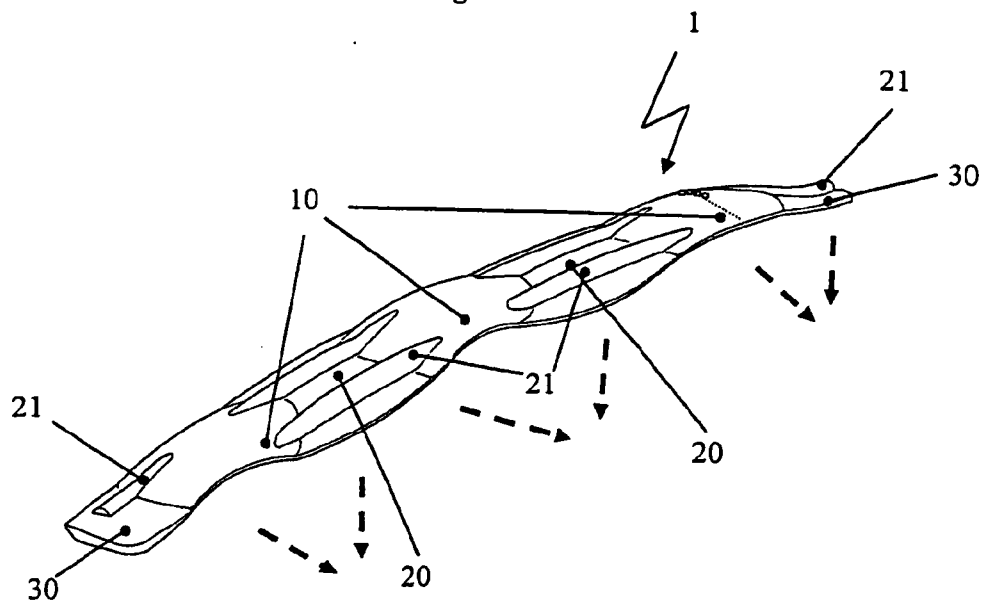

Fig. 2a

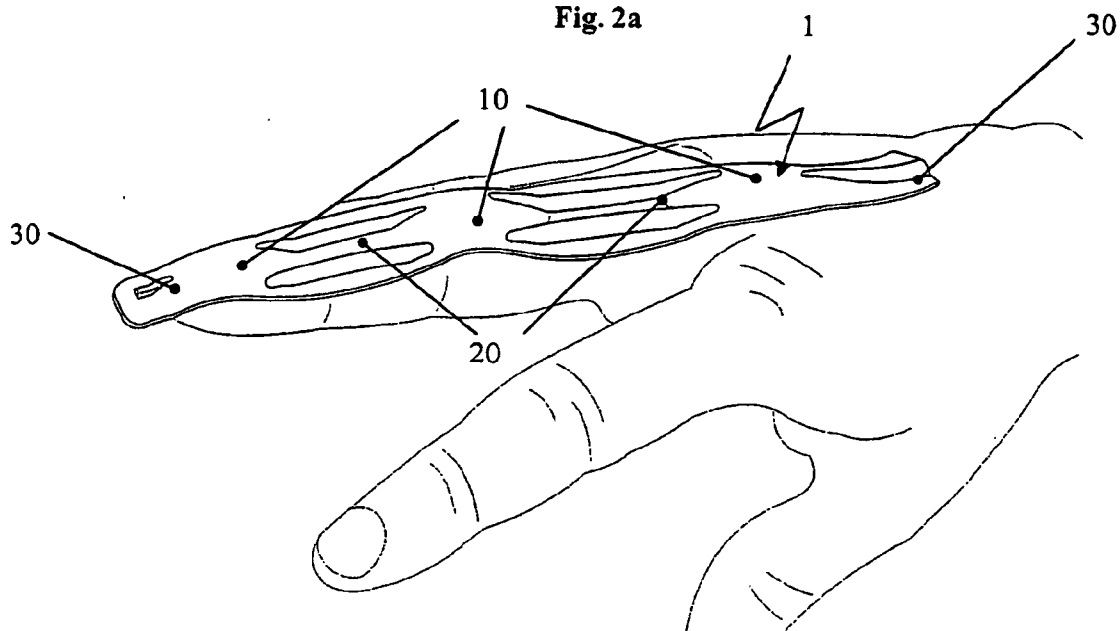

Fig. 2b

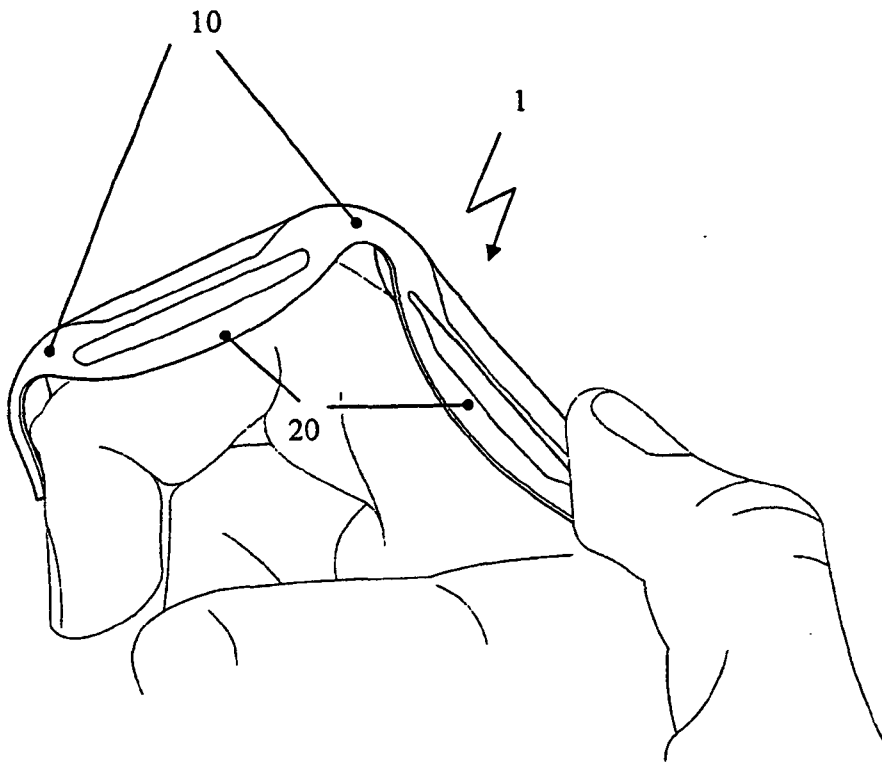

Fig. 3

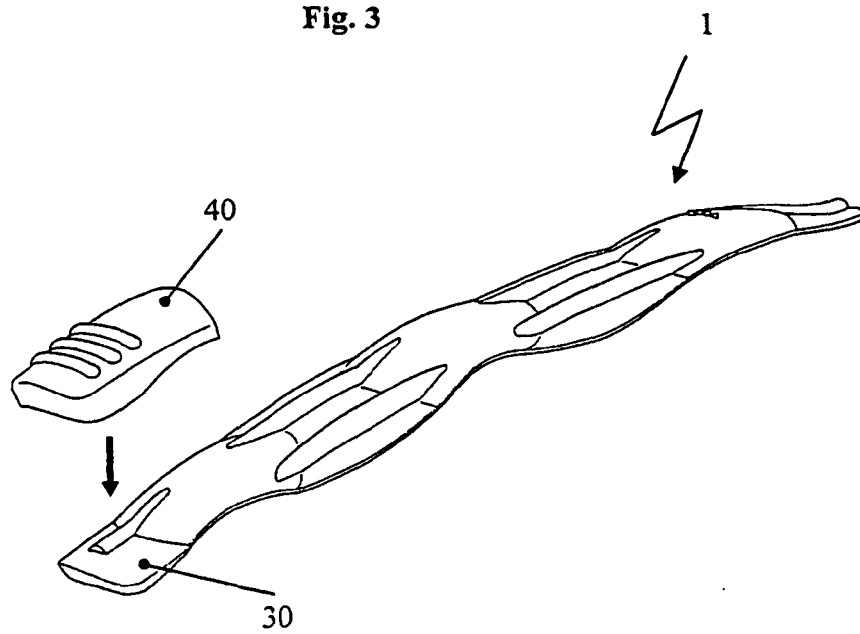

Fig. 4

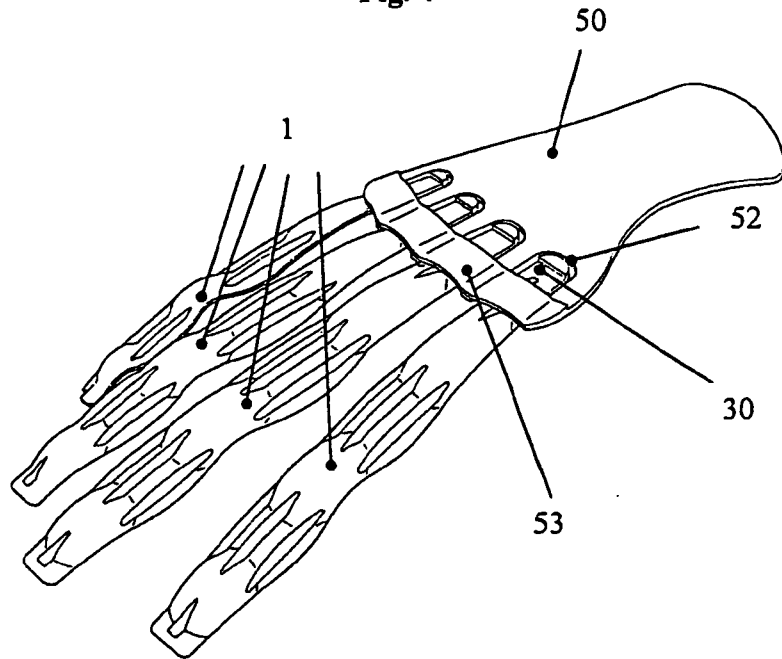
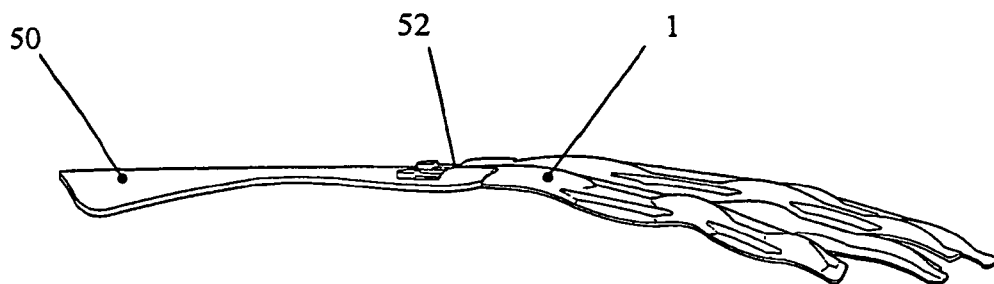

Fig. 5



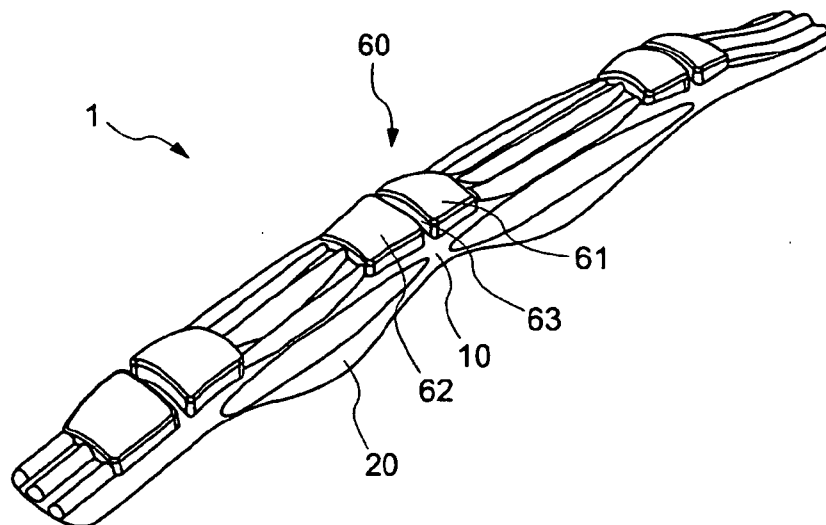

Fig. 6

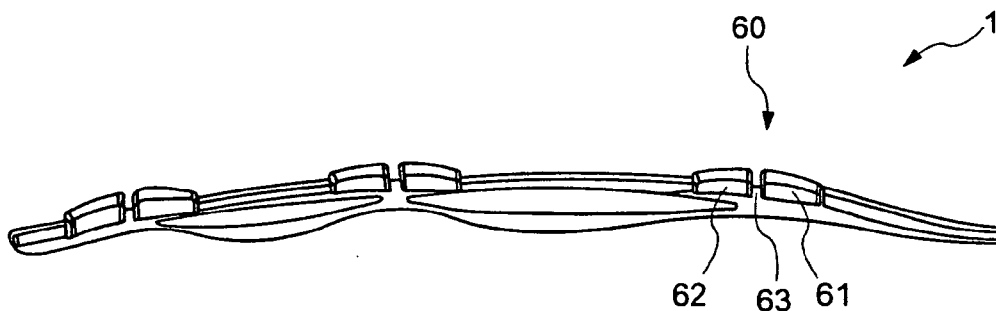

Fig. 7

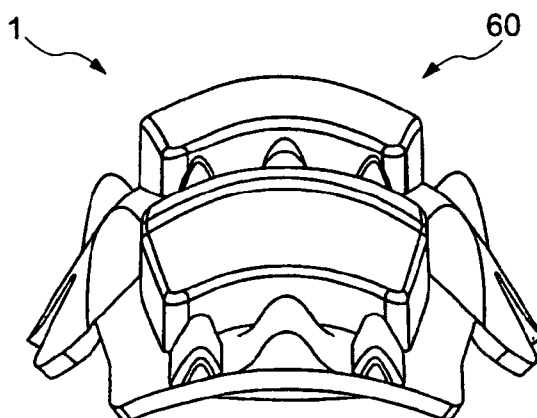

Fig. 8



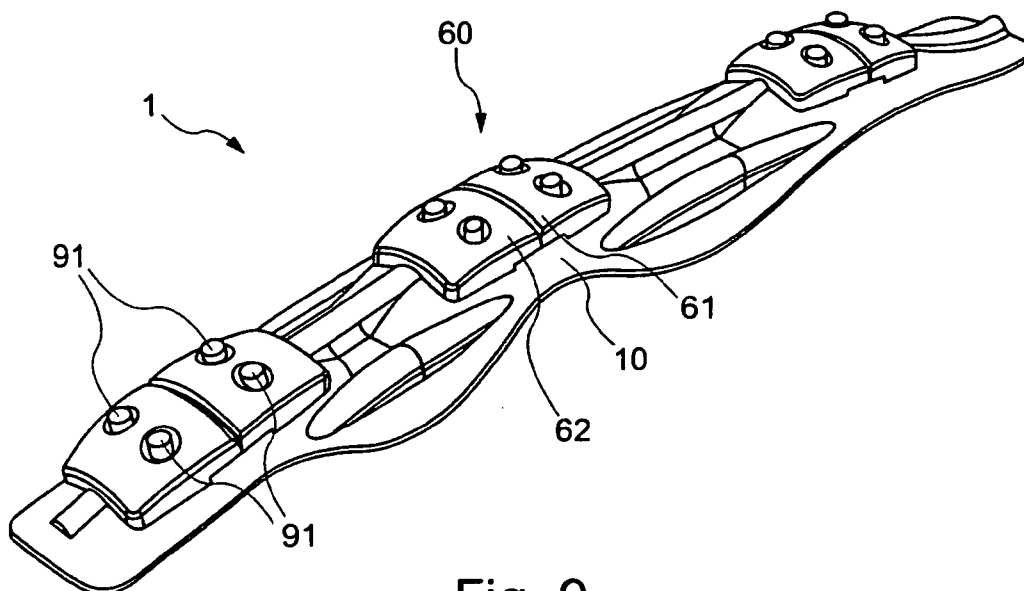

Fig. 9

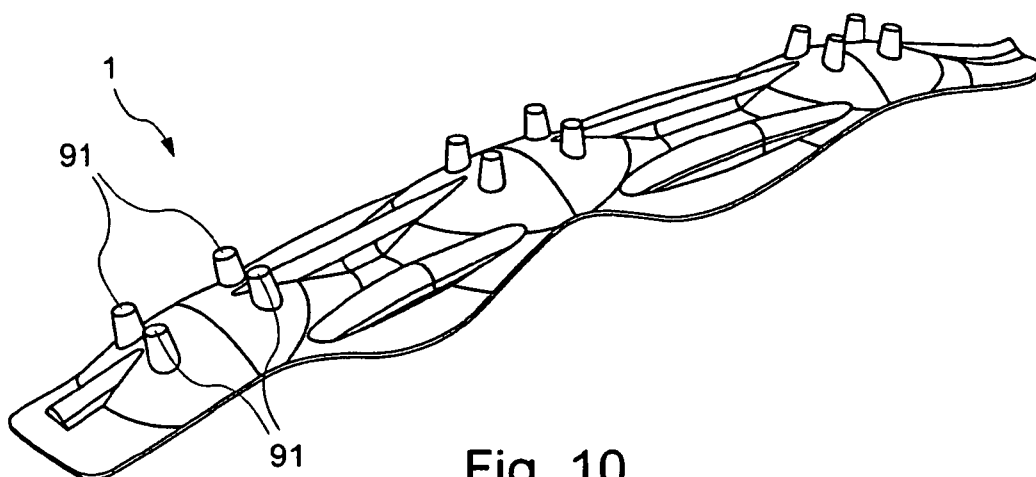

Fig. 10

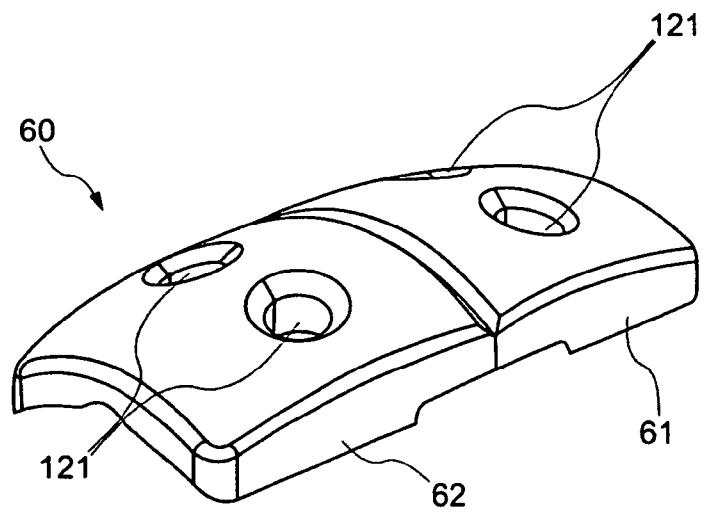

Fig. 11

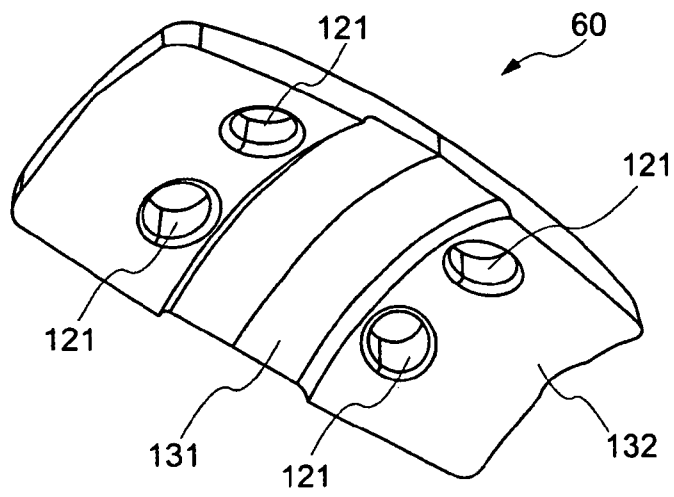

Fig. 12

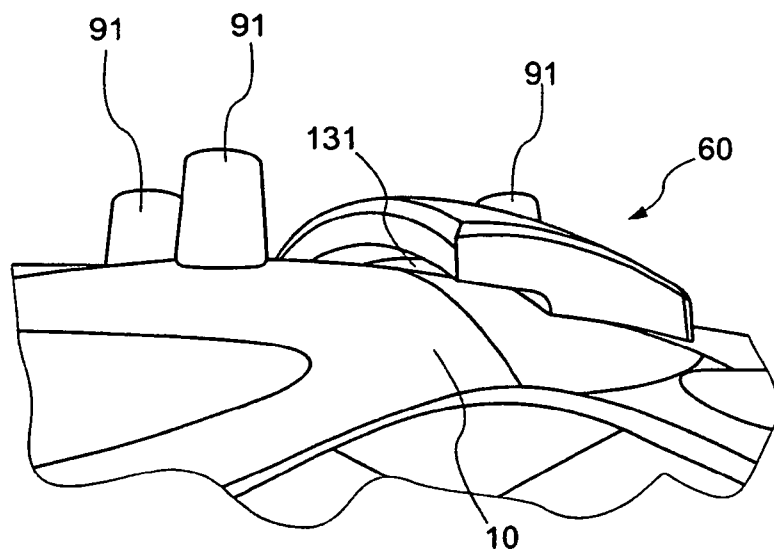

Fig. 13

**REFERENCES CITED IN THE DESCRIPTION**

*This list of references cited by the applicant is for the reader's convenience only. It does not form part of the European patent document. Even though great care has been taken in compiling the references, errors or omissions cannot be excluded and the EPO disclaims all liability in this regard.*

**Patent documents cited in the description**

- DE 3516545 C2 [0004] [0006] [0008]
- DE 20113431 U1 [0005] [0005]
- DE 10010404 A1 [0006]
- DE 2732463 [0011]
- DE 102005014470 B3 [0012]