

March 24, 1931.

A. MORISSE

1,797,668

BOTTOM FOR FOOTBALL SHOES

Filed May 23, 1929

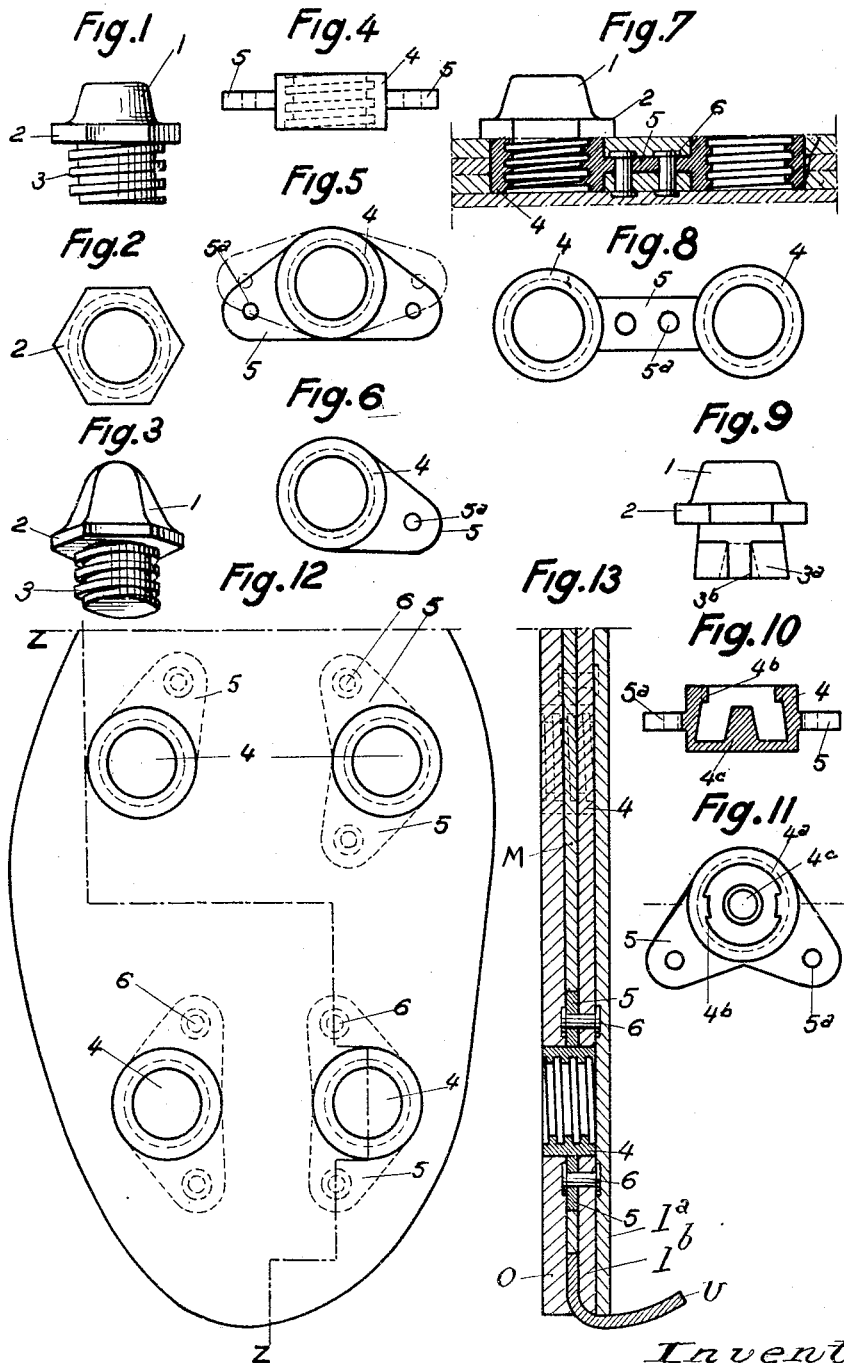

Inventor
A. Morisse
By Marks Clerk
Atty.

UNITED STATES PATENT OFFICE

ADRIEN MORISSE, OF ROUEN, FRANCE, ASSIGNOR OF ONE-HALF TO LEON TEIFEL, OF ROUEN, FRANCE

BOTTOM FOR FOOTBALL SHOES

Application filed May 23, 1929. Serial No. 365,442.

This invention relates to football or similar sport or athletic shoes or boots of the kind comprising a bottom embodying ground-engaging cleats or studs and plates securing the latter to the sole.

The primary object of the invention is to provide bottoms for football or like shoes wherein the ground-engaging cleats are firmly retained to the sole even when submitted to such high distorting stresses as are incident to football playing while being readily removable off the shoe by the wearer single-handed.

A further object of the invention is to provide bottoms for football or like shoes wherein the socket members securing the ground-engaging cleats to the sole do not impair the suppleness of the latter and do not cause any discomfort to the wearer i. e. football player.

Further objects and advantages of the invention will be apparent from the following description which, taken in connection with the accompanying drawing, discloses the preferred embodiments thereof.

In the drawing:

Figure 1 is an elevational view of the improved ground-engaging cleat according to the invention.

Figure 2 is a plan view of Figure 1.

Figure 3 is a similar view to Figure 1 showing a modification of the cleat.

Figure 4 is an elevational view of the socket member associated with the cleat and adapted to hold it to the sole.

Figure 5 is a plan view of Figure 4.

Figure 6 is a plan view of a simplified form of cleat-holding socket.

Figure 7 is a sectional view of a modified form of socket member riveted to the sole of the shoe and comprising two sockets one of which is fitted with a cleat.

Figure 8 is a plan view of the socket member shown in Figure 7.

Figure 9 is an elevational view of a modified form of cleat.

Figure 10 is a sectional view of the socket member matching the cleat shown in Figure 9.

Figure 11 is a plan view of Figure 10.

Figure 12 is a plan view of a football shoe

sole showing four cleat-holding socket members in position therein.

Figure 13 is a sectional view of Figure 12 on the irregular line Z—Z.

Like references designate like parts throughout the several views.

As illustrated, the cleat advantageously made of hard rubber or other similar resilient material comprises a head or stud 1, a polygonal or nut-like grip flange 2 and a tail 3 integral with one another.

The head 1 of the cleat is suitably sized and tapered; it may be in the shape of a frustum as shown in Figures 1 or 9 or in the shape of a pyramid with rounded apex, as shown in Figure 3, depending on the game to be played.

The tail 3 of the cleat is suitably sized and formed so as to be readily engageable into and disengageable from the holding socket member, as will be described. To that effect, the tail 3 may be screw-threaded (see Fig. 1 or 3) the threads being advantageously of square, rectangular or trapezoidal cross section for ensuring a better hold in the correspondingly screw-threaded socket. Alternatively the tail 3 may be formed with tongues 3a and grooves 3b (see Fig. 9) to engage corresponding grooves and tongues of a socket member such as the one shown in Fig. 10 after the fashion of a bayonet joint.

The grip flange 2 of the cleat formed integral therewith intermediate its head 1 and tail 3 is polygonally for example hexagonally shaped as a nut and may be of any suitable thickness. The purpose of this grip flange is to enable the wearer of the shoe i. e. the football player to readily grip the cleat single-handed and to disengage it from the socket or engage it thereinto in a very short time, for instance in the course of the game or between two consecutive game sets, in the event of the cleat being broken or becoming unsuitable e. g. due to the conditions of the playing ground.

The socket member matching the cleat as above-described is conveniently made of metal, for instance of aluminium alloy, and may present the several embodiments illustrated in Figures 4, 5, 6, 7, 8, 10 and 11. Whatever its embodiment may be, this socket

member comprises at least one socket 4 and one wing 5 formed integral therewith intermediate its ends, for example midway of its height. The socket 4 may be internally screwthreaded, for example square screwthreaded to match the screwthreaded on the tail 3 of the cleat, as shown in Fig. 4. Alternatively the socket 4 may have its inner wall formed with grooves 4a and tongues 4b as shown in Fig. 10 to match the corresponding tongues 3a and grooves 3b in a cleat as formed in Fig. 9. The socket 4 may be open at both ends as in Fig. 4 or closed at one end and provided with a shank 4c as in Fig. 10. The wing or wings 5 integrally formed with each socket 4 intermediate its ends are formed with holes 5a for the passage of rivets 6 or the like adapted to secure the socket member to the sole, as will be better described hereinafter. The socket 4 is advantageously circular and the peripheral shape of the wing or wings is advantageously rounded as shown and adapted to merge tangentially with the outer wall of the socket, particularly for facilitating the manufacture of such socket members.

In the majority of cases, it will be found that socket members having one socket 4 only and one or two wings 5 are preferable as they do not materially impair the suppleness or pliancy of the sole and thus cause a minimum uneasiness to the wearer. However in certain cases, socket members comprising twin-sockets 4 as shown in Figs. 7 and 8, may be preferred.

When the socket 4 comprises two wings 5 as shown in Figures 4, 5 and 11, said wings are advantageously symmetrical to each other with respect to the axis or centre of the socket. The shape of these wings 5 may however be any preferred one. In the majority of cases, a V-shaped arrangement of the wings such as the ones shown in full lines in Figure 5 or 11 will be preferred for the reasons hereafter stated. In such a case, the angle delineated by the V-arranged wings may be conveniently selected; this angle may be for example obtuse as in Figure 5 or acute as in Figure 11. However in other cases the wings 5 may be isosceles as shown by the dot and dash lines in Figure 5.

The arrangement of the socket members in the sole of the shoe will be readily understood from Figures 12 and 13 which disclose that their wing or wings 5 are located between the outsole O and the insole I, the latter being advantageously in two plies: an inner non-perforated ply I^a and an outer ply I^b perforated so as to accommodate the adjacent end of the sockets 4, the outsole O being also similarly perforated to accommodate the other end of said sockets, said end being substantially flush with the outer face of said outsole O whereby the socket members are, as it were, imbedded in the sole. The rivets

6 firmly securing the wings 5 to the sole engage through holes formed in the outer ply I^b of the insole opposite the holes 5a in said wings. An intermediate sole portion M, made for example of leather, is advantageously located between the outsole O and the outer ply I^b of the insole I for filling the intervening space corresponding to the thickness of the several wings 5 and maintaining the whole sole quite flat and even. Said intermediate portion M can for example terminate adjacent the edge of the upper U of the shoe.

The relative positions of the wings 5 of the socket members and of the sole are preferably as shown by Fig. 12 i. e. the angle formed by each pair of wings associated with a cleat-holding socket 4 being open towards the interior of the sole surface and each single wing snugly associated with a cleat-holding socket being similarly directed towards the interior of the sole surface whereby the sockets 4 proper can be positioned as near the edge of the sole as possible without their wings stiffening said edge to any appreciable extent which gives the wearer more comfort. At the same time, this disposition of the wings permits to reduce the number of socket members to the minimum that is compatible with the proper engagement of the ground by the cleats since the perimetral area delineated by the respective centres of the sockets 4 is correspondingly enhanced.

The number of socket members associated with the sole can of course be varied to suit particular requirements, the number of cleats being correspondingly increased. In this respect, it will be appreciated that Figure 12 is a mere illustration of the invention and that the number of sockets and cleats may be larger or smaller than four and their arrangement may vary, for example may be staggered.

It will be understood that by the particular construction and arrangement of the socket members and ground-engaging cleats as above-described, the objects of the invention are attained inasmuch as each cleat is firmly and removably retained in its holding socket while the sole is not appreciably stiffened by the socket members and the cleats being made of hard rubber form a springy and yet firm cushion between the sole and the ground. Moreover as the wings 5 are imprisoned between the outsole and insole without being flush with the inner end of the sockets 4 the distorting stresses due to the contact of the cleats and the ground are substantially taken up whereby the durability of the sole is increased.

Numerous minor constructional details might of course be varied without departing from the spirit of the invention.

What I claim is:—

1. Bottoms for football or like shoes com-

70

75

80

85

90

95

100

105

110

115

120

125

130

prising, in combination, a perforated outsole, a two-ply insole having its outer ply correspondingly perforated, metal socket members each formed of an innerly screw-threaded socket snugly housed in a pair of registering perforations in the soles and flush with the outsole and a pair of symmetrical arcuate wings integrally formed with the socket intermediate its ends, each pair of said wings being arranged in V shape off the periphery of the soles and located between the outsole and the outer ply of the insole and riveted to the latter, and resilient ground-engaging cleats each formed of a tapering head, a screw-threaded tail removably engageable into the socket and an intermediate polygonal grip flange.

2. Bottoms for football or like shoes comprising, in combination, a perforated outsole, a two-ply insole having its outer ply correspondingly perforated, metal socket members each formed of a socket snugly housed in a pair of registering perforations in the soles and a wing portion integrally formed with the socket intermediate its ends, each wing portion being directed off the periphery of the soles and located between the outsole and the outer ply of the insole and riveted to the latter, an intermediate sole portion substantially corresponding to the thickness of the wing portion and located in the empty space between the outsole and the outer ply of the insole, and resilient ground-engaging cleats each formed of a tapering head, a screw-threaded tail engageable into the socket and an intermediate polygonal grip flange.

3. Bottoms for football or like shoes comprising, in combination, an outsole formed with a number of spaced perforations, a two-ply insole having its outer ply correspondingly perforated, socket members each formed of a socket snugly housed in a pair of registering perforations in the soles and a pair of symmetrical arcuate wings integrally formed with the socket intermediate its ends, each pair of said wings being arranged to form a V having its open side off the periphery of the soles and being located between the outsole and the outer ply of the insole and riveted to the latter, an intermediate sole portion substantially corresponding to the thickness of the wings and filling the empty space between the outsole and the outer ply of the insole, and resilient ground-engaging cleats each formed of a tapering head, an intermediate polygonal grip flange and a tail formed so as to removably and firmly engage the socket.

4. Bottoms for football or like shoes comprising, in combination, an outsole formed with a number of spaced perforations, a two-ply insole having its outer ply correspondingly perforated, socket members each formed of an innerly square screw-threaded

socket snugly housed in a pair of registering perforations in the soles and a pair of symmetrical arcuate wings integrally formed with the socket intermediate its ends, each pair of said wings being arranged to form a V having its open side off the periphery of the soles and being located between the outsole and the outer ply of the insole and riveted to the latter, an intermediate pliant sole portion substantially as thick as the wings and filling the empty space between the outsole and insole, and resilient ground-engaging cleats each formed of a tapering head, a hand operable polygonal grip flange intermediate its ends and a tail formed with screw-threads to removably and firmly engage the socket.

In testimony whereof I affix my signature.

ADRIEN MORISSE.